



# 6236-C/6236A-C

## SOFT SERVE FREEZER

Single Flavor, Countertop, Digital Control  
A: Pump Feed Model



### Powerful and Versatile

Single flavor high capacity countertop model for ice cream, frozen yogurt and much more

#### Fast Freeze Down

Patented high efficiency heat exchanger allows fast freeze down with low energy consumption

#### Digital Control and Display

Microprocessor control provides access to system settings and additional functions. Digital interface displays critical info as system status, temperatures, dispense count, errors, etc.

#### Auto Programming

Allows automatic switching of operation modes based on preset schedules

#### Standby

Maintains product temperature in both mix hopper and freezing cylinder below 4.4°C (40°F) overnight

#### Hopper Agitator

Maintain product consistency and prevent product separation

Ideal for high capacity outlets to serve ice cream, frozen yogurt, gelato or sorbet. Fully loaded with all standard options. Small footprint saves counter space.

#### Soft System Start

Slow motor start reduces equipment noise and stress on drive train

#### Direct Drive Transmission

Eliminates consumable moving parts and increases transmission efficiency

#### Defrost for Cleaning

Increases efficiency during cleaning by heating frozen product in cylinder

#### Quick Freeze

Turn on freeze immediately to freeze down to serving viscosity when quick service is required after long idle period

#### Self-closing Valve with Speed Control

Automatically prevents product overflow after dispense; Provides flexibility in dispense rate control

#### Safety Protections

- Low temperature and motor overload shutoffs to protect in the event of cylinder freeze up
- High pressure switch to prevent compressor overheating



# 6236-C / 6236A-C

# SOFT SERVE FREEZER

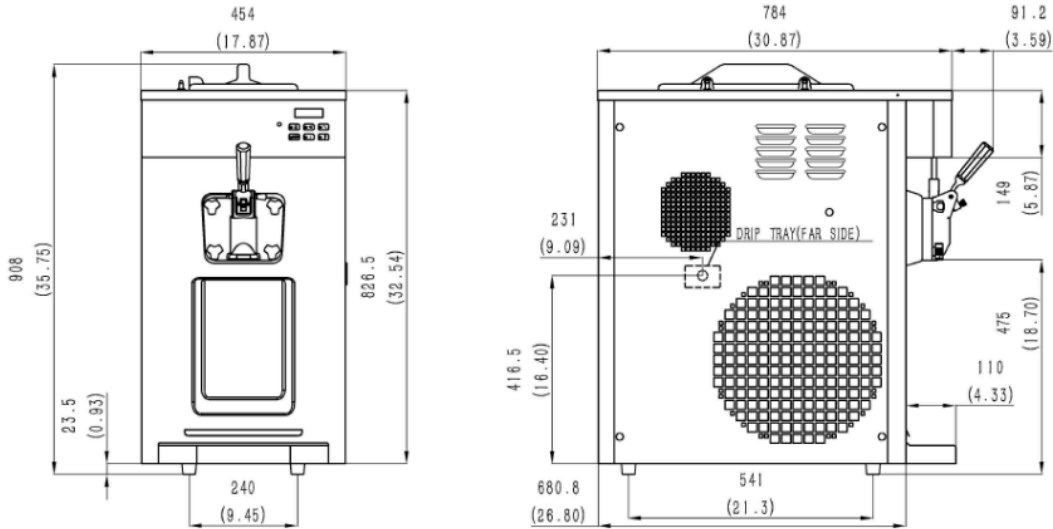

## SPECIFICATIONS

Flavors	1
Freezing Cylinders	1 x 3.2L / 3.4qt
Mix Hoppers	1 x 12L (8L for A)
Output Capacity (80 grams)	400 serves/hr
Clearance Requirements	152mm/6" on left

Weight	Kg/lb (Gravity)	Kg/lb (Pump)
Net	139 / 309	144 / 320
Shipping	152 / 338	157 / 349
Volume	0.47 CBM / 16.62 CBF	

Dimensions	Net (mm/in)	Shipping (mm/in)
Width	454 / 17.9	500 / 19.7
Depth	681 / 26.8	870 / 34.3
Height	908 / 35.8	1080 / 42.5

Electrical	MFS	MCA	Power(kW)
220-240/50/1	20	13	2.4
208-230/60/1	20	15	2.7

## FEATURES

Control System	Single, Digital
Refrigerated Hopper	<input checked="" type="checkbox"/>
Hopper Agitator	<input checked="" type="checkbox"/>
Temperature Display	<input checked="" type="checkbox"/>
Standby Mode	<input checked="" type="checkbox"/>
Auto Closing Dispensing Valve	<input checked="" type="checkbox"/>
Dispensing Speed Control	<input checked="" type="checkbox"/>
Low Mix Indicator Light & Alarm	<input checked="" type="checkbox"/>
Low Temperature Protection	<input checked="" type="checkbox"/>
Motor Overload Protection	<input checked="" type="checkbox"/>
High Pressure Protection	<input checked="" type="checkbox"/>
Defrost & Quick Freeze	<input checked="" type="checkbox"/>
Soft Start	<input checked="" type="checkbox"/>
Direct Drive Pump (A only)	<input checked="" type="checkbox"/>

## AVAILABLE OPTIONS

Water Cooled	<input checked="" type="checkbox"/>
Top Air Discharge Chute	<input checked="" type="checkbox"/>
Cart (Trolley)	<input checked="" type="checkbox"/>

• Above specifications are subject to change without notice