



6235-C/6235A-C

SOFT SERVE FREEZER

Two Flavor, Countertop, Digital Control
A: Pump Feed Model

Powerful and Versatile

Two flavor medium capacity countertop model for ice cream, frozen yogurt and much more

Fast Freeze Down

Patented high efficiency heat exchanger allows fast freeze down with low energy consumption

Digital Control and Display

Microprocessor control provides access to system settings and additional functions. Digital interface displays critical info as system status, temperatures, dispense count, errors, etc.

Auto Programming

Allows automatic switching of operation modes based on preset schedules

Standby

Maintains product temperature in both mix hopper and freezing cylinder below 4.4°C (40°F) overnight

Hopper Agitator

Maintain product consistency and prevent product separation

Ideal for medium capacity outlets to serve ice cream, frozen yogurt, gelato or sorbet. Fully loaded with all standard options.



Soft System Start

Slow motor start reduces equipment noise and stress on drive train

Direct Drive Transmission

Eliminates consumable moving parts and increases transmission efficiency

Defrost for Cleaning

Increases efficiency during cleaning by heating frozen product in cylinder

Quick Freeze

Turn on freeze immediately to freeze down to serving viscosity when quick service is required after long idle period

Self-closing Valve with Speed Control

Automatically prevents product overflow after dispense; Provides flexibility in dispense rate control

Safety Protections

- Low temperature and motor overload shutoffs to protect in the event of cylinder freeze up
- High pressure switch to prevent compressor overheating



6235-C / 6235A-C

SOFT SERVE FREEZER

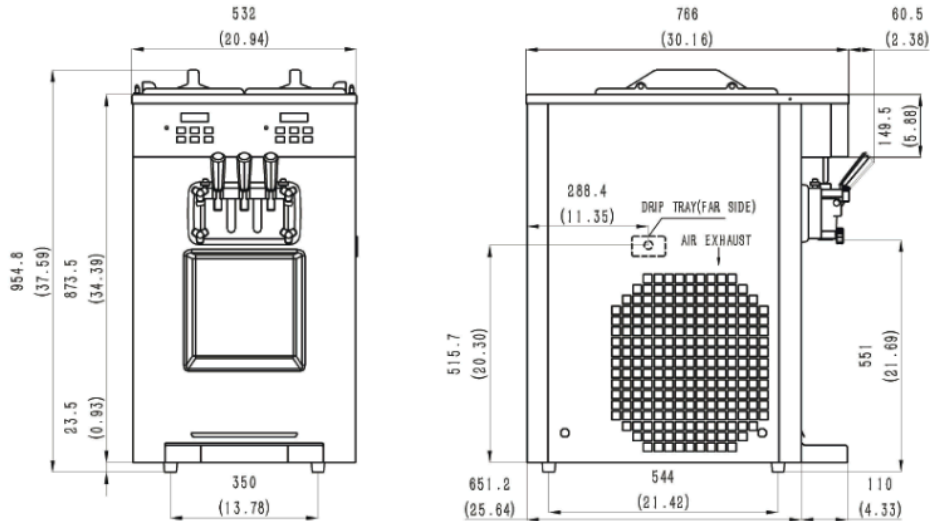

SPECIFICATIONS

Flavors	2 + Twist
Freezing Cylinders	2 x 1.7L / 1.8qt
Mix Hoppers	2 x 12L (8L for A)
Output Capacity (80 grams)	450 serves/hr
Clearance Requirements	152mm/6" on left

Weight	Kg/lb (Gravity)	Kg/lb (Pump)
Net	186 / 413	196 / 436
Shipping	200 / 445	210 / 467
Volume	0.62 CBM / 21.76 CBF	

Dimensions	Net (mm/in)	Shipping (mm/in)
Width	532 / 20.9	620 / 24.4
Depth	651 / 25.6	930 / 36.6
Height	955 / 37.6	1070 / 42.1

Electrical	MFS	MCA	Power(kW)
220-240/50/1	20	16	3.2
208-230/60/1	20	18	3.5

FEATURES

Control Systems	Two, Digital
Refrigerated Hoppers	✓
Hopper Agitators	✓
Temperature Displays	✓
Standby Mode	✓
Auto Closing Dispensing Valves	✓
Dispensing Speed Control	✓
Low Mix Indicator Light & Alarm	✓
Low Temperature Protection	✓
Motor Overload Protection	✓
High Pressure Protection	✓
Defrost & Quick Freeze	✓
Soft Start	✓
Direct Drive Pump (A only)	✓

AVAILABLE OPTIONS

Water Cooled	✓
Top Air Discharge Chute	✓
Cart (Trolley)	✓

• Above specifications are subject to change without notice