



# 6690-C

## FROZEN BEVERAGE FREEZER

Single flavor, Countertop, Gravity feed

### Powerful & Versatile

High capacity single flavor counter model for frozen beverage and milkshakes

#### Fast Freeze Down

Patented high efficiency heat exchanger allows fast freeze down with low energy consumption

#### Simple Control, Easy Operation

Simple and intuitive control system makes operation and viscosity adjustment easy, swift and more precise

#### Low Mix Indicator

Light turns "ON" at low mix to alert operator to add mix

#### See-through Dispensing Door

Clear dispensing door design makes product more attractive and serves as great marketing tool

#### Standby & Indicator

Maintains product temperature in both mix hopper and freezing cylinder below 4.4°C (40°F) overnight; Indicator lights up during Standby

Higher capacity solution with greater flexibility to serve larger crowds alcoholic & non-alcoholic frozen drinks including milkshakes



#### Hopper Agitator

Maintain product consistency and prevent product separation

#### Self-closing Dispensing Valve

Automatically prevents product overflow after dispense

#### Safety Protections

- High pressure switch to prevent compressor overheating
- Thermal overload to protect from motor overheating

#### Light Box (Optional)

- Illuminates flavor cards to attract more business
- Changes color to indicate Low Mix and Standby

#### One-hand Operated Spinner (Optional)

- Adds ability to blend and offer more varieties of treats
- Allows for multi-tasking one-hand operation that helps increase productivity and reduce serving time



# 6690-C

## FROZEN BEVERAGE FREEZER

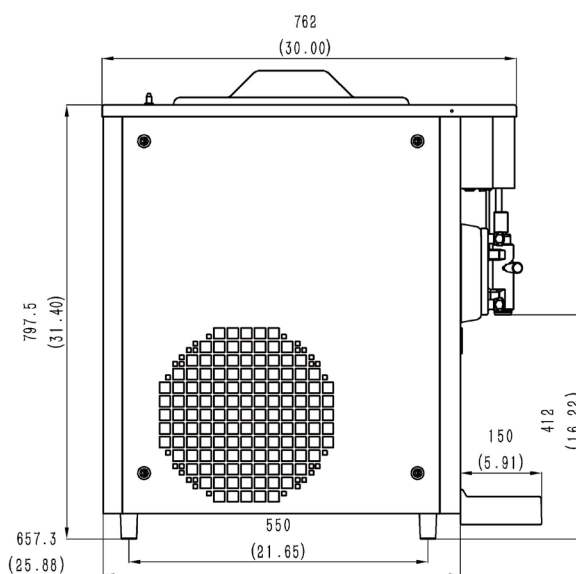
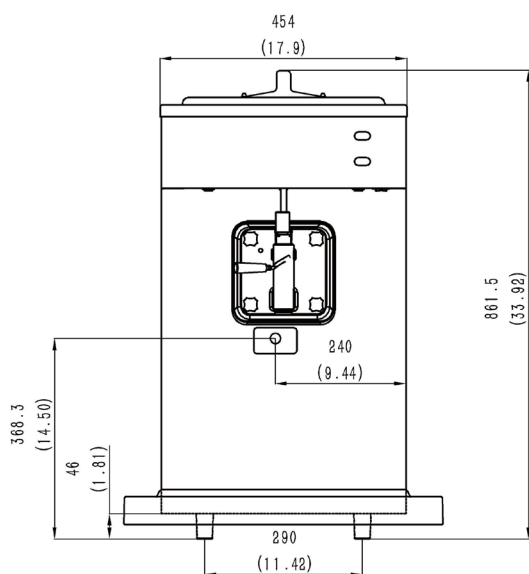

### SPECIFICATIONS

Flavors	1
Freezing Cylinders	1x 6.9L / 7.3qt
Mix Hoppers	1x 20L / 21.2qt
Output Capacity (250ml)	240 serves/hr
Clearance Requirements	152mm/6" on left

### Weight

### Kg/lb

Net	138 / 304
Shipping	151 / 333
Volume	0.44 CBM / 15.48 CBF

### Dimensions

### Net (mm/in)

### Shipping (mm/in)

Width	454 / 17.9	520 / 20.5
Depth	657 / 25.9	860 / 33.9
Height	862 / 33.9	980 / 38.6

### Electrical

### Power (kW)

### Total Amps (A)

### Fuse (A)

220-240/50/1	2.4	12	20
208-230/60/1	2.6	13	20

### FEATURES

Control System	One, Mechanical
Refrigerated Hopper	<input checked="" type="checkbox"/>
Hopper Agitator	<input checked="" type="checkbox"/>
Auto Closing Dispensing Valve	<input checked="" type="checkbox"/>
Low Mix Indicator Light	<input checked="" type="checkbox"/>
Low Mix Indicator Alarm	<input checked="" type="checkbox"/>
Standby Mode	<input checked="" type="checkbox"/>
Standby Indicator Light	<input checked="" type="checkbox"/>
High Pressure Protection	<input checked="" type="checkbox"/>
Thermal Overload Protection	<input checked="" type="checkbox"/>

### AVAILABLE OPTIONS

Top Air Discharge Chute	<input checked="" type="checkbox"/>
Spinner	<input checked="" type="checkbox"/>
Light Box	<input checked="" type="checkbox"/>

• Above specifications are subject to change without notice