



Item: _____

Quantity: _____

Project: _____

Dump Station

Royal Series

Models: RFT-DS



RFT-DS shown with optional heat lamp and optional casters

Standard Features

- All stainless steel front and sides
- 6" high adjustable heavy duty legs

Options and Accessories

- 5" swivel casters
- Heat lamp

2 YEAR LIMITED, PARTS AND LABOR WARRANTY



Dump Station

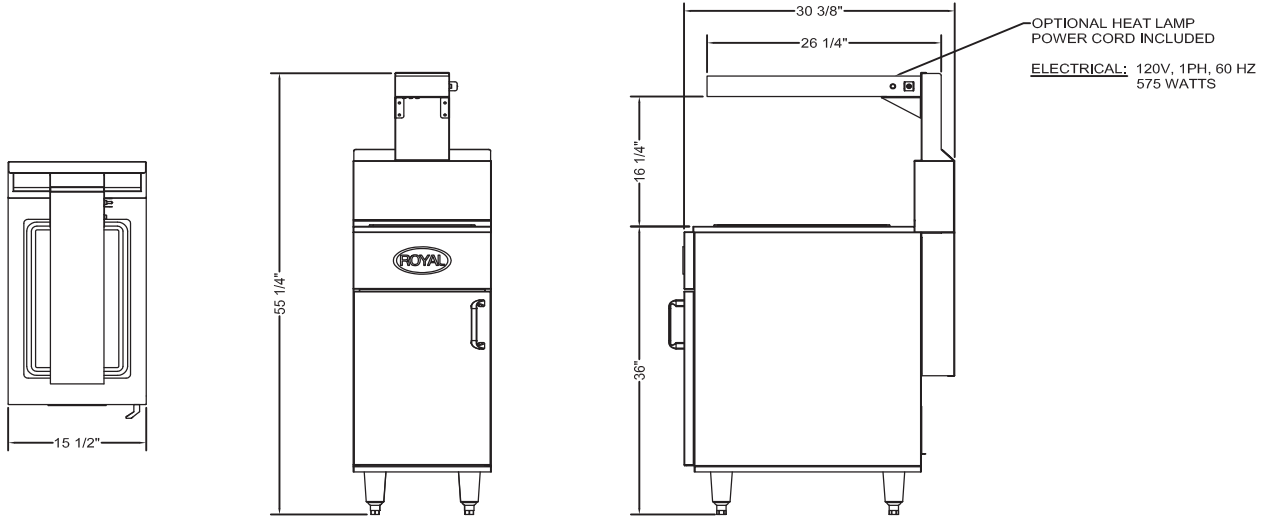

Model Number	Cooking Area	Number of Burners	Total BTU	Ship Weight
RFT-DS				130 lbs.

Electrical:

For optional heat lamp on RFT-DS:

120V, 60Hz, 1 phase, 6 amps

Due to continuing product development to ensure best possible performance, these specifications are subject to change without prior notification.

Royal Range of California, Inc.
 3245 Corridor Dr. • Eastvale, CA 91752 • (800) 769-2414 • (951) 360-1600
 Fax: (951) 360-7500 • www.royalranges.com • sales@royalranges.com