

Dell PowerEdge XR8000r

Installation and Service Manual

Notes, cautions, and warnings

 **NOTE:** A NOTE indicates important information that helps you make better use of your product.

 **CAUTION:** A CAUTION indicates either potential damage to hardware or loss of data and tells you how to avoid the problem.

 **WARNING:** A WARNING indicates a potential for property damage, personal injury, or death.

Chapter 1: About this document	5
Chapter 2: Dell PowerEdge XR8000r system configurations and features	6
System configurations - front view for PowerEdge XR8000r.....	6
System configurations - rear view for PowerEdge XR8000r.....	7
Power supply unit indicator codes.....	7
Locating the Express Service Code and Service Tag.....	9
System information label.....	10
Rail sizing and rack compatibility matrix.....	10
Chapter 3: Technical specifications	12
Chassis dimensions	12
System weight.....	13
PSU specifications.....	13
Power module assembly.....	14
PowerEdge XR sleds ports and connectors.....	15
PowerEdge XR8610t.....	15
PowerEdge XR8620t.....	16
Environmental specifications.....	16
Environmental Considerations.....	16
Chapter 4: Installing and removing system components	18
Safety instructions.....	18
Before working inside your system	18
After working inside your system.....	18
Recommended tools.....	19
XR8000r chassis.....	19
Removing a sled blank.....	19
Installing a sled blank.....	20
Removing a sled.....	20
Installing a sled	21
Rear cover.....	22
Removing the rear cover.....	22
Installing the rear cover.....	23
Power module assembly.....	24
Removing power module assembly.....	24
Installing the power module assembly.....	25
Power supply unit.....	26
Removing a power supply unit blank.....	26
Removing a power supply unit.....	27
Installing a power supply unit.....	28
Installing a power supply unit blank.....	29
Chapter 5: Getting help	31

Recycling or End-of-Life service information.....	31
Contacting Dell Technologies.....	31
Accessing system information by using QRL.....	31
Quick Resource Locator for PowerEdge XR8000r system.....	32
Receiving automated support with Secure Connect Gateway (SCG).....	32
Chapter 6: Documentation resources.....	33

About this document

This document provides an overview about the system, information about installing and replacing components, diagnostic tools, and guidelines to be followed while installing certain components.

Dell PowerEdge XR8000r system configurations and features

The PowerEdge XR8000r system is a 2U rackmount chassis that supports:

- Up to two XR8620t 2U single-width compute sleds
- Up to two redundant AC or DC power supply units

Topics:

- System configurations - front view for PowerEdge XR8000r
- System configurations - rear view for PowerEdge XR8000r
- Power supply unit indicator codes
- Locating the Express Service Code and Service Tag
- System information label
- Rail sizing and rack compatibility matrix

System configurations - front view for PowerEdge XR8000r

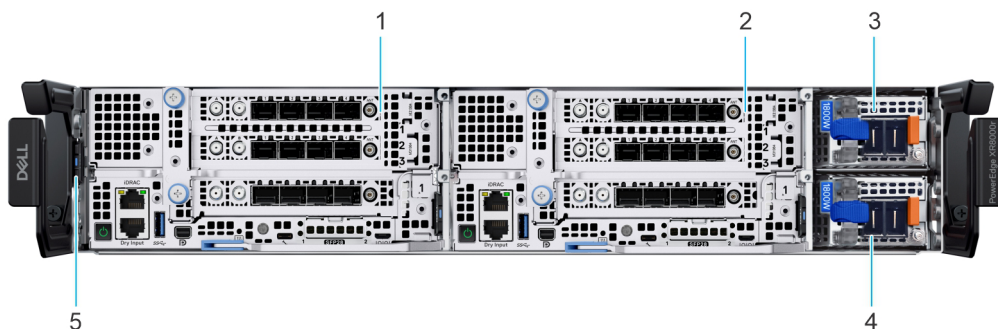



Figure 1. Front view of chassis with 2U sleds

Table 1. Features available on the front of the system

Item	Ports, panels, and slots	Icon	Description
1	XR8620t 2U sled	N/A	XR8620t server for computing (Sled 1)
2	XR8620t 2U sled	N/A	XR8620t server for computing (Sled 2)
3	Power supply 1		Indicates PSU 1 (primary PSU)
4	Power supply 2		Indicates PSU 2 (secondary PSU)
5	Information tag	N/A	Information tag which contains Service tag, Express service code and QRL information of the chassis

System configurations - rear view for PowerEdge XR8000r

Rear view of the system

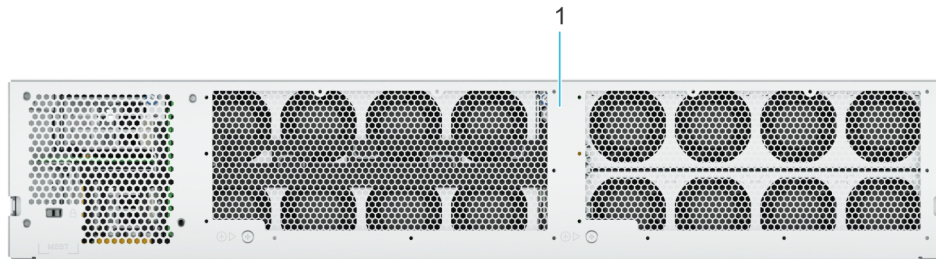

Table 2. Rear view of the system

Item	Ports, panels, or slots	Icon	Description
1	Rear cover	N/A	Removable rear cover.

Power supply unit indicator codes

AC and DC power supply units (PSUs) have an illuminated translucent handle that serves as an indicator. The indicator shows if power is present or if a power fault has occurred.

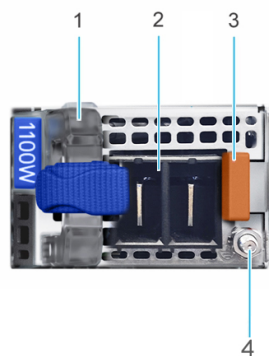

Figure 2. DC PSU status indicator

1. DC PSU handle
2. Socket
3. Release latch
4. Grounding stud

NOTE: For information about DC PSU cabling instructions, see the Cabling instructions for - (48 - 60) V DC power supply Tech sheet that is shipped with your DC PSU or go to <https://www.dell.com/poweredgemanuals> > XR Servers > PowerEdge XR8000r > Select This Product > Documentation > Manuals and Documents > Cabling instructions for - 48 - 60 V DC power supply.

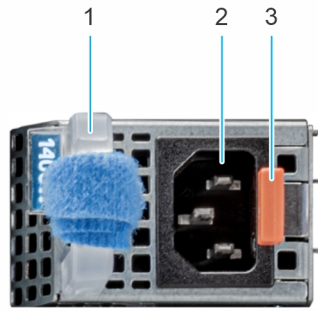

Figure 3. AC PSU status indicator

1. AC PSU handle
2. Socket
3. Release latch

Table 3. DC and AC PSU status indicator codes

Power indicator codes	Condition
Green	Indicates that a valid power source is connected to the PSU and the PSU is operational.
Blinking amber	Indicates an issue with the PSU.
Not powered on	Indicates that the power is not connected to the PSU.
Blinking green	Indicates that the firmware of the PSU is being updated. CAUTION: Do not disconnect the power cord or unplug the PSU when updating firmware. If firmware update is interrupted, the PSUs will not function.
Blinking greens and powers off	When hot-plugging a PSU, it blinks green five times at a rate of 4 Hz and powers off. This indicates a PSU mismatch due to efficiency, feature set, health status, or supported voltage. CAUTION: If two PSUs are installed, both the PSUs must have the same type of label; for example, Extended Power Performance (EPP) label. Mixing PSUs from previous generations of PowerEdge servers is not supported, even if the PSUs have the same power rating. This results in a PSU mismatch condition or failure to power on the system. CAUTION: If two PSUs are used, they must be of the same type and have the same maximum output power. CAUTION: When correcting a PSU mismatch, replace the PSU with the blinking indicator. Swapping the PSU to make a matched pair can result in an error condition and an unexpected system shutdown. To change from a high output configuration to a low output configuration or vice versa, you must power off the system. CAUTION: AC PSUs support both 240 V and 120 V input voltages except for Titanium PSUs, which support only 240 V. When two identical PSUs receive different input voltages, they can output different wattages, and trigger a mismatch.

Locating the Express Service Code and Service Tag

The unique Express Service Code and Service Tag are used to identify the system.

The information tag is installed vertically and can be found on the left side of the chassis in front view, it includes Express Service Tag label and QR code on left-hand side and Dell branding to the right-hand side of the information tag.

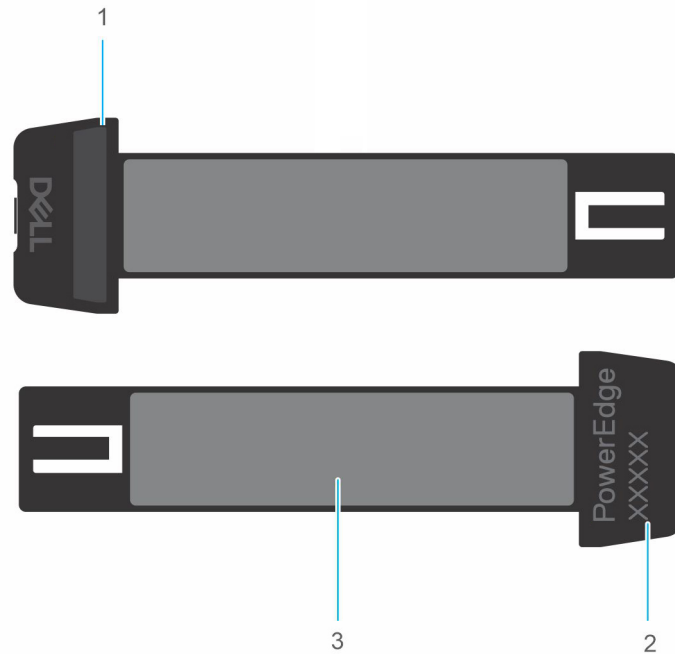

Figure 4. Locating the Service Tag of your system

1. Dell branding
2. PowerEdge model
3. Service Tag, Express Service Tag label, and QR code

The Mini Enterprise Service Tag (MEST) label is on the rear cover of the system. The MEST includes the Service Tag (ST), Express Service Code (Exp Svc Code), and Manufacture Date (Mfg. Date). The Exp Svc Code is used by Dell to route support calls to the appropriate personnel.

Alternatively, the Service Tag information is on a label on the left wall of the system.

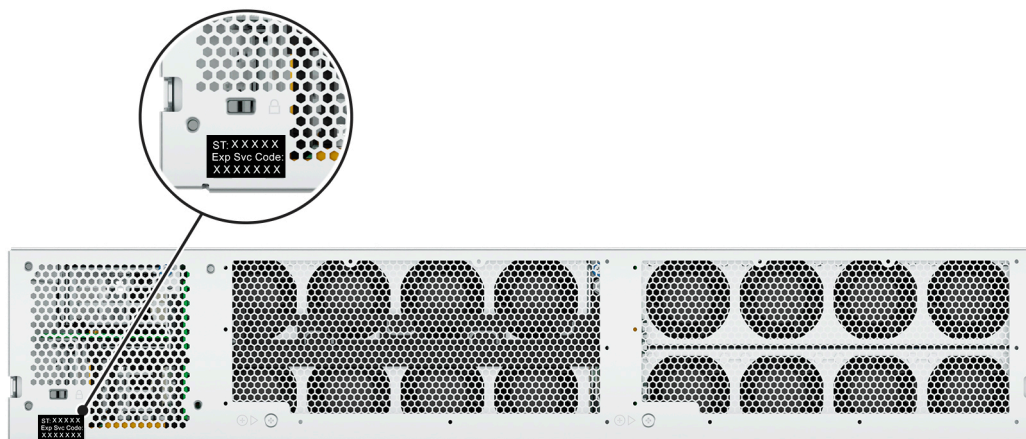

Figure 5. MEST label

System information label

Figure 6. Mechanical overview, System tasks

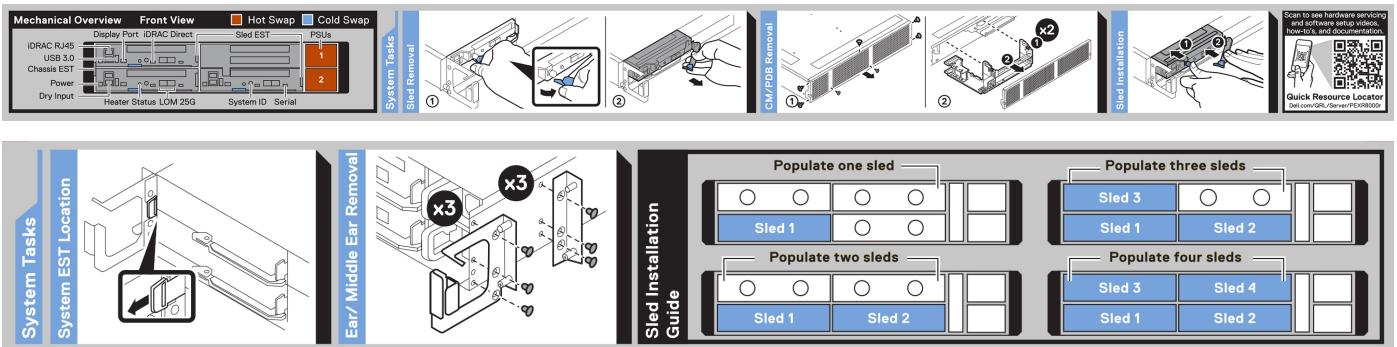

Figure 7. System tasks, Sled installation guide

Rail sizing and rack compatibility matrix

For specific information about the rail solutions compatible with your system, see the *Dell Enterprise Systems Rail Sizing and Rack Compatibility Matrix* available at https://i.dell.com/sites/csdocuments/Business_solutions_engineering-Docs_Documents/en/rail-rack-matrix.pdf.

The document provides the information that is listed below:

- Specific details about rail types and their functionalities.
- Rail adjustability range for various types of rack mounting flanges.
- Rail depth with and without cable management accessories.
- Types of racks that are supported for various types of rack mounting flanges.

Key factors governing proper rail selection include the following:

- Spacing between the front and rear mounting flanges of the rack.
- Type and location of any equipment that is mounted in the back of the rack such as power distribution units (PDUs).
- Overall depth of the rack.

The static rails offer a greater adjustability range and a smaller overall mounting footprint than the sliding rails because of their reduced complexity and lack of need for CMA support. The static rails support a wider variety of racks than the sliding rails. However, they do not support serviceability in the rack and are thus not compatible with the CMA. The static rails are also not compatible with SRB.

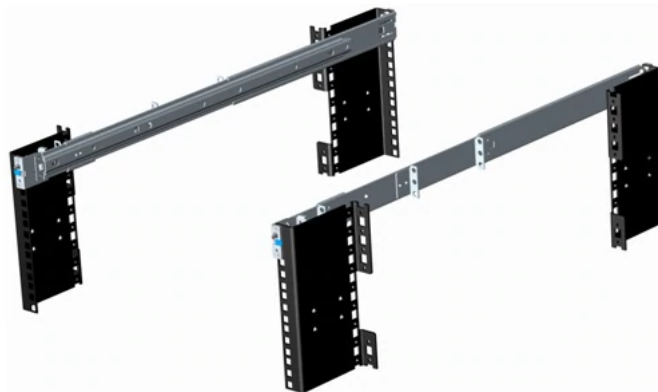

Figure 8. Static rails

Static rails features summary

Static rails for 4-post and 2-post racks:

- Supports Stab-in installation of the chassis to the rails.
- Support tool-less installation in 19" EIA-310-E compliant square or unthreaded round hole 4-post racks including all generations of Dell racks.
- Support tooled installation in 19" EIA-310-E compliant threaded hole 4-post and 2-post racks.
- Support for tooled installation in Dell Titan or Titan-D rack.

NOTE:

- Screws are not included with the static rail kit since racks are offered with various thread types. The screws are provided for mounting static rails in racks with threaded mounting flanges.
- Screw head diameter should be 10 mm or less.

Rack Installation

Options	Links to document on Dell support site	Document titles
B31 Rails	https://www.dell.com/poweredgemanuals > XR Servers> PowerEdge XR8000r	B31 Rack Installation Guide

Technical specifications

The technical and environmental specifications of your system are outlined in this section.

Topics:

- Chassis dimensions
- System weight
- PSU specifications
- Power module assembly
- PowerEdge XR sleds ports and connectors
- Environmental specifications

Chassis dimensions

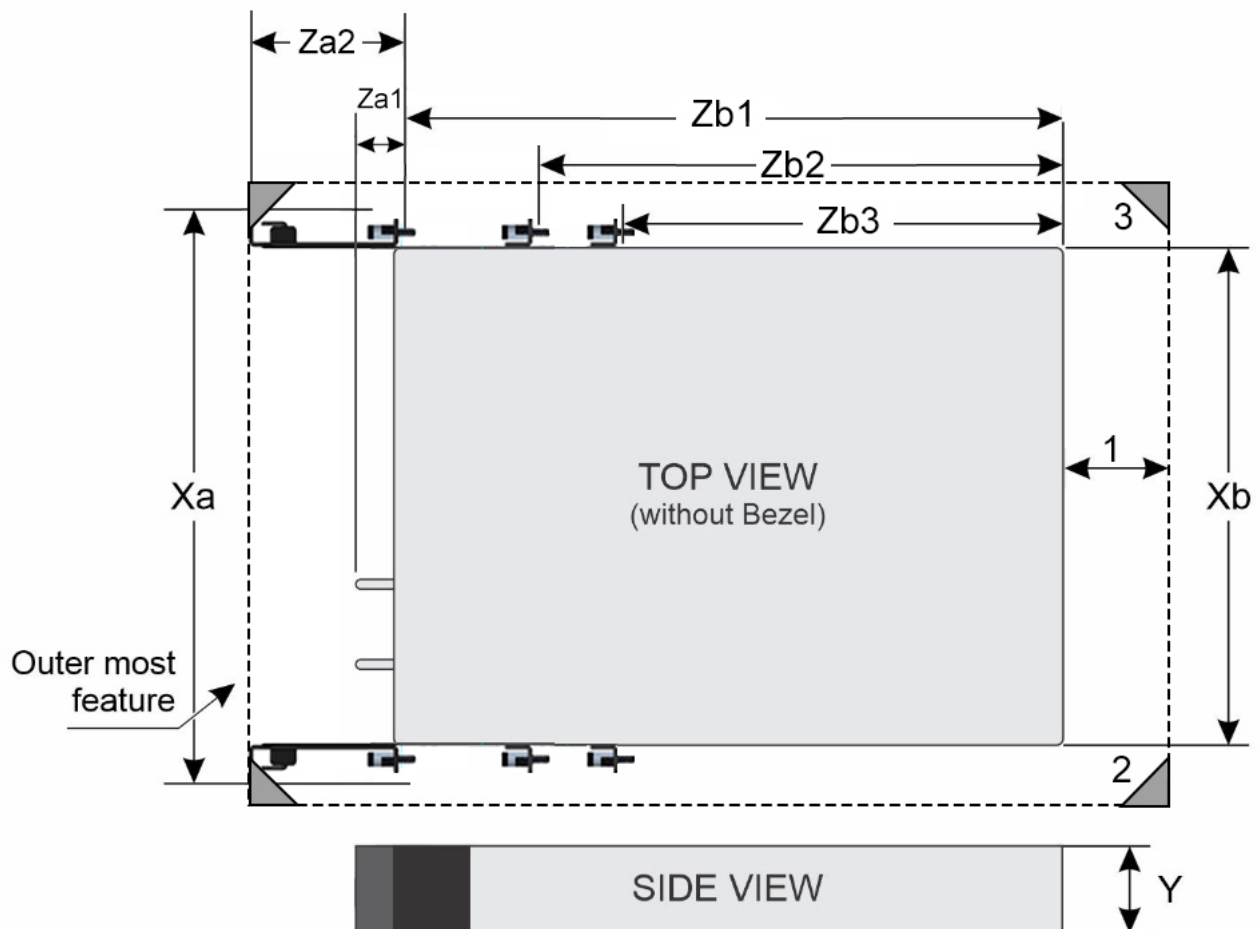

Figure 9. Chassis dimensions

Table 4. PowerEdge XR8000r chassis dimensions

Xa	Xb	Y	Za1	Za2	Zb1	Zb2	Zb3
482 mm (18.97 inches) includes rack mount ear.	448 mm (17.63 inches)	87.05 mm (3.42 inches)	30.4 mm (1.19 inches) Bezel not supported	89 mm (3.50 inches) with cable management kit included	423 mm (16.65 inches)	343 mm (13.50 inches)	293 mm (11.53 inches)

NOTE: The XR8000r can support racks/cabinets with a minimum space of 30.4 mm between the front post of the rack and the inside surface of the rack door, without the included cable management kit. The minimum front space required might be limited by front cable bending. When using the included cable management kit, the XR8000r can support racks/cabinets with a minimum distance of 89 mm between the front post of the rack and the inside surface of the rack door. Other important parameters in the image are:

1. Minimum exhaust gap (between chassis rear and cabinet’s rear door) required for thermal performance:
 - a. 50 mm minimum for ambient temperatures up to 55°C
 - b. 55 mm minimum for ambient temperatures 55 - 65°C
2. Four post rack.
3. 19-inch or 23-inch width cabinet boundary and 600 mm (23.62 inches) minimum cabinet depth.

System weight

Table 5. PowerEdge XR8000r system weight

System configuration	Maximum weight (with all drives/SSDs)
Weight of chassis without sleds	5.82 kg (12.8 pounds)
Weight of chassis with two XR8620t sleds	18.52 kg (40.84 pounds)

Table 6. PowerEdge system weight handling recommendations

Chassis weight	Description
40 pounds - 70 pounds	Recommend two persons to lift.
70 pounds- 120 pounds	Recommend three persons to lift.
≥ 121 pounds	Recommend to use a server-lift.

NOTE: If moving the chassis, it is recommended to remove all the sleds from the chassis.

PSU specifications

The PowerEdge XR8000r system supports up to two AC or DC power supply units (PSUs).

Table 7. PSU specifications

PSU	Class	Heat dissipation (maximum) (BTU/hr)	Frequency (Hz)	Voltage	AC		DC	Current (A)
					High line 200–240 V	Low line 100–120 V		
1800 W Mixed Mode	Titanium	6750 BTU/hr	50/60 Hz	200–240 V AC	1800 W	N/A	N/A	10 A
		6750 BTU/hr	N/A	240 V DC	N/A	N/A	1800 W	8.2 A

Table 7. PSU specifications (continued)

PSU	Class	Heat dissipation (maximum) (BTU/hr)	Frequency (Hz)	Voltage	AC		DC	Current (A)
					High line 200–240 V	Low line 100–120 V		
1400 W Mixed Mode	Platinum	5250 BTU/hr	50/60 Hz	100–240 V AC	1400 W	1050 W	N/A	12 A - 8 A
		5250 BTU/hr	N/A	240 V DC	N/A	N/A	1400 W	6.6 A
1400 W DC	N/A	5310 BTU/hr	N/A	-48—(-60) V	N/A	N/A	1400 W	33.5 A
1100 W DC	N/A	4265 BTU/hr	N/A	-48—(-60) V	N/A	N/A	1100 W	27 A
800 W DC	N/A	3219 BTU/hr	N/A	-48—(-60) V	N/A	N/A	800 W	20 A

- NOTE:** To update PSU firmware successfully, it is necessary to have both PSUs installed in the chassis.
- NOTE:** All PSUs come in Reverse Airflow (RAF) offerings (Reverse Airflow PSUs).
- NOTE:** This system is also designed to connect to the IT power systems with a phase-to-phase voltage not exceeding 240 V.
- NOTE:** Heat dissipation is calculated using the PSU wattage rating.
- NOTE:** For information about DC PSU cabling instructions, see the Cabling instructions for - (48 - 60) V DC power supply Tech sheet that is shipped with your DC PSU or go to <https://www.dell.com/poweredgemanuals> > XR Servers > PowerEdge XR8000r > Select This Product > Documentation > Manuals and Documents > Cabling instructions for - 48 - 60 V DC power supply
- NOTE:** When selecting or upgrading the system configuration, to ensure optimum power utilization, verify the system power consumption with the Enterprise Infrastructure Planning Tool available at [Dell.com/calculator](https://www.dell.com/calculator).

Power module assembly

The Dell PowerEdge XR8000r has a power module assembly which consists of two power distribution boards (PDBs) and are connected to each other so either or both power supplies can power the whole chassis. The power distribution board (PDB) at the bottom also has chassis manager board to manage the chassis.

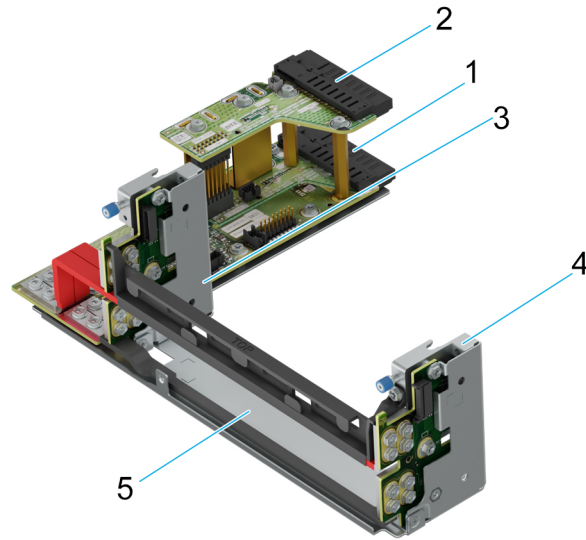

Figure 10. Power module assembly specifications

Table 8. Power module assembly

Item	Component	Description
1	Power distribution board 2/ Chassis Manager (PDB2/CM)	This is the power distribution board which provides power to the chassis components. The PSU 2 slot is on the PDB 2. Chassis Manager (CM) is also integrated on this board.
2	Power distribution board 1 (PDB1)	This is the power distribution board which provides power to the chassis components. The PSU 1 slot is on the PDB 1.
3	Power Interposer Board (PIB)	The power interposer board (PIB) provides power to the 1U and 2U sleds.
4	Power Interposer Board (PIB)	The power interposer board (PIB) provides power to the 1U and 2U sleds.
5	Power module tray	The power module tray houses the complete power module assembly.

PowerEdge XR sleds ports and connectors

PowerEdge XR8610t

Table 9. PowerEdge XR8610t externally accessible ports and connectors

Connector	Description
USB ports and connectors	<ul style="list-style-type: none"> • One USB 3.0-compliant port on the front of the sled. • One Micro-AB USB 2.0-compliant port for iDRAC Direct on the front of the sled. • One RJ45 port for iDRAC remote management (dedicated port only) on the front of the sled. • One RJ45 with port for dry contact input connection. • One Mini-DisplayPort on the front of the sled. • Two (optional) 25 GbE SFP 28 embedded LAN on Motherboard (LOM) ports.

Table 9. PowerEdge XR8610t externally accessible ports and connectors

Connector	Description
	<ul style="list-style-type: none"> One Micro-USB connector for RS232 serial port.

PowerEdge XR8620t

Table 10. PowerEdge XR8620t externally accessible ports and connectors

Ports and connectors
<ul style="list-style-type: none"> One USB 3.0-compliant port on the front of the sled. One dedicated micro USB 2.0-compliant port for iDRAC Direct on the front of the sled. One RJ45 port for iDRAC remote management (dedicated port only) on the front of the sled. One RJ45 port for dry contact input connection. One Mini-DisplayPort on the front of the sled. Two (optional) 25 GbE SFP 28 embedded LAN on Motherboard (LOM) ports. One Micro-USB connector for RS232 serial port.

Environmental specifications

NOTE: For additional information about environmental certifications, refer to the *Product Environmental Datasheet* located with the *Documentation* on www.dell.com/support/home.

Table 11. Operating and non-operating temperature considerations

Description	Temperature range
Operating temperature range for rear air-flow (RAF) configuration	-5 to <55°C with a startup temperature of 5°C
Ambient temperature for rear air-flow (RAF)	55°C
Non-operating temperature range	-40 to 85°C

Environmental Considerations

The PowerEdge XR8000r system is targeted for edge deployments and it meets all the additional standards for thermal, shock, vibration parameters.

Table 12. Environmental considerations

Industry	Configuration	Description
Telco	GR-1089-CORE	Electromagnetic Compatibility and Electrical Safety – Generic Criteria for Network Telecommunications Equipment
	GR-63-CORE	NEBS Requirements: Physical Protection
	SR-3580 (NEBS Level 3)	NEBS Criteria Levels
	GR-3108-CORE (Class 1)	Network Equipment in the Outside Plant (OSP). An exception is made for cold boot at 0°C instead of 5°C in systems without heating enabled
Safety	N/A	LDV, IEC/EN, CFR, CSA
EMC	N/A	EN, CISPR, ES, DTAG, CFR, ICES, VCCI
EMV	N/A	RoHS, WEEE, EN, ECE

 **NOTE:** Support operation temperature for the chassis is -20°C ~ 65°C. The sleds limitations are different from the chassis limitations, see dell.com/support. Enter service tag or product name to see the environmental specifications of the sled.

Installing and removing system components

Topics:

- [Safety instructions](#)
- [Before working inside your system](#)
- [After working inside your system](#)
- [Recommended tools](#)
- [XR8000r chassis](#)
- [Rear cover](#)
- [Power module assembly](#)
- [Power supply unit](#)

Safety instructions

CAUTION: Many repairs may only be done by a certified service technician. You should only perform troubleshooting and simple repairs as authorized in your product documentation, or as directed by the online or telephone service and support team. Damage due to servicing that is not authorized by Dell is not covered by your warranty. Read and follow the safety instructions that are shipped with your product.

NOTE: It is recommended that you always use an antistatic mat and antistatic strap while working on components inside the system.

Before working inside your system

Prerequisites

Follow the safety guidelines listed in the [Safety instructions](#).

Steps

1. Disconnect the system from the electrical outlet and disconnect the peripherals.
2. If applicable, remove the system from the rack.
For more information, see the *Rail Installation Guide* relevant to your rail solutions at www.dell.com/poweredgemanuals.

After working inside your system

Prerequisites

Follow the safety guidelines listed in [Safety instructions](#).

Steps

1. If applicable, install the system into the rack.
For more information, see the *Rail Installation Guide* relevant to your system at www.dell.com/poweredgemanuals.
2. Reconnect the peripherals and connect the system to the electrical outlet, and then power on the system.

Recommended tools

You may need some or all of the following tools to perform the removal and installation procedures:

You need the following tools to assemble the cables for a DC power supply unit:

- AMP 90871-1 hand-crimping tool or equivalent
- Tyco Electronics 58433-3 or equivalent
- Wire-stripper pliers to remove insulation from size 10 AWG solid or stranded, insulated copper wire

i **NOTE:** Use alpha wire part number 3080 or equivalent (65/30 stranding).

i **NOTE:** For information about DC PSU cabling instructions, see the Cabling instructions for - (48 - 60) V DC power supply Tech sheet that is shipped with your DC PSU or go to <https://www.dell.com/poweredgemanuals> > XR Servers > PowerEdge XR8000r > Select This Product > Documentation > Manuals and Documents > Cabling instructions for - 48 - 60 V DC power supply

XR8000r chassis

Removing a sled blank

Prerequisites

Follow the safety guidelines listed in [Safety instructions](#).

Steps

Pull the sled blank to remove it from the enclosure.



Figure 11. Removing a sled blank

Next steps

Install a sled or sled blank.

Installing a sled blank

Prerequisites

Follow the safety guidelines listed in [Safety instructions](#).

Steps

1. Align the sled blank with the bay of the chassis.
2. Insert and push the sled blank, until it locks into place.



Figure 12. Installing a sled blank

Removing a sled

Prerequisites

1. Follow the safety guidelines listed in the [Safety instructions](#).
2. Remove the front bezel, if applicable.

Steps

1. Pull the blue lever on the sled to release the sled handle.
2. Holding the sled handle, slide the sled out of the enclosure.

NOTE: The numbers on the image do not depict the exact steps. The numbers are for representation of sequence.

CAUTION: Support the system with both hands while sliding it out of the enclosure.



Figure 13. Removing a sled from XR8000r

Next steps

[Installing the sled](#)

Installing a sled

Prerequisites

Follow the safety guidelines listed in [Safety instructions](#).

Steps

1. Pull the blue lever on the sled to free the sled handle.
2. Holding the sled with both hands, align the sled along the sled-bay into the chassis.
3. Slide the sled into the chassis, ensure that the sled handle is in lock position.
4. Push the sled handle inwards so that it locks into place and secures the sled in the chassis.

NOTE: The numbers on the image do not depict the exact steps. The numbers are for representation of sequence.



Figure 14. Installing a sled into XR8000r

Next steps

Follow the procedure listed in [After working inside your system.](#)

Rear cover

Removing the rear cover

Prerequisites

Follow the safety guidelines listed in the [Safety instructions.](#)

Steps

1. Using the Torx 8 screwdriver, remove the screws that secure the rear cover on to the chassis.
2. Pull the rear cover to disengage from the chassis.

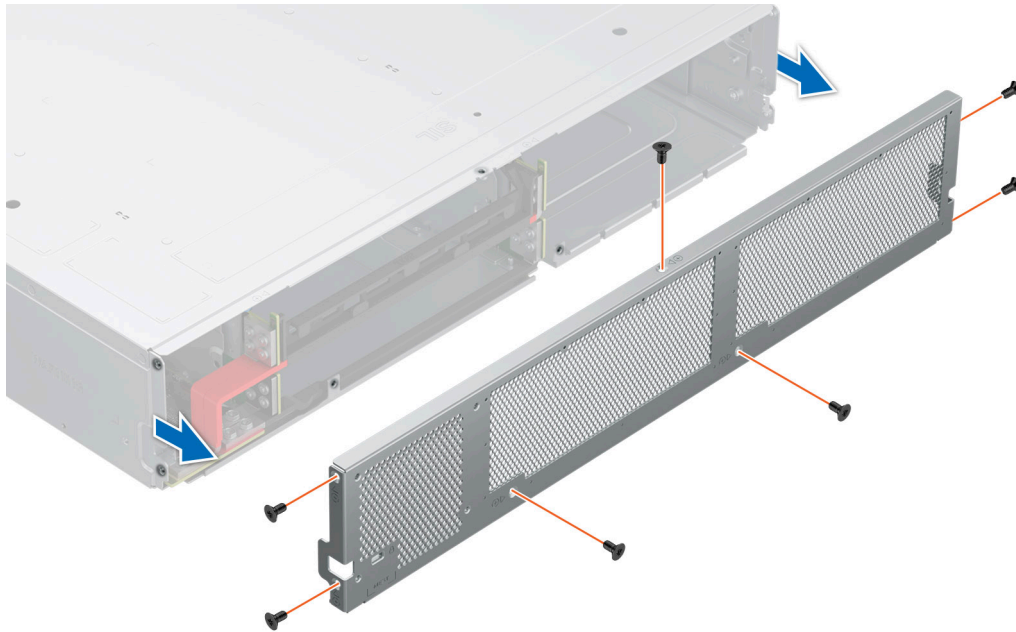

Figure 15. Removing the rear cover

Next steps

Replace the rear cover.

Installing the rear cover

Prerequisites

Follow the safety guidelines listed in the [Safety instructions](#).

Steps

1. Align and insert the cover on the rear of the chassis.
2. Using the Torx 8 screwdriver, tighten the screws that secure the rear cover on to the chassis.

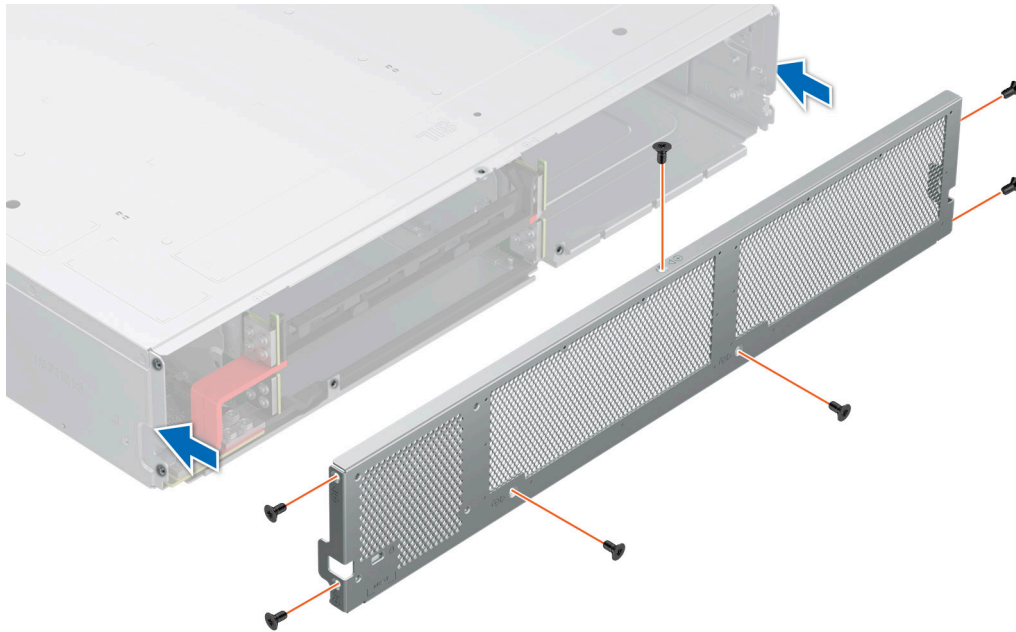

Figure 16. Installing the rear cover

Power module assembly

Removing power module assembly

Prerequisites

1. Follow the safety guidelines listed in the [Safety instructions](#).
2. [Remove the rear cover](#).
3. Remove the [sleds](#).
4. Remove the [power supply units](#).

Steps

1. Using a Phillips 2 screwdriver, loosen the two captive screws.
2. Pull the power tray along with the power module assembly (PDB) from the chassis.

(i) NOTE: The numbers on the image do not depict the exact steps. The numbers are for representation of sequence.

(i) NOTE: Support the power tray with both hands while sliding it out of the chassis.

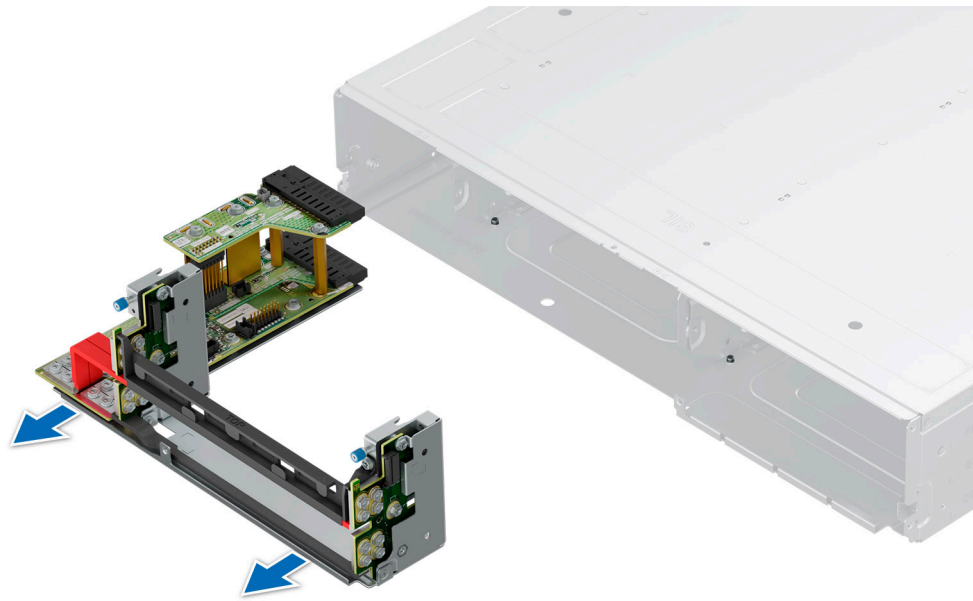

Figure 17. Removing power module assembly

Next steps

Replace power module assembly.

Installing the power module assembly

Prerequisites

Follow the safety guidelines listed in the [Safety instructions](#).

Steps

1. Align the power tray with four pins in the chassis and insert the power tray along with the power module assembly (PDB) into the chassis.
2. Fasten the two captive screws using Phillips 2 screwdriver.

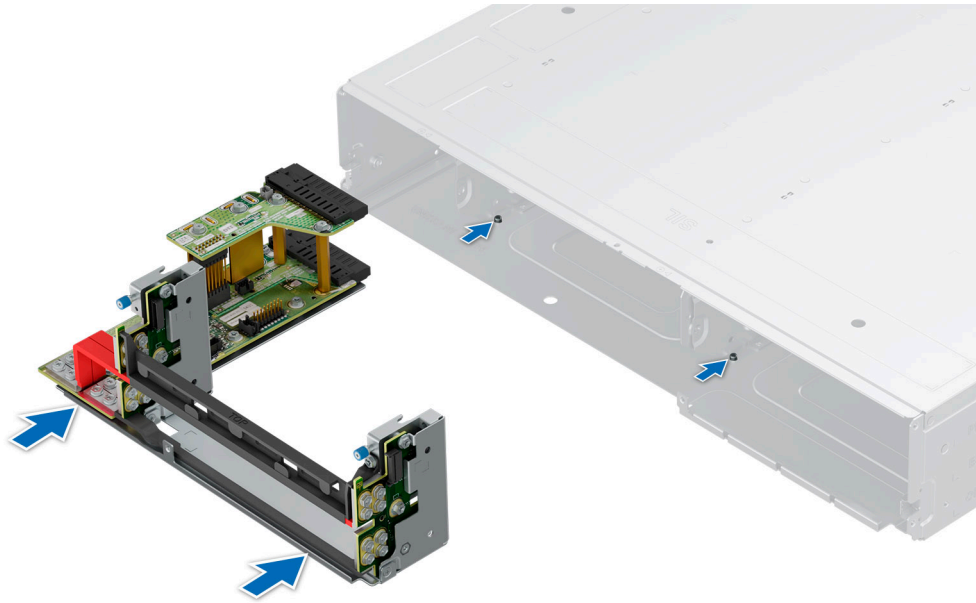

Figure 18. Installing the power module assembly

3. Install the rear cover.

Next steps

Follow the procedure listed in [After working inside your system..](#)

Power supply unit

NOTE: While replacing the hot swappable PSU, after next server boot; the new PSU automatically updates to the same firmware and configuration of the replaced one. For updating to the latest firmware and changing the configuration, see the *Lifecycle Controller User's Guide* at <https://www.dell.com/idracmanuals>.

Removing a power supply unit blank

Prerequisites

Follow the safety guidelines listed in the [Safety instructions](#).

Steps

Pull the PSU blank out of the system.

CAUTION: To ensure proper system cooling, the PSU blank must be installed in the second PSU bay in a non-redundant configuration. Remove the PSU blank only if you are installing a second PSU.



Figure 19. Removing a power supply unit blank

Next steps

Replace the PSU or PSU blank.

Removing a power supply unit

Prerequisites

CAUTION: The system requires one power supply unit (PSU) for normal operation. On power-redundant systems, remove and replace only one PSU at a time in a system that is powered on.

1. Follow the safety guidelines listed in the [Safety instructions](#).
2. Disconnect the power cable from the power outlet and from the Power Supply Unit (PSU) you intend to remove.
3. Remove the cable from the strap on the PSU handle.

NOTE: The PowerEdge XR8000r only supports reverse air flow (RAF) Power Supply Units (PSUs). The PSUs with blue straps are designed for reverse air flow (RAF).

NOTE: For information about DC PSU cabling instructions, see the Cabling instructions for - (48 - 60) V DC power supply Tech sheet that is shipped with your DC PSU or go to <https://www.dell.com/poweredgemanuals> > XR Servers > PowerEdge XR8000r > Select This Product > Documentation > Manuals and Documents > Cabling instructions for - 48 - 60 V DC power supply.

Steps

Press the orange release latch, and holding the PSU handle slide the PSU out of the PSU bay.



Figure 20. Removing a reverse air flow (RAF) power supply unit

Next steps

Replace the PSU or replace the PSU blank.

Installing a power supply unit

Prerequisites

1. Follow the safety guidelines listed in the [Safety instructions](#).
2. For systems that support redundant Power Supply Units (PSUs), ensure that both the PSUs are of the same type and have the same maximum output power.
 - NOTE:** The maximum output power (shown in watts) is listed on the PSU label.
3. Remove the PSU blank.
 - NOTE:** The PowerEdge XR8000r only supports reverse air flow (RAF) Power Supply Units (PSUs). The PSUs with blue straps are designed for reverse air flow (RAF).
 - NOTE:** For information about DC PSU cabling instructions, see the Cabling instructions for - (48 - 60) V DC power supply Tech sheet that is shipped with your DC PSU or go to <https://www.dell.com/poweredgemanuals> > XR Servers > PowerEdge XR8000r > Select This Product > Documentation > Manuals and Documents > Cabling instructions for - 48 - 60 V DC power supply.

Steps

Slide the PSU into the PSU bay until the release latch snaps into place.



Figure 21. Installing a reverse air flow (RAF) power supply unit

Next steps

1. Connect the power cable to the PSU, and plug the cable into a power outlet.

CAUTION: When connecting the power cable to the PSU, secure the cable to the PSU with the strap.

NOTE: When installing, hot swapping, or hot adding a new PSU, wait for 15 s for the system to recognize the PSU and determine its status. The PSU redundancy may not occur until discovery is complete. The PSU status indicator turns green to indicate that the PSU is functioning properly.

NOTE: For certain premium configurations with high power consumption, system PSU might stay with 2+0 mode only, 1+1 redundant mode is not available.

NOTE: While replacing the hot swappable PSU, after next server boot; the new PSU automatically updates to the same firmware and configuration of the replaced one. For more information about the Part replacement configuration, see the *Lifecycle Controller User's Guide* at <https://www.dell.com/idracmanuals>

Installing a power supply unit blank

Prerequisites

1. Follow the safety guidelines listed in the [Safety instructions](#).
2. Follow the procedure listed in [Before working inside your system](#).
3. [Remove the PSU](#).

NOTE: Install the power supply unit (PSU) blank only in the second PSU bay.

Steps

Align the PSU blank with the PSU bay and push it into the PSU bay until it clicks into place.



Figure 22. Installing a power supply unit blank

Getting help

Topics:

- [Recycling or End-of-Life service information](#)
- [Contacting Dell Technologies](#)
- [Accessing system information by using QRL](#)
- [Receiving automated support with Secure Connect Gateway \(SCG\)](#)

Recycling or End-of-Life service information

Take back and recycling services are offered for this product in certain countries. If you want to dispose of system components, visit www.dell.com/recyclingworldwide and select the relevant country.

Contacting Dell Technologies

Dell provides online and telephone based support and service options. If you do not have an active internet connection, you can find Dell contact information on your purchase invoice, packing slip, bill or Dell product catalog. The availability of services varies depending on the country and product, and some services may not be available in your area. To contact Dell for sales, technical assistance, or customer service issues follow these steps:

Steps

1. Go to www.dell.com/support/home.
2. Select your country from the drop-down menu on the lower right corner of the page.
3. For customized support:
 - a. Enter the system Service Tag in the **Enter a Service Tag, Serial Number, Service Request, Model, or Keyword** field.
 - b. Click **Search**.
The support page that lists the various support categories is displayed.
4. For general support:
 - a. Select your product category.
 - b. Select your product segment.
 - c. Select your product.
The support page that lists the various support categories is displayed.
5. For contact details of Dell Global Technical Support:
 - a. Click [Contact Technical Support](#).
 - b. The **Contact Technical Support** page is displayed with details to call, chat, or e-mail the Dell Global Technical Support team.

Accessing system information by using QRL

You can use the Quick Resource Locator (QRL) located on the Express service tag installed in front of the XR8000r chassis. There is also another QRL for accessing product information located on the back of the system cover.

Prerequisites

Ensure that your smartphone or tablet has a QR code scanner installed.

The QRL includes the following information about your system:

- How-to videos
- Reference materials, including the Installation and Service Manual, and mechanical overview
- The system service tag to quickly access the specific hardware configuration and warranty information
- A direct link to Dell to contact technical assistance and sales teams

Steps

1. Go to www.dell.com/qrl, and navigate to your specific product or
2. Use your smart phone or tablet to scan the model-specific Quick Resource (QR) code on your system or in the Quick Resource Locator section.

Quick Resource Locator for PowerEdge XR8000r system



Figure 23. Quick Resource Locator for PowerEdge XR8000r system

Receiving automated support with Secure Connect Gateway (SCG)

Dell Secure Connect Gateway (SCG) is an optional Dell Services offering that automates technical support for your Dell server, storage, and networking devices. By installing and setting up a Secure Connect Gateway (SCG) application in your IT environment, you can receive the following benefits:

- Automated issue detection — Secure Connect Gateway (SCG) monitors your Dell devices and automatically detects hardware issues, both proactively and predictively.
- Automated case creation — When an issue is detected, Secure Connect Gateway (SCG) automatically opens a support case with Dell Technical Support.
- Automated diagnostic collection — Secure Connect Gateway (SCG) automatically collects system state information from your devices and uploads it securely to Dell. This information is used by Dell Technical Support to troubleshoot the issue.
- Proactive contact — A Dell Technical Support agent contacts you about the support case and helps you resolve the issue.

The available benefits vary depending on the Dell Service entitlement purchased for your device. For more information about Secure Connect Gateway (SCG), go to www.dell.com/secureconnectgateway.

Documentation resources

This section provides information about the documentation resources for your system.

To view the document that is listed in the documentation resources table:

- From the Dell support site:
 1. Click the documentation link that is provided in the Location column in the table.
 2. Click the required product or product version.
-  **NOTE:** To locate the model number, see the front of your system.
- 3. On the Product Support page, click **Documentation**.
- Using search engines:
 - Type the name and version of the document in the search box.

Table 13. Additional documentation resources for your system

Task	Document	Location
Setting up your system	<p>For more information about installing and securing the system into a rack, see the Rail Installation Guide included with your rail solution.</p> <p>For information about setting up your system, see the <i>Getting Started Guide</i> document that is shipped with your system.</p>	www.dell.com/poweredgemanuals
Configuring your system	<p>For information about the iDRAC features, configuring and logging in to iDRAC, and managing your system remotely, see the Integrated Dell Remote Access Controller User's Guide.</p> <p>For information about understanding Remote Access Controller Admin (RACADM) subcommands and supported RACADM interfaces, see the RACADM CLI Guide for iDRAC.</p> <p>For information about Redfish and its protocol, supported schema, and Redfish Eventing implemented in iDRAC, see the Redfish API Guide.</p> <p>For information about iDRAC property database group and object descriptions, see the Attribute Registry Guide.</p> <p>For information about Intel QuickAssist Technology, see the Integrated Dell Remote Access Controller User's Guide.</p>	www.dell.com/poweredgemanuals
	<p>For information about earlier versions of the iDRAC documents.</p> <p>To identify the version of iDRAC available on your system, on the iDRAC web interface, click ? > About.</p>	www.dell.com/idracmanuals

Table 13. Additional documentation resources for your system (continued)

Task	Document	Location
	For information about installing the operating system, see the operating system documentation.	www.dell.com/operatingsystemmanuals
	For information about updating drivers and firmware, see the Methods to download firmware and drivers section in this document.	www.dell.com/support/drivers
Managing your system	For information about systems management software offered by Dell, see the Dell OpenManage Systems Management Overview Guide.	www.dell.com/poweredgemanuals
	For information about setting up, using, and troubleshooting OpenManage, see the Dell OpenManage Server Administrator User's Guide.	www.dell.com/openmanagemanuals > OpenManage Server Administrator
	For information about installing and using Dell Secure Connect Gateway, see the Dell Secure Connect Gateway Enterprise User's Guide.	https://www.dell.com/serviceabilitytools
	For information about partner programs enterprise systems management, see the OpenManage Connections Enterprise Systems Management documents.	www.dell.com/openmanagemanuals
Working with the Dell PowerEdge RAID controllers (if applicable)	For information about understanding the features of the Dell PowerEdge RAID controllers (PERC), Software RAID controllers, or BOSS card and deploying the cards, see the Storage controller documentation.	www.dell.com/storagecontrollermanuals
Understanding event and error messages	For information about the event and error messages generated by the system firmware and agents that monitor system components, go to qrl.dell.com > Look Up > Error Code , type the error code, and then click Look it up .	www.dell.com/qrl
Troubleshooting your system	For information about identifying and troubleshooting the PowerEdge server issues, see the Server Troubleshooting Guide.	www.dell.com/poweredgemanuals