



PL-CI8004
Forge Series
Cast Iron Sinks

Features

- Heavy-Duty Cast Iron Construction
- Solid Core for Long-Term Durability
- Chip-Resistant Porcelain Enamel Finish
- Non-Porous Surface Prevents Staining & Odor Absorption
- 8 Color Options
- Fits 8" Center Wall-Mount Faucets



Material

- Cast Iron

Installation

- Wall-Hung

Faucet Compatibility

- Model PL-8461
- Model PL-8410

Available Color/Finishes
Intended for reference only

Color	Description
	White
	Matte Black
	Light Green
	Light Pink
	Slate Blue
	Red
	Teal
	Yellow

6140 Ulmerton Road Clearwater, FL 33760

Phone: (727) 388-9895

Fax: (727) 362-1281

For the most current Specification Sheet, go to www.buildpelican.com





PL-CI8004
Forge Series
 Cast Iron Sinks

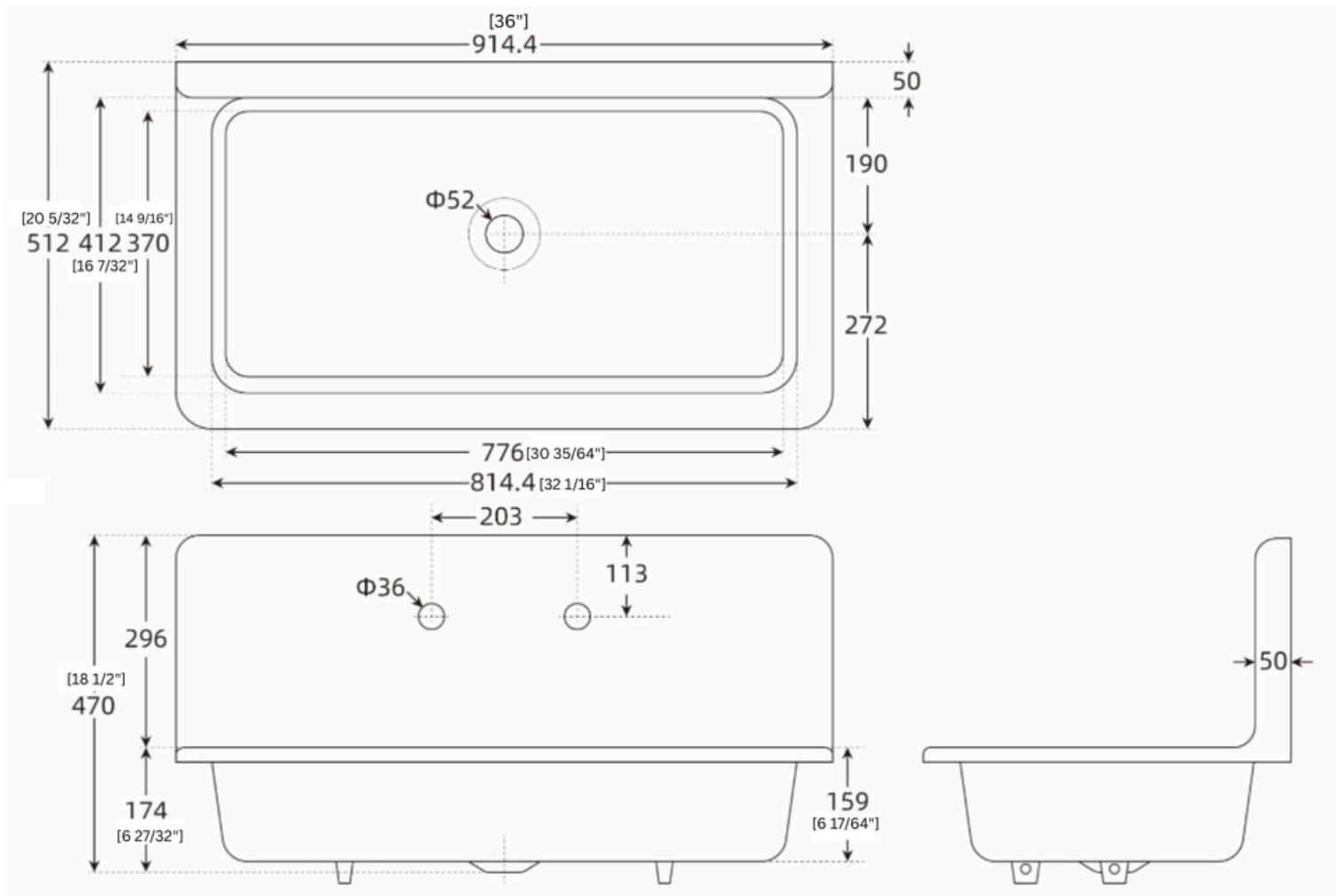

Technical Information

All product dimensions are nominal

Exterior Measurements: 36" x 20 5/32" x 18 1/2"

Interior Measurements: 32 1/16" x 16 7/32" x 6 17/64"

Installation Information

Install this product according to the installation instructions.

Warranty

See website for detailed warranty information.

JOB INFORMATION

JOB NAME: _____ MODEL SPECIFIED: _____ QUANTITY: _____
 DATE: _____ ARCHITECT/ENGINEER: _____
 CUSTOMER: _____ CONTRACTOR: _____

6140 Ulmerton Road Clearwater, FL 33760

Phone: (727) 388-9895

Fax: (727) 362-1281

For the most current Specification Sheet, go to www.buildpelican.com

