



5x4RU

6x3RU

IP55

25.6kWh Battery Cabinet -

IP55 rated field enclosure to suit rack-mount batteries and associated power conversion equipment

TECHNICAL SPECIFICATIONS

Model	EBC25H-ODFAN (c/w fan)
No. of modules	4RU x 5 units <i>(factory configured)</i> 3RU x 6 units <i>(2 x angled brackets included)</i>
Convection: Battery Space	DC 48V 120mm fans x 2
Convection: PCE Space	DC 48V 120mm fans x 2
Mounting	Floor
Securing	4 x Heavy Duty L brackets
Earthing	Plinth with 2 included Earthing Blocks
Battery Interconnection	By others subject to brand choice
Cable Entry	Floor mounted cable glands
Total Weight (nett)	170 kg
Total Weight (packaged)	183 kg

Construction

Body	2.0mm galvanised steel
Mounting Rails/Panels	2.0mm galvanised steel
Doors	2.0mm galvanised steel
Opening Degree	Front/Back door 120° Side doors 100°
Plinths	2.5mm galvanised steel (Screwed access covers all sides)
Colour	Powder coated RAL7035 (grey)
Thickness	80-120µm
Door Seal	(EPDM) Ethylene Propylene Diene Monomer Temperature Resistance B2
Cabinet Insulation	(NBR) Nitrile Butadiene Rubber (10mm) Temperature Resistance B2

Standards

IEC /AS standards	ANSI-310-D, IEC 297-2, DIN 41491/41494
Certification	CE, RoHS

Protection

Compliance Standard	IEC 60529:2013
IP rating	IP55
Warranty	36 Months (3 Years) *T&C Apply

FEATURES

The EBC25H-ODFAN is a fan cooled and insulated dual compartment battery storage solution suitable for indoor and outdoor installations.

- Innovative front-back design to separate batteries from power conversion equipment.
- Heavy duty and insulated galvanised steel construction.
- IP55 ingress rating.
- Multiple gasketed door access points via removable metal doors with three-point keyed-alike handle locks with staple for a padlock.
- Twin 48VDC fans with thermostat.
- 6 x adjustable height L brackets/rails for module installation (5 pre-installed).
- Handy DC 48V internal LED lights.
- Document pocket.
- Removable filters.
- 4 x floor mounting brackets.
- 4 x lifting hooks to assist with cabinet placement.



Also available with aircon unit
Model: EBC25H-ODAIR



All specifications are correct at time of creation. All specifications and operation conditions contained in this datasheet are subject to change or improvement without prior notice to the user. This data is for evaluation purposes only. No guarantee is intended or implied by this data. For clarification and updated information, please contact us.



5x4RU

6x3RU

IP55

DIMENSIONS (mm)

Complete * Door Fittings Not Included

Length/Depth	1000
Width	651
Height	1315

Battery Compartment

Max Battery Depth	427
Width (Between Rails)	447
Usable Rack Height	880

PCE Compartment

Length/Depth	425
Width	590
Height	1085

Escutcheon Area

Width	440
Height	1085
Max Equipment Height	395



Battery compartment side

PCE compartment side

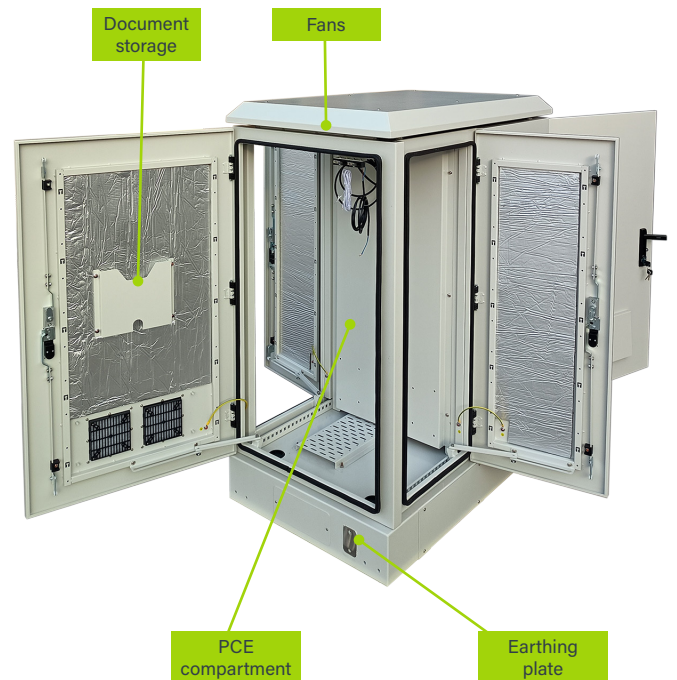

All specifications are correct at time of creation. All specifications and operation conditions contained in this datasheet are subject to change or improvement without prior notice to the user. This data is for evaluation purposes only. No guarantee is intended or implied by this data. For clarification and updated information, please contact us.



5x4RU

6x3RU

IP55

DRAWINGS

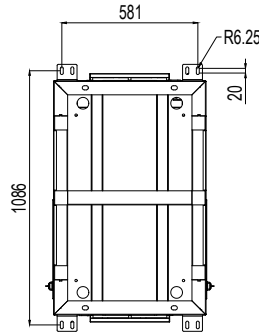

4-FAN(DC48 120mmFan)

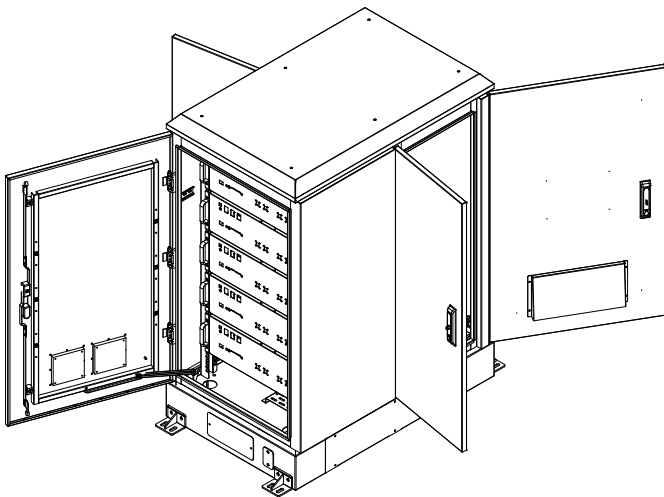
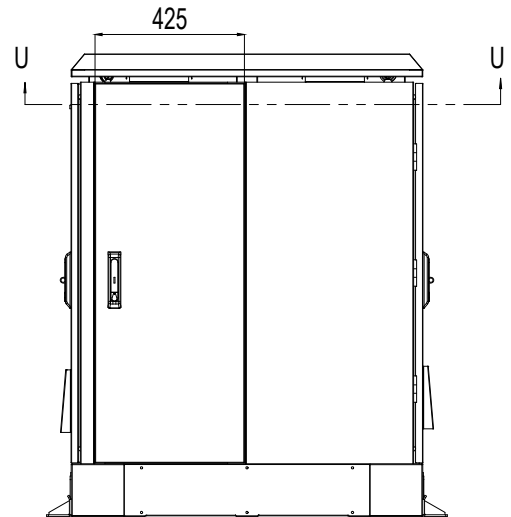
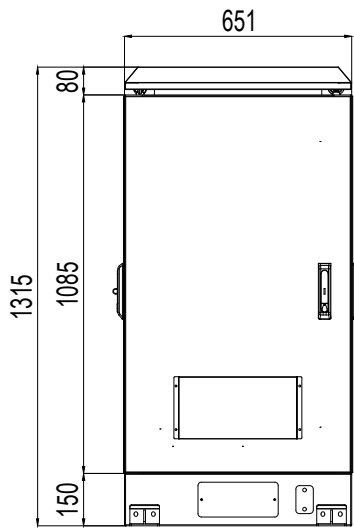
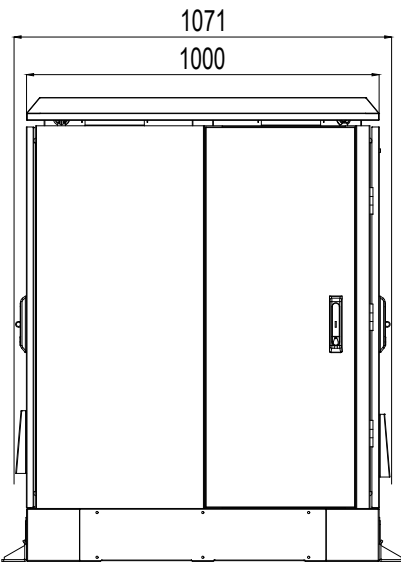
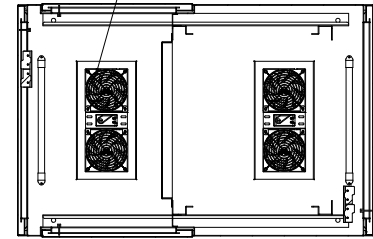

**Batteries depicted not included.*

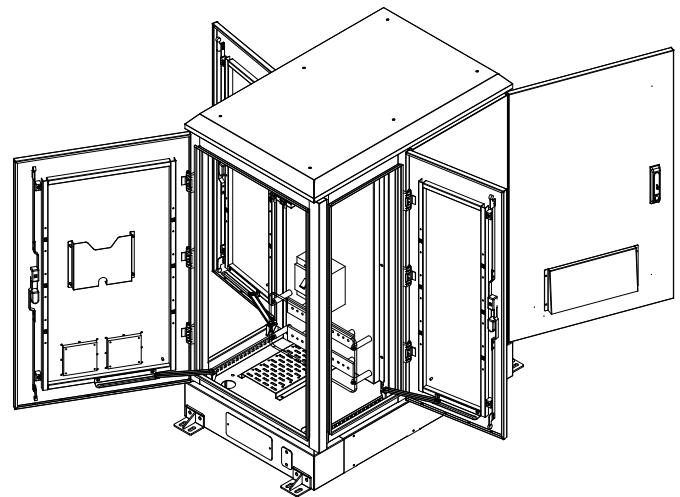

**DC breakers depicted not included.*

All specifications are correct at time of creation. All specifications and operation conditions contained in this datasheet are subject to change or improvement without prior notice to the user. This data is for evaluation purposes only. No guarantee is intended or implied by this data. For clarification and updated information, please contact us.