



8x4RU

10x3RU

IP55

40.92kWh Battery Cabinet -

IP55 rated field enclosure to suit rack-mount batteries and associated power conversion equipment

TECHNICAL SPECIFICATIONS

Model	EBC40H-ODFAN
No. of modules	4RU x 8 units (factory configured) 3RU x 10 units (2 x angled brackets included)
Convection: Battery Space	DC 48V 150mm Fans x 2
Convection: PCE Space	DC 48V 150mm Fans x 2
Mounting	Floor
Securing	4 x Heavy Duty L brackets (Long side mount)
Earthing	Plinth with 2 included Earthing Blocks (Long side mount)
Battery Interconnection	By others subject to brand choice
Cable Entry	Floor mounted cable glands (2 x 45mm per enclosure)
Total Weight (nett)	335 kg
Total Weight (packaged)	355 kg

Construction

Body	2.0mm galvanised steel
Mounting Rails/Panels	2.0mm galvanised steel
Doors	2.0mm galvanised steel
Opening Degree	Left/Right door 120°
Plinths	2.5mm galvanised steel (Screwed access covers all sides)
Colour	Powder coated RAL7035 (grey)
Thickness	80-120µm
Door Seal	(EPDM) Ethylene Propylene Diene Monomer Temperature Resistance B2
Cabinet Insulation	(NBR) Nitrile Butadiene Rubber (10mm) Temperature Resistance B2

Standards

IEC /AS standards	ANSI-310-D, IEC 297-2, DIN 41491/41494
Certification	CE, RoHS

Protection

Compliance Standard	IEC 60529:2013
IP rating	IP55
Warranty (Cabinet)	36 Months (3 Years) *T&C Apply

FEATURES

The EBC40H-ODFAN is a large fan cooled and insulated dual compartment battery storage solution suitable for indoor and outdoor installations.

- Side-by-side design to separate batteries from power conversion equipment.
- Heavy duty and insulated galvanised steel construction.
- IP55 ingress rating.
- Dual gasketed door access points via removable metal doors with three-point keyed-alike handle locks with staple for a padlock.
- Twin 48VDC 150mm fans with thermostat per compartment.
- 10 x adjustable height L brackets/rails for module installation (8 pre-installed).
- Handy DC 48V internal LED lights.
- Document pocket.
- Removable filters.
- 4 x floor mounting brackets.
- 4 x lifting hooks to assist with cabinet placement.



Also available with A/C unit
Model: EBC40H-ODAIR



All specifications are correct at time of creation. All specifications and operation conditions contained in this datasheet are subject to change or improvement without prior notice to the user. This data is for evaluation purposes only. No guarantee is intended or implied by this data. For clarification and updated information, please contact us.



8x4RU

10x3RU

IP55

DIMENSIONS (mm)

Complete * Door Fittings Not Included

Length/Depth	650
Width	1500
Height	2000

Battery Compartment

Max Battery Depth	480
Width	447
Usable Rack Height	1600

PCE Compartment

Length/Depth	500
Width	775
Height	1650

Escutcheon Area

Width	700
Height	1645
Max Equipment Height	460



Internal view

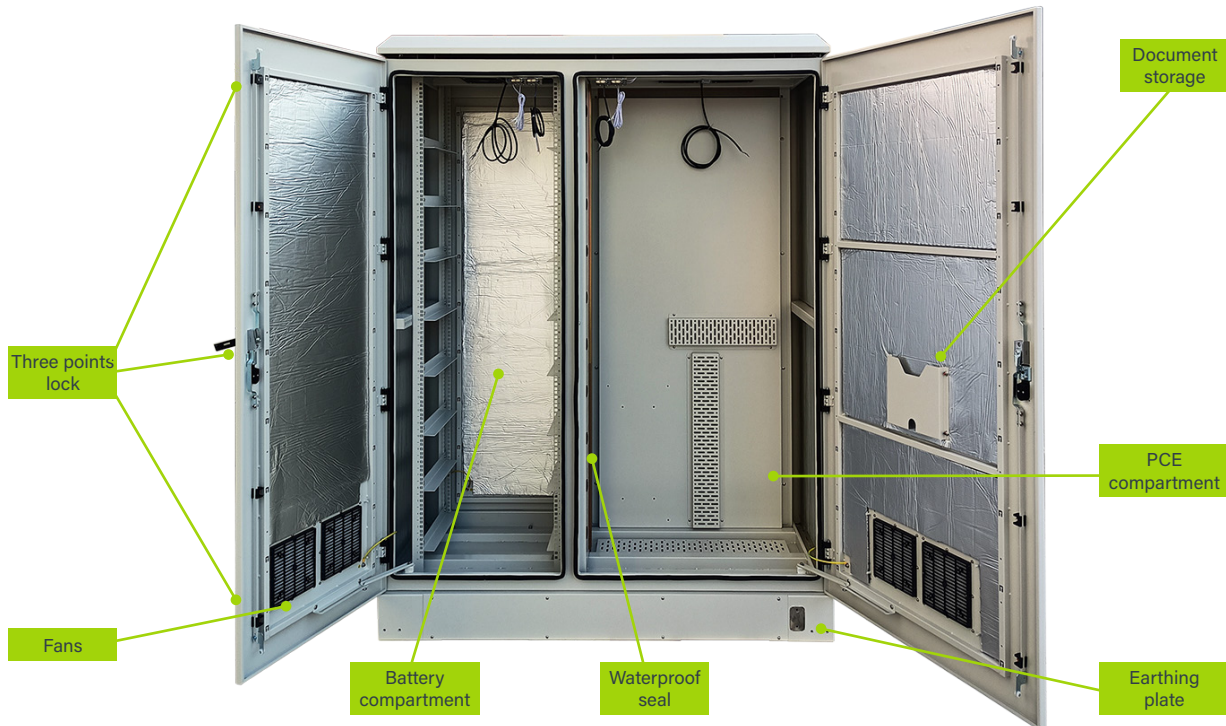

All specifications are correct at time of creation. All specifications and operation conditions contained in this datasheet are subject to change or improvement without prior notice to the user. This data is for evaluation purposes only. No guarantee is intended or implied by this data. For clarification and updated information, please contact us.



8x4RU

10x3RU

IP55

DRAWINGS

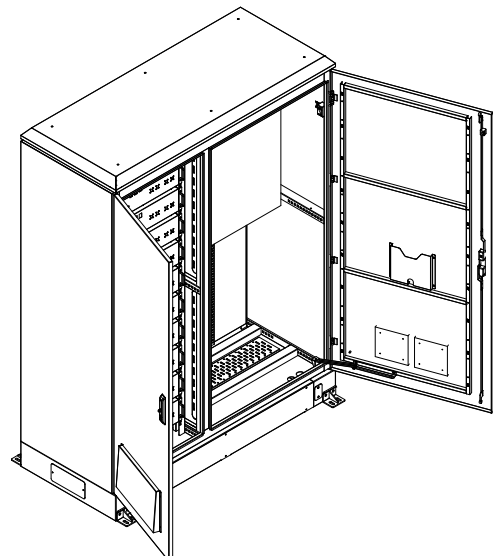
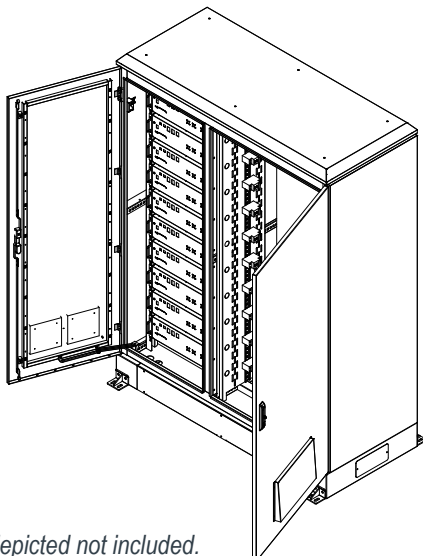
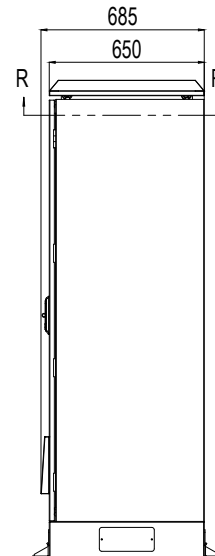
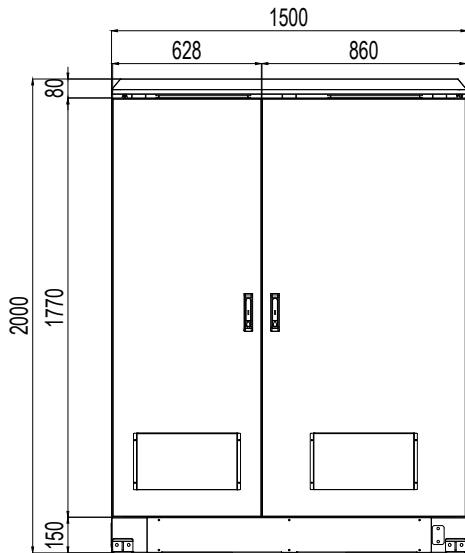
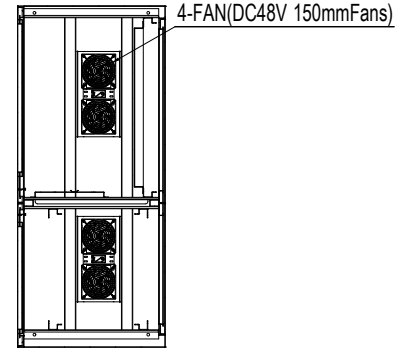
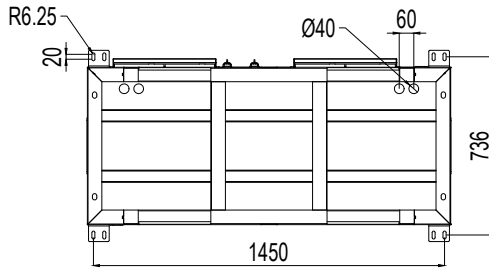

**Batteries depicted not included.*

All specifications are correct at time of creation. All specifications and operation conditions contained in this datasheet are subject to change or improvement without prior notice to the user. This data is for evaluation purposes only. No guarantee is intended or implied by this data. For clarification and updated information, please contact us.