

SOLID TOP CHEST FREEZERS

MODEL: MXSH19.4SHC MXSH23.6SHC MXSH30.0SHC



MXSH19.4SHC



MXSH23.6SHC



MXSH30.0SHC

Maxx Cold Select Series Chest Freezers with a solid hinged lid top is ideal for safely storing frozen food products such as meat, packaged foods, ice cream, vegetables, desserts and bagged ice. Interior storage basket(s) allow you to organize your products and quickly retrieve what you need. The oversized refrigeration system keeps your products safely stored even in extreme low or high ambient temperatures.

FEATURES AND CONSTRUCTION

- White powder coated steel exterior and aluminum interior
- Locking hinged top lid(s) with integrated handle
- Environmentally friendly, CFC-free urethane foam insulation helps store contents safely for up to 2 days in the event of a power outage
- Equipped with two (2) or two (2) heavy-duty coated wire storage basket(s)
- Equipped four (4) with 1.3" rollers for mobility
- Adjustable wire shelves (one per section/door)
- Integrated condensate evaporator pan eliminates the need for a floor drain connection
- Manual defrost

ELECTRIC

115V / 60Hz / 1Ph
 (230V / 50-60Hz / 1Ph is available as an option)
 6' (2m) NEMA 5-15P cord set included

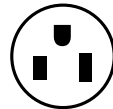

NEMA 5-15P

3RD PARTY APPROVALS



Intertek

Certified to ANSI NSF 7



Intertek

Certified to ANSI UL 471



DOE 2017 Compliant

MAXX COLD WARRANTY (USA / CANADA)

Contact Maxx Cold for warranty statement at
 TechnicalServices@TheLegacyCompanies.com or 877.368.2797

TEMPERATURE

Holding temperature -11.2°F to -1°F (-24°C to -18°C)

- Efficient, cold wall system delivers even temperature regulation throughout the storage compartment
- Easily adjustable control system
- Oversized refrigeration and efficient foam insulation provides rapid recovery and excellent temperature regulation

MAXX COLD SELECT SERIES SOLID TOP CHEST FREEZERS

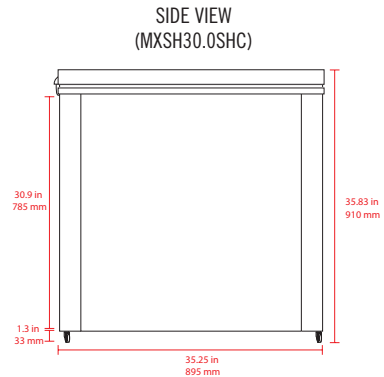
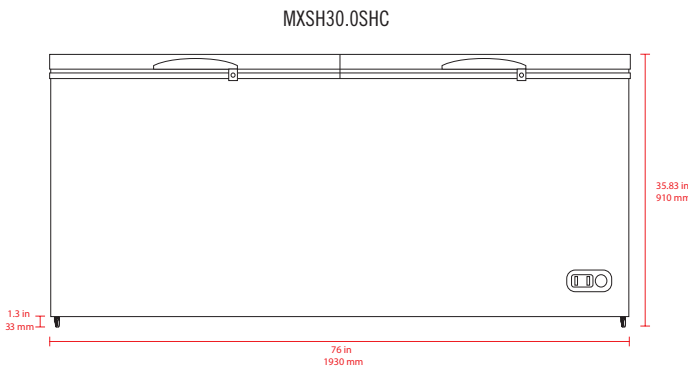
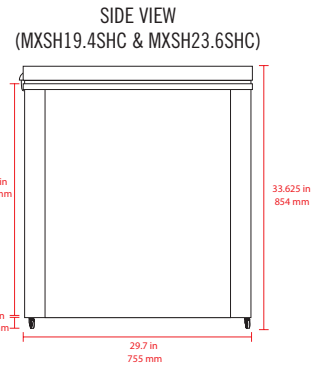
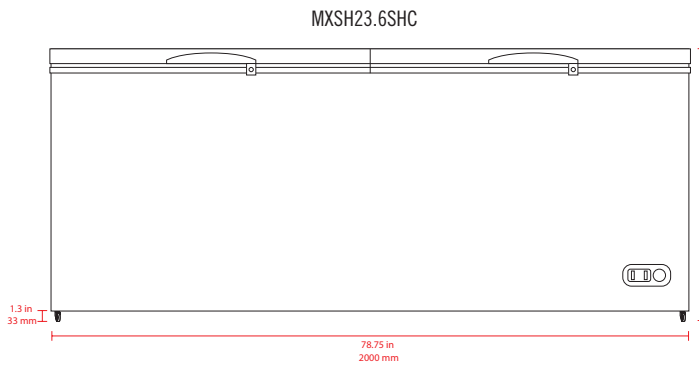
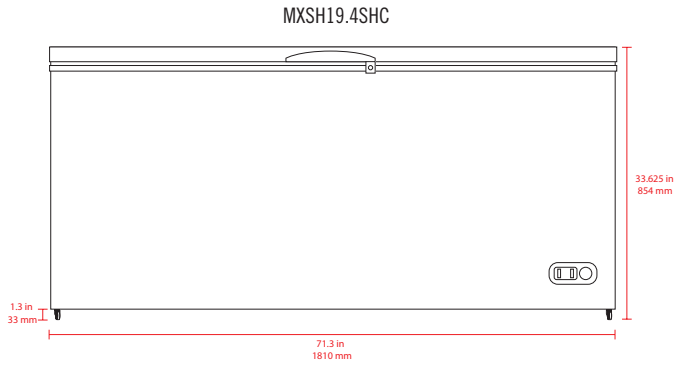

MODEL	EXTERNAL DIMENSIONS	INTERNAL DIMENSIONS (W x D x H / Compressor Height)	CAPACITY	HOLDING TEMPERATURE RANGE	AMP DRAW	SHIPPING WEIGHT	REFRIGERANT AND CHARGE SIZE	LIDS/ BASKETS	ELECTRICAL
MXSH19.4SHC	71.3 x 29.7 x 33.625 1810 x 755 x 854 mm	65.35 x 19.72 x 26.58 / 10.24 1660 x 501 x 675 / 260 mm	19.4 Cu Ft (549 L)	-11.2°F to -1°F (-24°C to -18°C)	2.6A	205 lbs (93 kg)	R-290a 3.53 oz (100 g)	1 / 2	115V / 60Hz / 1Ph
MXSH23.6SHC	78.75 x 29.7 x 33.625 2000 x 755 x 854 mm	73.58 x 22.40 x 27.32 / 10.24 1869 x 569 x 694 / 260 mm	23.6 Cu Ft (669 L)	-11.2°F to -1°F (-24°C to -18°C)	2.1A	198.4 lbs (90 kg)	R-290a 4.94 oz (140 g)	2 / 2	115V / 60Hz / 1Ph
MXSH30.0SHC	76 x 35.25 x 35.83 1930 x 895 x 910 mm	69.60 x 26.61 x 29.92 / 10.24 1768 x 676 x 760 / 260 mm	30.0 Cu Ft (850 L)	-11.2°F to -1°F (-24°C to -18°C)	2.1A	242.5 lbs (110 kg)	R-290a 5.29 oz (150 g)	2 / 2	115V / 60Hz / 1Ph

INSTALLATION

- Unit may be installed in a non-air conditioned space such as a garage or basement without effecting performance