



Project Name: _____

Location: _____

Item #: _____ Qty: _____

Model: _____

BENCH TYPE POTATO & VEGETABLE PEELER

MODEL: S-15 S-15-T



S-15(-T)

A knife is suited for carving ship models and novelties but has no place in peeling potatoes and vegetables. Hand peeling is slow and costly. Speed up your menu production and save costly man hours in the kitchen with Blakeslee "No Gear" peeler. They are the ultimate in streamlined functional design and engineering achievement.

** The T in the model number indicates a TIMER is included with this model.*

FEATURES AND CONSTRUCTION

- 15lbs (23kg) - 20lbs (9kg) capacity in 1-3 minutes
- 0.33 HP motor
- Easy to clean
- Adjustable 5-minute timer for single-phase units (S-15-T) or on/off switch for three-phase units (S-15)
- Stainless steel exterior and driver shaft
- Cast aluminum discharge chute
- Dual V-belt
- Motor and drive unit sealed off against moisture to assure trouble free performance
- Dual V-belt drive provides speed reduction between motor and abrasive peeling disc for efficient peeling action
- Standard size V-belt for easy replacement
- Self-closing door

ELECTRIC

115V / 60Hz / 1Ph
208-230V / 60Hz / 1Ph
220-240V / 60Hz / 3Ph
Cord and plug included

3RD PARTY APPROVALS



BLAKESLEE WARRANTY (USA / CANADA)

Contact Blakeslee for warranty information.

Contact Blakeslee USA for details at service@blakesleeinc.com or 630.532.5021



BENCH TYPE POTATO & VEGETABLE PEELER

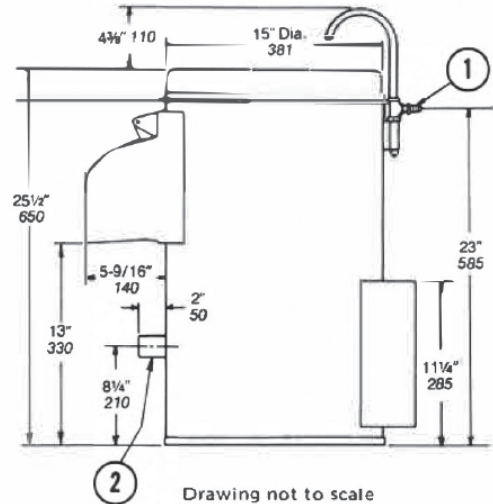
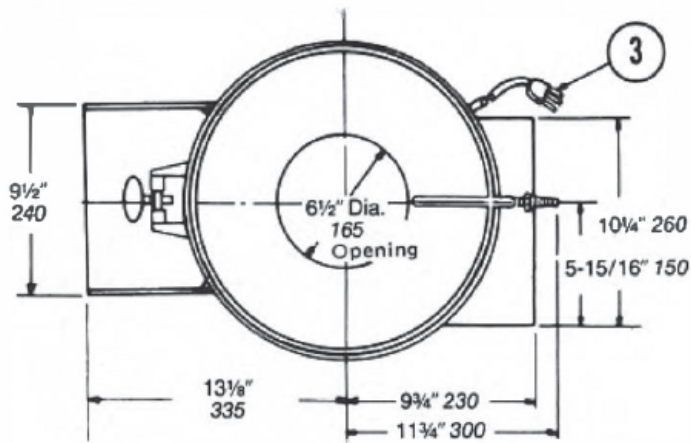

NO.	CONNECTION	FITTING	FUNCTION
1	Cold Water	1/2" (13 mm) Hose Fitting	Peel Flushing Spray
2	Waste-Sewer	1 1/2" (38 mm) Drain Tubing	Cylinder Drain
3	Electrical	1/3 HP Motor	Cord & Plug

APPROXIMATE SHIPPING SPECIFICATIONS

MODEL	UNIT DIMENSIONS	SHIPPING DIMENSIONS	ELECTRICAL	AMPS	UNIT WEIGHT	SHIPPING WEIGHT
S-15(-T)	20" x 20" x 25" (508 x 508 x 648 mm)	26.5" x 32.5" x 72" (673 x 826 x 1829 mm)	115V/60Hz/1Ph 208-230V/60Hz/1Ph 220-240V/6-Hz/3Ph	6A 3A 1.4A	110 lbs (50 kg)	136 lbs (61 kg)