



Project Name: _____

Location: _____

Item #: _____ Qty: _____

Model: _____

FLOOR TYPE POTATO & VEGETABLE PEELER

MODEL: XC-30 XC-30-T



XC-30(-T)

Blakeslee “No-Gear” peeler with 30-33lb capacity removes the thin outer skin of vegetables and saves all of the food value and flavor. Hand peeling wastes 20% of the vegetable and adds to your produce bills and labor cost. Includes a Stainless Steel Peel Trap.

** The T in the model number indicates a TIMER is included with this model.*

FEATURES AND CONSTRUCTION

- 30lbs (14kg) - 33lbs (15kg) capacity in 1-3 minutes
- 0.75 HP motor
- Easy to clean
- Adjustable 5-minute timer for single-phase units (XC-30-T) or on/off switch for three-phase units (XC-30)
- Stainless steel exterior, drive shaft and strainer basket
- Cast aluminum discharge chute Motor and Drive unit sealed off against moisture to assure trouble free performance
- Dual V-belt drive provides speed reduction between motor and abrasive peeling disc for efficient peeling action
- Standard size V-belt for easy replacement
- Self-closing door

ELECTRIC

115V / 60Hz / 1Ph
208-230V / 60Hz / 1Ph
220-240V / 60Hz / 3Ph
Cord and plug included

3RD PARTY APPROVALS



BLAKESLEE WARRANTY (USA / CANADA)

Contact Blakeslee for warranty information.

Contact Blakeslee USA for details at service@blakesleeinc.com or 630.532.5021

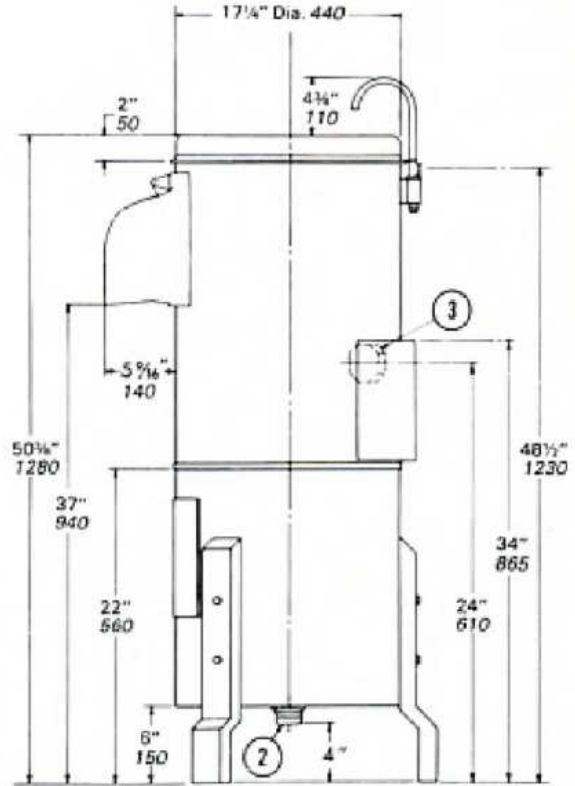
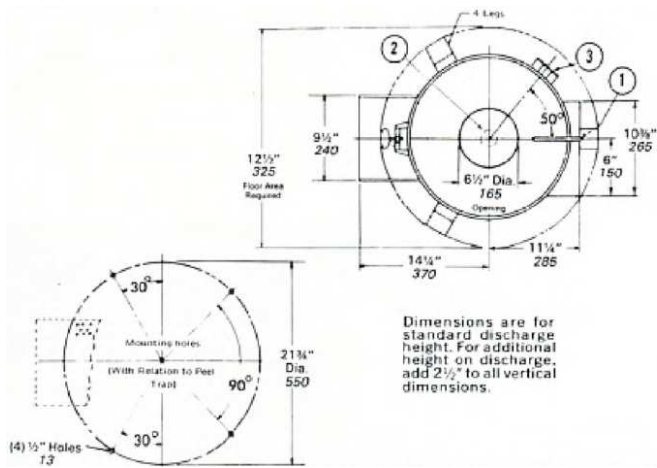

NO.	CONNECTION	FITTING	FUNCTION
1	Cold Water	1/2" (13 mm) Hose Fitting	Peel Flushing Spray
2	Waste-Sewer	2" (50 mm) N.P.T.	Cylinder Drain
3	Electrical	3/4 HP Motor	3-Wire 3" (76 mm) Electrical Box

APPROXIMATE SHIPPING SPECIFICATIONS

MODEL	UNIT DIMENSIONS	SHIPPING DIMENSIONS	ELECTRICAL	AMPS	UNIT WEIGHT	SHIPPING WEIGHT
XC-30(-T)	24" x 24" x 50.25" (610 x 610 x 1276 mm)	26.5" x 32.5" x 72" (673 x 826 x 1829 mm)	115V/60Hz/1Ph 208-230V/60Hz/1Ph 220-240V/6-Hz/3Ph	11.4A 5.7A 3.2A	160 lbs (72.6 kg)	186 lbs (84.4 kg)