

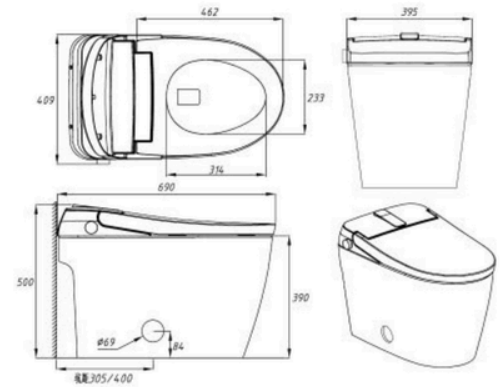

Product Size



Product Information

Size: 27.17x15.55x19.69in

Packing Size: 32.28*19.29*24.80in

Rough-in: 12in

Heating Method: Instant Heating

Flushing Method: Jet Siphon Type

Ceramic Body: With Water Tank























Color: White

Display mode: Fahrenheit

Net Weight: 88lb

Gross Weight: 99lb

Basic Functions

-  Remote Control Side Control Knob
-  Adjustable Water Temp.
-  Adjustable Seat Temp.
-  Adjustable Warm Air Temp.
-  Adjustable Water Pressure
-  Heated Seat
-  Rear Wash
-  Lady Wash
-  Oscillating Wash
-  Massage Wash
-  Cleaning Wand Self-Cleaning
-  Auto Deodorizer
-  Warm Air Dryer
-  Soft-Closing Lid and Seat
-  Nightlight
-  LED Screen Display
-  Auto Flush
-  One-touch Mode
-  Power On Self Test
-  Auto Flush (Close cover/ Off Seat)
-  Pre-moisture After Seated
-  Auto Open Seat (Foot Sensor)
-  Auto Open/ Close Cover (Rader Sensor)