



Project:

Item Number:

Quantity:

E131X, F131X GRAVITY FED TWIN TWIST COUNTERTOP MACHINES



DESCRIPTION

Twin twist, counter-top, gravity soft serve/yogurt freezer. Triple-duty freezer allows you to serve two individual flavors or combine them for a twist, produces quality product consistency from first cone to last. IntelliTec2™ control for worry-free operation.

F131 features a larger compressor for increased production capacity.

INTELLITEC2™ CONTROL FEATURES

- Programmable and configurable through multi-line graphics display.
- Upload firmware and download statistics through a USB connection.
- Performance and error logs provide data to maximize profitability.
- Senses product consistency or temperature to customize for a wide variety of mixes.
- Standby and sleep modes conserve energy and automatically defrost product, maintaining small ice crystals and delivering a superior mouthfeel.



Every machine includes Stoelting's White Glove Service. One call does it all – customer service, technical service, parts or warranty information, installation, startup, sales, on-site service dispatch and much more. Available 24 hours a day, seven days a week year-round.

ITEMS

E131X	F131X
Air-Cooled	
E131-302I2	F131X-302I2
E131X-314I2	F131X-302I2-GP
E131X-314I2-WF	F131X-302I2-WF
	F131X-314I2
	F131X-314I2-WF
Water-Cooled	
E131X-102I2	F131X-102I2

ACCESSORIES & OPTIONS

- 2204542** Hopper Lock Kit.
- 4177350** FS2 - Floor Stand 22" x 24" x 31".
- 4183513** FSS2 - Floor Stand 22" x 24" x 26".
- 2202408** FS4 - Floor Stand 24-1/4" x 22-1/4" x 18-3/4".
- 521030** Standalone Mix In Blender with Foot Switch, 200-240V.
- 521035** Standalone Mix In Blender with Mounted Speed Control, 200-240V.
- 2177877** Side Mounted Spinner Kit (kit must be installed by a qualified service technician).

FEATURES

- NSF approved food-grade plastic blades provide quiet operation and superior durability.
- Simplified design for quick assembly after cleaning.
- Clear door displays circulating product for merchandising appeal.
- Highly efficient auger design gently folds the entire contents of the freezing cylinder, delivering a thick, smooth, and creamy product.
- Efficient freezing cylinder and auger design delivers a consistent uniform product with small ice crystals and a quick recovery time.
- Self-closing spigot eliminates waste and ensures precise portion control.
- Compact counter-top design saves valuable counter space.
- Long-wearing parts offer lower preventative maintenance costs.

Continuous research leads to ongoing product improvements; therefore, these specifications are subject to change without notice and should not be used as installation specifications.

Approvals	Date

E131X, F131X GRAVITY FED TWIN TWIST COUNTERTOP MACHINES

DIMENSIONS

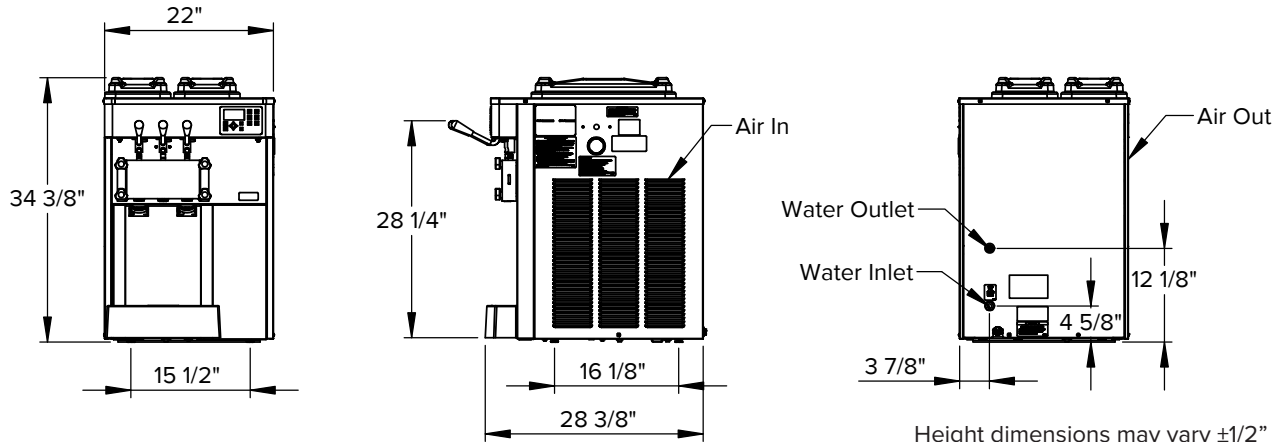

Height dimensions may vary $\pm 1/2$ " due to adjustable legs

GENERAL SPECIFICATIONS

Model	Freezing Cylinder				Hopper Capacity gallon (L)	Drive Motor (hp)	Weight lb (kg)	Crated Weight lb (kg)
	Capacity gallon (L)	Compressor						
		Btu/hr	Refrigerant	Charge (oz)				
E131X	Two 0.65 (2.5)	8,000	R-448A	A/C: 29 W/C: 23	Two 3 (11.4)	Two 3/4	370 (167.8)	450 (204.1)
F131X	Two 0.85 (3.2)	12,000	R-448A	A/C: 35 W/C: 27	Two 3 (11.4)	Two 3/4	385 (174.6)	450 (204.1)

- Indoor use only.
- Maximum ambient temperature: 100°F (37.8°C).
- Requires a dedicated electrical circuit.
- Air cooled units require: 3" (7.6 cm) air space on both sides.
- Water cooled units require: 3/8" N.P.T. water and drain fittings. Maximum water pressure of 130 psi. Minimum water flow rate of 3 GPM. Ideal EWT of 50°-70°F.
- Details on CAD Revit Symbols Libraries are available on www.stoelting.kclcad.com website.

ITEM NUMBER SPECIFICATIONS

Model Number	Cooling	Phase	Volts	Hz	Running Amps	Cord with Plug (Included)	Type "G" Cord End	WiFi Module
E131X-102I2	Water	1	220-240	50	12	NA	—	—
E131X-302I2	Air	1	220-240	50	12	NA	—	—
E131X-314I2	Air	3	380-415	50	12	NA	—	—
E131X-314I2-WF	Air	3	380-415	50	12	NA	—	✓
F131X-102I2	Water	1	220-240	50	11	NA	—	—
F131X-302I2	Air	1	220-240	50	16	NA	—	—
F131X-302I2-GP	Air	1	220-240	50	16	✓	✓	—
F131X-302I2-WF	Air	1	220-240	50	16	NA	—	✓
F131X-314I2	Air	3	380-415	50	12	NA	—	—
F131X-314I2-WF	Air	3	380-415	50	12	NA	—	✓



Service Information
 800-319-9549 (U.S. Toll Free)
 920-894-2293 (Outside the U.S.)
www.stoeltingfoodservice.com
www.vollrath.com