

STRIDENT⁺ BATTERIES

GP12-55 12V 55Ah(20hr)



The rechargeable batteries are lead-lead dioxide systems. The dilute sulfuric acid electrolyte is absorbed by separators and plates and thus immobilized. Should the battery be accidentally overcharged producing hydrogen and oxygen, special one-way valves allow the gases to escape thus avoiding excessive pressure build-up. Otherwise, the battery is completely sealed and is, therefore maintenance-free and leak proof. Batteries should be used in an upright position only.

Battery Construction

Component	Positive Plate	Negative Plate	Container	Cover	Safety Value	Terminal	Separator	Electrolyte
Raw Material	Lead Dioxide	Lead	ABS	ABS	Rubber	Copper	Fibreglass	Sulfuric Acid

General Features

- Positive and negative plates in lead-calcium-tin alloy.
- Stable Quality & High Reliability
- Sealed Construction.
- Long Service Life.
- Maintenance-Free Operation
- Low Pressure Venting System
- Low Self Discharge
- U.L. Component Recognition
- Six Month Shelf Life at 20°C
- Design life 10 Years

Performance Characteristics

- Nominal Voltage: 12V
- Number of Cells: 6
- Nominal Capacity 77°F (25°C)
 - 10 Hour Rate (10.0A, 10.8V): 55Ah
 - 5 Hour Rate (17.5A, 10.5V): 46.15Ah
 - 1 Hour Rate (66.2A, 9.60V): 35.1Ah
- Internal Resistance
 - Fully Charged Battery 77°F (25°C) 5.8m Ohms
- Self-Discharge
 - 3% of capacity declined per month at 20° (average)
- Operating Temperature Range
 - Discharge: -20~60°C
 - Charge: -10~60°C
 - Storage: -20~60°C
- Max. Discharge Current 77°F (25°C): 550A (5s)
- Short Circuit Current: 1400A
- Charge methods: Constant Voltage Charge 77°F (25°C)
 - Cycle use: 2.30-2.35VPC
 - Maximum charging current: 16.5A
 - Temperature Compensation: -30mV/°C
- Standby use: 2.23-2.27VPC
 - Temperature compensation: -20mV/°C

Dimensions and Weight

Length (mm/inch)	229/9.01
Width (mm/inch)	138/5.43
Height (mm/inch)	208/8.18
Total Height (mm/inch)	213/8.13
Approx. Weight (kg/lbs)	18.5/40.8

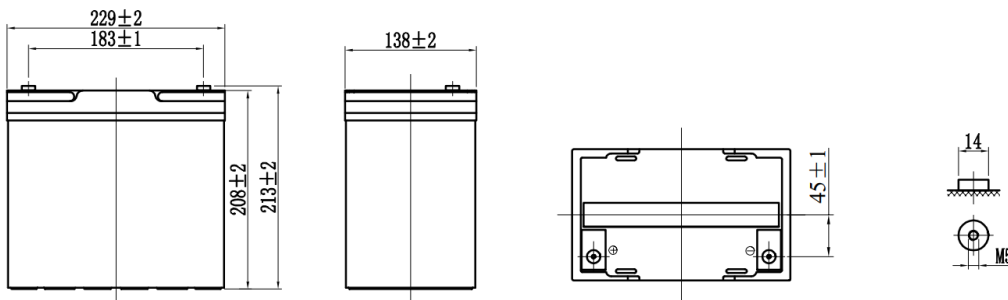

STRIDENT
INNOVATIONS

www.strident.uk.com



Strident

50 Turbine Way, Eco Tech Business & Innovation Park, Swaffham, Norfolk, PE37 7XD
Tel: +44 (0)1362 300102 | Fax: +44 (0)1362 300103 | Email: sales@strident.uk.com

STRIDENT⁺ BATTERIES

GP12-55 12V 55Ah(20hr)

Discharge Data

Discharge Constant Current (Amperes at 77°F/25°C)								
End Point Volts/Cell	10min	15min	30min	1h	3h	5h	10h	20h
1.60V	129	99.4	59.2	35.1	14.6	9.82	5.70	2.97
1.65V	124	95.4	57.4	34.2	14.2	9.57	5.65	2.96
1.70V	115	90.6	55.6	33.3	13.9	9.40	5.60	2.95
1.75V	106	85.8	53.8	32.5	13.6	9.23	5.55	2.93
1.80V	99.8	79.5	51.9	31.7	13.3	9.06	5.50	2.90

The above characteristics data are average values obtained with three charge/discharge cycles, not the minimum values.

Discharge Constant Power (watts at 77°F/25°C)								
End Point Volts/Cell	10min	15min	30min	45min	1h	2h	3h	5h
1.60V	238	185	111	85.3	68.9	41.1	29.1	18.8
1.65V	225	177	109	84.0	67.3	40.2	28.5	18.6
1.70V	213	169	107	82.3	65.8	39.4	27.9	18.2
1.75V	200	162	105	80.5	64.3	38.4	27.3	18.0
1.80V	186	154	104	78.4	62.6	37.4	26.7	17.9

The above characteristics data are average values obtained with three charge/discharge cycles, not the minimum values.

Strident



50 Turbine Way, Eco Tech Business & Innovation Park, Swaffham, Norfolk, PE37 7XD
Tel: +44 (0)1362 300102 | Fax: +44 (0)1362 300103 | Email: sales@strident.uk.com

STRIDENT[™]
INNOVATIONS

www.strident.uk.com

STRIDENT⁺

BATTERIES

GP12-55 12V 55Ah(20hr)

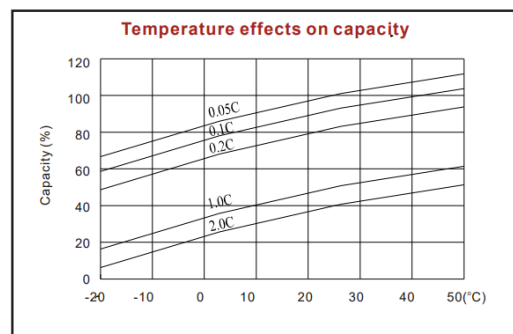
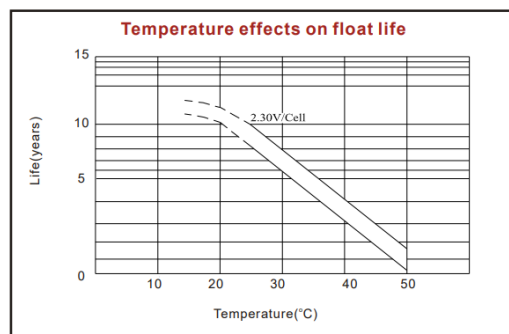
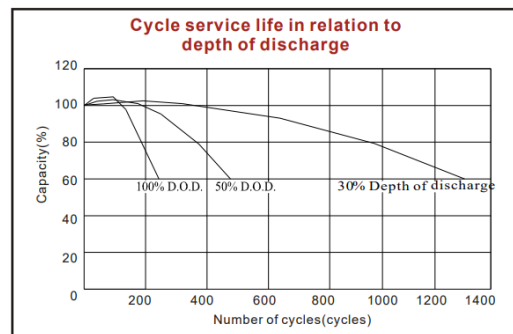
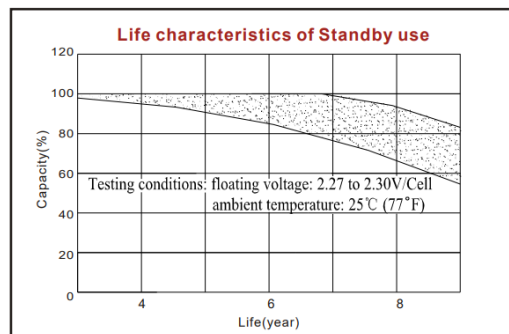
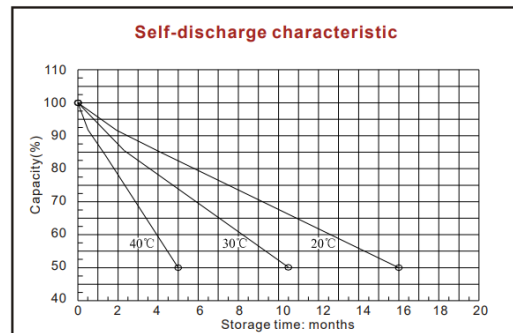
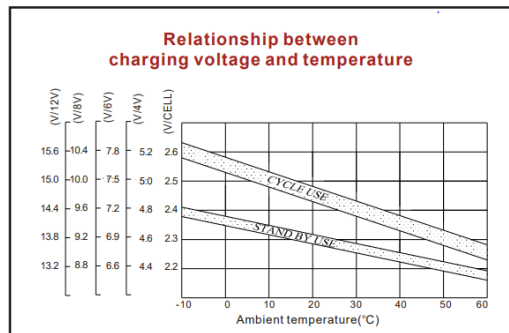
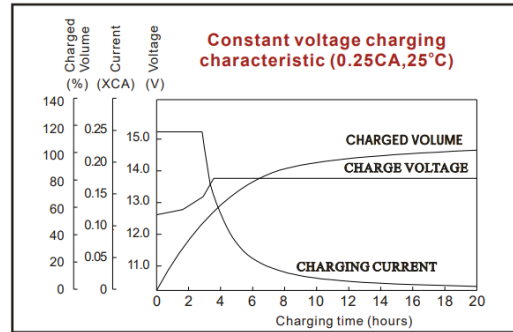
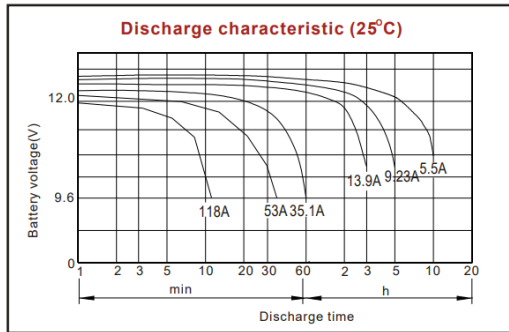

STRIDENT
INNOVATIONS

www.strident.uk.com



Strident

50 Turbine Way, Eco Tech Business & Innovation Park, Swaffham, Norfolk, PE37 7XD
Tel: +44 (0)1362 300102 | Fax: +44 (0)1362 300103 | Email: sales@strident.uk.com