



Project:

Item Number:

Quantity:

F231-2X GRAVITY FED TWIN TWIST FLOOR MODEL WITH LARGE CAPACITY HOPPER



DESCRIPTION

Stoelting’s Gravity Soft Serve Freezer dispenses two single flavors, or combines them in a twin twist. The F231-2X has 66% larger storage capacity than the standard F231. Each hopper can hold up to five gallons of mix.

This freezer is ideal in self-serve and buffet-style restaurants or any location seeking the convenience of less frequent hopper refills.

 Every machine includes Stoelting’s White Glove Service. One call does it all – customer service, technical service, parts or warranty information, installation, startup, sales, on-site service dispatch and much more. Available 24 hours a day, seven days a week year-round.

ITEMS

- F231-3812-2X** Air-Cooled, Single Phase. Standard Carburetors
- F231-30912-2X** Air-Cooled, Three Phase. Standard Carburetors

ACCESSORIES

- 2204806** Adjustable Carburetor - allows for multiple mix types (sorbet, gelato, ice cream).

FEATURES

- NSF approved food grade plastic blades provide quiet operation and superior durability.
- Simplified design for quick assembly after cleaning.
- Adjust the dispense rate to meet your requirements.
- Clear door displays circulating product for merchandising appeal.
- Efficient freezing cylinder and auger design delivers a consistent uniform product with small ice crystals and a quick recovery time.
- Highly efficient auger design gently folds the entire contents of the freezing cylinder, delivering a thick, smooth, and creamy product.
- Self-closing spigot eliminates waste and ensures precise portion control.
- Long-wearing parts offer lower preventative maintenance costs.
- Organized hopper covers have compartments for all parts in the freezing cylinder. The hopper covers help with parts identification and prevent loss of parts.

IntelliTec™ Control

- Programmable and configurable through multi-line graphics display.
- Upload firmware and download statistics through a USB connection.
- Performance and error logs provide data to maximize profitability.
- Senses product consistency or temperature to customize for a wide variety of mixes.
- Standby and sleep modes conserve energy and automatically defrost product, maintaining small ice crystals and delivering a superior mouthfeel.

ADA Compliant Handles

- Flat handles 48” from ground.

Continuous research leads to ongoing product improvements; therefore, these specifications are subject to change without notice and should not be used as installation specifications.

Approvals	Date

F231-2X GRAVITY FED TWIN TWIST FLOOR MODEL WITH LARGE CAPACITY HOPPER

DIMENSIONS

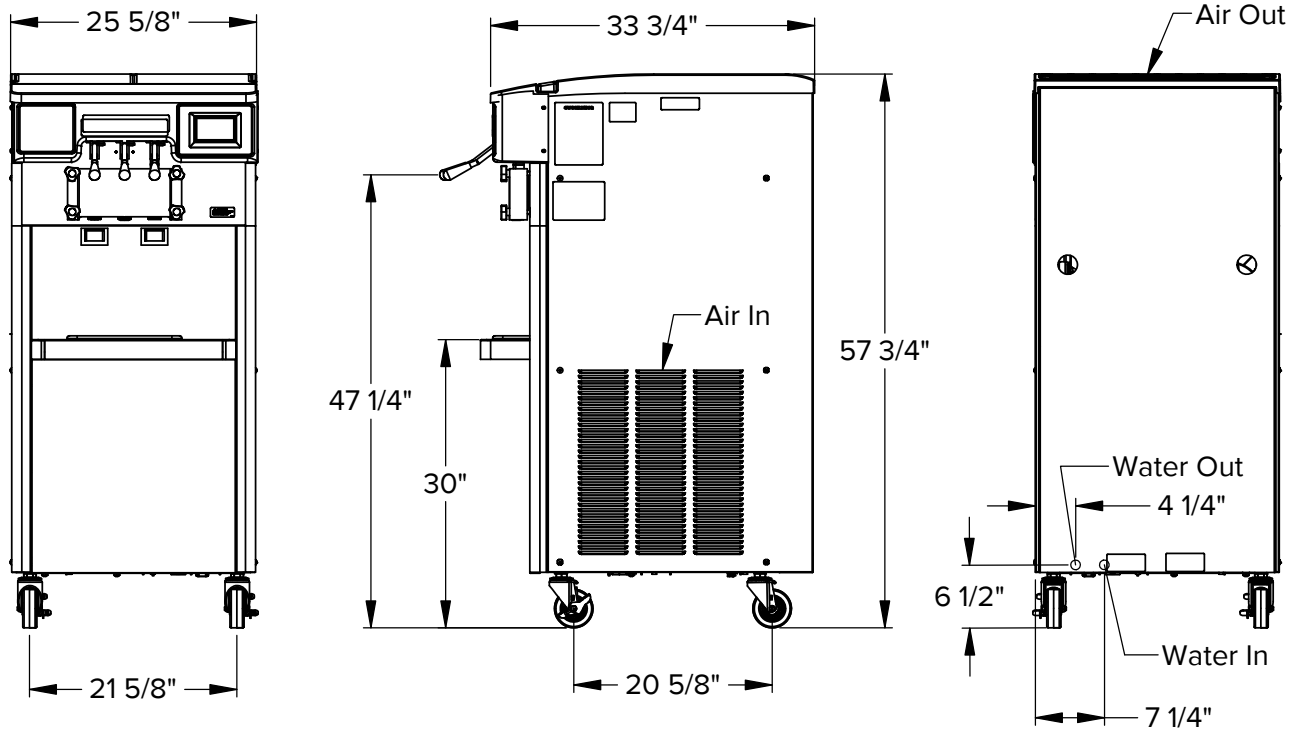

GENERAL SPECIFICATIONS

Freezing Cylinder				Hopper				Drive Motor (hp)	Weight lb (kg)	Crated Weight lb (kg)
Capacity gallon (L)	Compressor			Capacity gallon (L)	Compressor					
	Btu/hr	Refrigerant	Charge (oz)		Btu/hr	Refrigerant	Charge (oz)			
Two 0.85 (3.2)	12,000	R-448A	42	Two 5 (18.9)	1,300	R-134a	8	Two 3/4	520 (235.9)	610 (276.7)

- Indoor use only.
- Maximum ambient temperature: 100°F (37.8°C).
- Requires a dedicated electrical circuit.
- Air cooled units require: 3" (7.6 cm) air space on both sides.
- Details on CAD Revit Symbols Libraries are available on stoelting.klccad.com

ITEM NUMBER SPECIFICATIONS

Model Number	Cooling	Phase	Volts	Hz	Running Amps	Cord with Plug (Included)	Carburetor
F231-3812-2X	Air	1	208-240	60	13.52	NEMA 6-20P	Standard
F231-30912-2X	Air	3	208-240	60	11.52	NEMA L15-20P	Standard



Service Information
 800-319-9549 (U.S. Toll Free)
 920-894-2293 (Outside the U.S.)
www.stoeltingfoodservice.com
www.vollrath.com