

**MODEL: IRR-AGB23_2 / IRR-AGB23_49
 IRR-AGB23_49_BT**

**REACH-IN:
 Top Mounted Reach-in Refrigerators and Freezers (Solid Door)**



GENERAL FEATURES

- ✓ **Higher energy efficiency.** R290 refrigerant with electric fans, LED lighting and evaporative tray without electric resistances.
- ✓ **Sanitation.** Our units feature a hygienic design with rounded corners that have a large radius, making them easy to clean. Additionally, the shelves and runners inside the display can be quickly removed for thorough interior cleaning. Each unit is equipped with a trap at the bottom to facilitate cleaning.
- ✓ **Doors.** Self-closing door system features a permanent pressure mechanism, ensuring a secure closure every time. Additionally, a convenient 'stay open' feature engages when the door remains open at 95 degrees or beyond. Our doors also include triple chamber door gaskets that are easy to remove and snap in, ensuring an effective seal. Plus, for added flexibility, our doors are field reversible, allowing for easy installation and use in a variety of settings.
- ✓ **Control System.** Our temperature management system offers unparalleled precision, allowing for highly accurate temperature settings. With greater flexibility in adjusting temperature ranges, our system can be tailored to meet the unique needs of each end user. This ensures optimal performance and maximum satisfaction with every use.
- ✓ **Lighting.** LED lighting in the canopy reduces the energy consumption by 80% to 90% compared to a traditional bulb, better light quality.
- ✓ **100% Tested.** All condenser units are 100% tested, in helium chambers for refrigerant leak detections.
- ✓ **Certified.** Audited and Certified by INTERTEK for compliance with UL 471 and NSF 7.



Revision:02 Date: 04/11/2023 IRR_AGB23_2 / IRR-AGB23_49_R / IRR-AGB23_49BT

ETL LISTED TO UL471 STANDARD AND SANITATION CLASSIFIED TO NSF7 – WE RESERVE THE RIGHT TO CHANGE SPECIFICATIONS WITHOUT PRIOR NOTICE

**MODEL: IRR-AGB23_2 / IRR-AGB23_49
 IRR-AGB23_49_BT**

**REACH-IN:
 Top Mounted Reach-in Refrigerators and Freezers (Solid Door)**

STANDARD FEATURES

➤ **Exterior**

- AISI 304 Stainless Steel.

➤ **Interior**

- AISI 430 Stainless Steel with a 304-interior bottom.
- Sealed interior floors and rounded cabinet corners.
- LED lighting.
- Internal drain trap for easy cleaning.

➤ **Door**

- Polyurethane insulated door.
- Self – closing door with stay open feature.
- Stainless Steel heavy-duty hinges.
- Triple chamber snap in door gaskets for easy removal and cleaning.
- Field reversible door (hardware needed).
- Heated door frame to avoid ice accumulation. (Freezers only)
- Door locks.
- Full-height door opening: 23" x 53" (584x1346 mm).

➤ **Insulation**

- CFC- Free polyurethane insulation, entire cabinet structure is foamed-in using a high-density polyurethane insulation.
- Low GWP & Zero ODP effect.

➤ **Casters**

- 4" Diameter casters already installed.
- Locks provided on front set.

➤ **Shelving**

- (3) Three plastic coated wire shelves single door with stainless steel tray slides included.
- Dimensions WxD: 20-7/8" x 25-5/8" (530 x 650 mm).
- Tray slides are compatible with 18" x 26" (457 x 660 mm) and 12" x 20" (305x660 mm) sheet pans.

➤ **Refrigeration**

- Digital temperature controller with automatic defrost system.
- Hinged control panel, easily removable.
- **Compact refrigeration system Monoblock, INFRIBLOCK®.**
- Energy-saving non-electric condensate pan.
- Evaporator coil coated with anti-corrosion material 100% Polyester.
- Expansion valve.
- **Refrigeration capacity:**
IRR-AGB23_2 - 1511Btu/h(14°F) / **443W(-10°C).**
IRR-AGB23 - 1511Btu/h(14°F) / **443W(-10°C).**
IRR-AGB49 - 2119 Btu/h(14°F) / **621W(-10°C).**
IRR-AGB23BT - 2716Btu/h(-22°F) / **796W(-30°C).**
IRR-AGB49BT - 4081Btu/h(14°F) / **1.196W(-30°C).**

➤ **Electrical**

- Cord and NEMA 5-15 plug.
- Electrical connection is 115V / 1ph / 60 Hz.



➤ **ETL Listed to UL471 Standard and Sanitation classified to NSF7.**

OPTIONAL FEATURES

- ✓ Stainless Steel wire shelf.
- ✓ Additional slide kits.
- ✓ Set of 6" legs, height adjustable from 5" to 8".
- ✓ Electrical connection is 230 V / 1 ph / 50 Hz (Plug type and consumption varies).

**MODEL: IRR-AGB23_2 / IRR-AGB23_49
IRR-AGB23_49_BT**

**REACH-IN:
Top Mounted Reach-in Refrigerators and Freezers (Solid Door)**

MODELS	Dimensions (inches) (mm)			Doors	Shelves	Ref	Ref. Weight (Lbs.) (gr.)	Temperature Range (°F) (°C)	Capacity (Cu.Ft.) (L)	Cond. Unit. H.P.	Case Amps 115V	Crated weight (Lbs.) (kg.)
	W	D	H									
IRR-AGB23_2	27 (687)	31-1/4 (797)	84 (2.125)	2	3	R290	0,32 (110)	-10°F/0°F (-23°C/-17°C)	23 (652)	1/4	3,49	400 (181)
IRR-AGB23	27 (687)	31-1/4 (797)	84 (2.125)	1	3	R290	0,32 (145)	33°F/38°F (0°C/4°C)	23 (652)	1/4	3,49	400 (181)
IRR-AGB49	54-1/2 (1.384)	31-3/8 (797)	83-5/32 (2.125)	2	6	R290	0,33 (150)	33°F/38°F (0°C/4°C)	49 (1.387)	1/3	4,81	507 (230)
IRR-AGB23BT	27 (687)	31-3/8 (797)	83-5/32 (2.125)	1	3	R290	0,33 (150)	-5°F/0°F (-18°C)	23 (652)	3/4	7,99	421 (191)
IRR-AGB49BT	54-1/2 (1.384)	31-3/8 (797)	83-5/32 (2.125)	2	6	R290	0,33 (150)	-5°F/0°F (-18°C)	49 (1.387)	1-1/4	11,71	553 (251)

PLAN VIEW

ELEVATION

RIGHT VIEW

PLANT VIEW

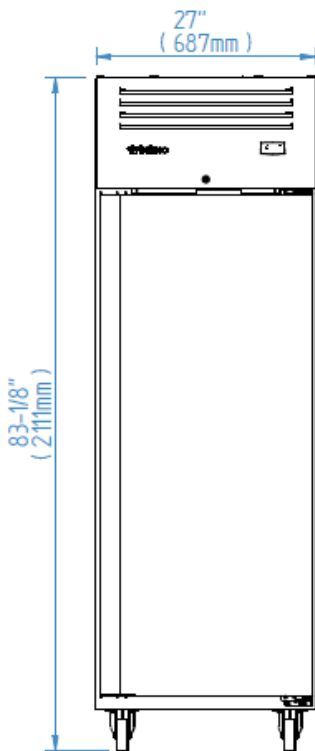

**IRR-AGB23
IRR-AGB23BT**

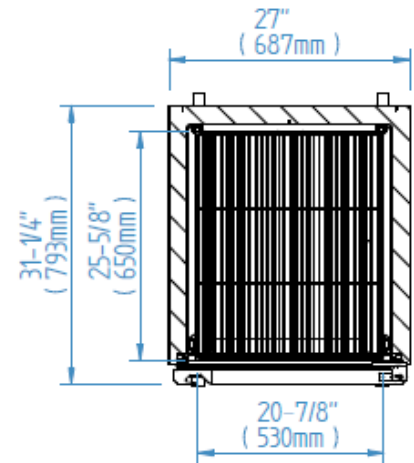
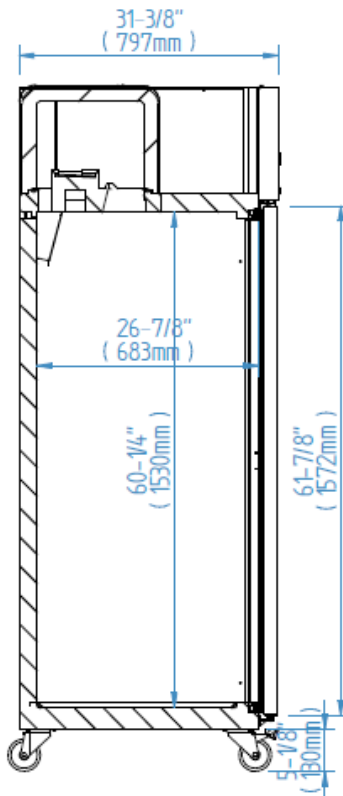

Revision:02 Date: 04/11/2023 IRR-AGB23/49 & IRR-AGB23BT/49BT

ETL LISTED TO UL471 STANDARD AND SANITATION CLASSIFIED TO NSF7 – WE RESERVE THE RIGHT TO CHANGE SPECIFICATIONS WITHOUT PRIOR NOTICE



INFRICO-North America Corporate División
1409NW 84th Avenue, Doral FL 33126
(305) 777 9599 ext.700 / f (305) 777 9598
Toll Free 855-340-4637

www.infrico.us
sales@infrico.com

**MODEL: IRR-AGB23_2 / IRR-AGB23_49
 IRR-AGB23_49_BT**

**REACH-IN:
 Top Mounted Reach-in Refrigerators and Freezers (Solid Door)**

ELEVATION RIGHT VIEW PLANT VIEW

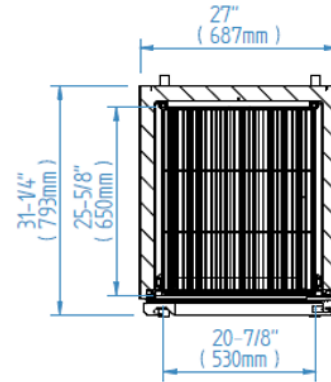
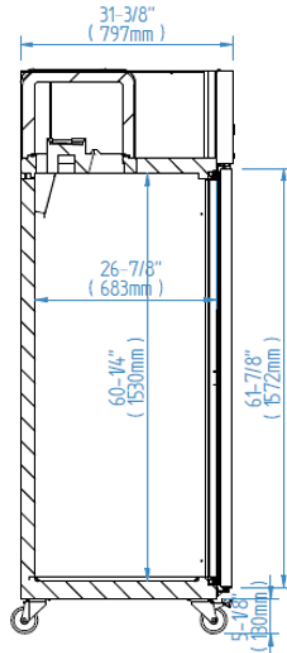
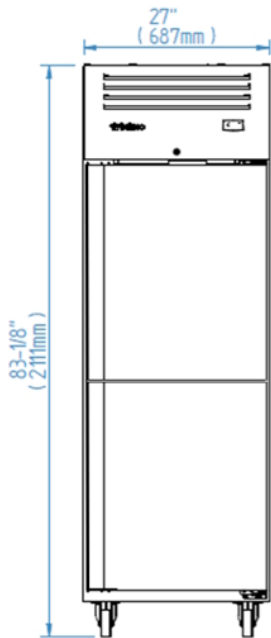

IRR-AGB23_2

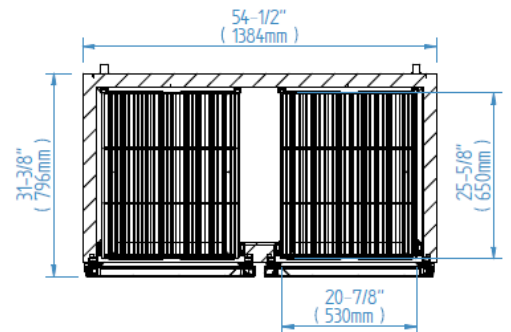
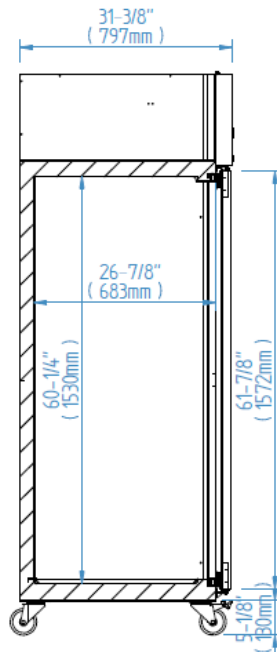
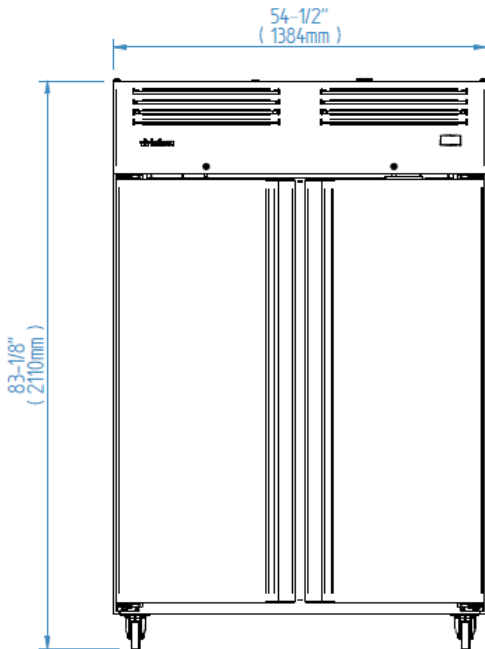

**IRR-AGB49
 IRR-AGB49BT**

Revision:02 Date: 04/11/2023 IRR-AGB23/49 & IRR-AGB23BT/49BT

ETL LISTED TO UL471 STANDARD AND SANITATION CLASSIFIED TO NSF7 – WE RESERVE THE RIGHT TO CHANGE SPECIFICATIONS WITHOUT PRIOR NOTICE



INFRICO-North America Corporate División
 1409NW 84th Avenue, Doral FL 33126
 (305) 777 9599 ext.700 / f (305) 777 9598
 Toll Free 855-340-4637

www.infrico.us
sales@infrico.com