

MODEL: IRR-AGB23CR / IRR-AGB49CR **REACH-IN:**
Top Mounted Reach-in Split glass door refrigerators

GENERAL FEATURES



- ✓ **Higher energy efficiency.** R290 refrigerant with electric fans, LED lighting and evaporative tray without electric resistances.
- ✓ **Sanitation.** Our units feature a hygienic design with rounded corners that have a large radius, making them easy to clean. Additionally, the shelves and runners inside the display can be quickly removed for thorough interior cleaning. Each unit is equipped with a trap at the bottom to facilitate cleaning.
- ✓ **Doors.** Self-closing door system features a permanent pressure mechanism, ensuring a secure closure every time. Additionally, a convenient 'stay open' feature engages when the door remains open at 95 degrees or beyond. Our doors also include triple chamber door gaskets that are easy to remove and snap in, ensuring an effective seal. Plus, for added flexibility, our doors are field reversible, allowing for easy installation and use in a variety of settings.
- ✓ **Control System.** Our temperature management system offers unparalleled precision, allowing for highly accurate temperature settings. With greater flexibility in adjusting temperature ranges, our system can be tailored to meet the unique needs of each end user. This ensures optimal performance and maximum satisfaction with every use.
- ✓ **Lighting.** LED lighting in the canopy and cabinet sides reduces the energy consumption by 80% to 90% compared to a traditional bulb, better light quality.
- ✓ **100% Tested.** All condenser units are 100% tested, in helium chambers for refrigerant leak detections.
- ✓ **Certified.** Audited and Certified by INTERTEK for compliance with UL 471 and NSF 7.



Revision:02 Date: 04/12/2023 IRR-AGB23CR/49CR

ETL LISTED TO UL471 STANDARD AND SANITATION CLASSIFIED TO NSF7 – WE RESERVE THE RIGHT TO CHANGE SPECIFICATIONS WITHOUT PRIOR NOTICE

MODEL: IRR-AGB23CR / IRR-AGB49CR **REACH-IN:**
Top Mounted Reach-in Split glass door refrigerators

STANDARD FEATURES

> **Exterior**

- AISI 304 Stainless Steel.

> **Interior**

- AISI 430 Stainless Steel with a 304-interior bottom.
- Sealed interior floors and rounded cabinet corners.
- LED lighting.
- Internal drain trap for easy cleaning.

> **Door**

- Self – closing door with stay open feature.
- Stainless Steel heavy-duty hinges.
- Triple chamber snap in door gaskets for easy removal and cleaning.
- Field reversible door (hardware needed).
- Heated door frame to avoid ice accumulation. (Freezers only)
- Door locks.
- Full-height door opening: 23" x 53" (584x1346 mm).

> **Insulation**

- CFC- Free polyurethane insulation, entire cabinet structure is foamed-in using a high-density polyurethane insulation.
- Low GWP & Zero ODP effect.

> **Casters**

- 4" Diameter casters already installed.
- Locks provided on front set.

> **Shelving**

- (3) Three plastic coated wire shelves single door with stainless steel tray slides included.
- (6) Six plastic coated wire shelves single door with stainless steel tray slides included.
- Dimensions WxD: 20-7/8" x 25-5/8" (530 x 650 mm).
- Tray slides are compatible with 18" x 26" (457 x 660 mm) and 12" x 20" (305x660 mm) sheet pans.

> **Refrigeration**

- Digital temperature controller with automatic defrost system.
- Hinged control panel, easily removable.
- **Compact refrigeration system Monoblock, INFRIBLOCK®.**
- Energy-saving non-electric condensate pan.
- Evaporator coil coated with anti-corrosion material 100% Polyester.
- Expansion valve.
- **Refrigeration capacity:**
 IRR-AGB23CR – 2.119 Btu/h(14°F)/621W(-10°C).
 IRR-AGB49CR – 2.119 Btu/h(14°F)/621W(-10°C).

> **Electrical**

- Cord and NEMA 5-P plug,
- Electrical connection is 115V / 1ph / 60 Hz.



> **ETL Listed to UL471 Standard and Sanitation classified to NSF7.**

OPTIONAL FEATURES

- ✓ Stainless Steel wire shelf.
- ✓ Additional slide kits.
- ✓ Set of 6" legs, height adjustable from 5" to 8".
- ✓ Electrical connection is 230 V / 1 ph / 50 Hz (Plug type and consumption varies).

MODEL: IRR-AGB23CR / IRR-AGB49CR **REACH-IN:**
Top Mounted Reach-in Split glass door refrigerators

MODELS	Dimensions (Inches) (mm)			Doors	Shelves	Ref.	Ref. Weight (Lbs.) (gr.)	Temperature Range (°F) (°C)	Capacity (Cu.Ft.) (L)	Cond. Unit. H.P.	Case Amps 115V	Grated weight (Lbs.) (kg.)
	W	D	H									
IRR-AGB23CR	27 (687)	31-1/4 (794)	84 (2.125)	1	4	R290	0,25 (115)	33°F/38°F (0°C/4°C)	23 (652)	1/3	5,03	400 (181)
IRR-AGB49CR	54-1/2 (1.384)	31-1/4 (794)	84 (2.125)	2	8	R290	0,31 (140)	33°F/38°F (0°C/4°C)	49 (1.387)	1/3	5,21	650 (295)

PLAN VIEW

ELEVATION

RIGHT VIEW

PLANT VIEW

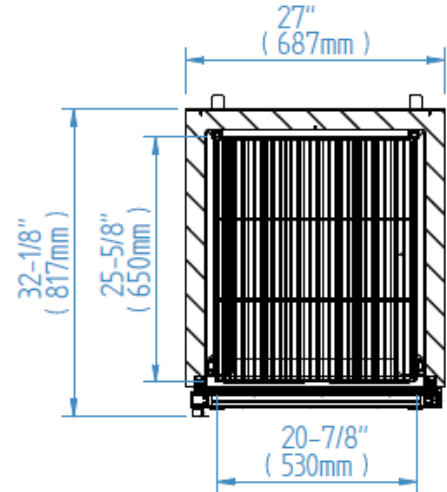
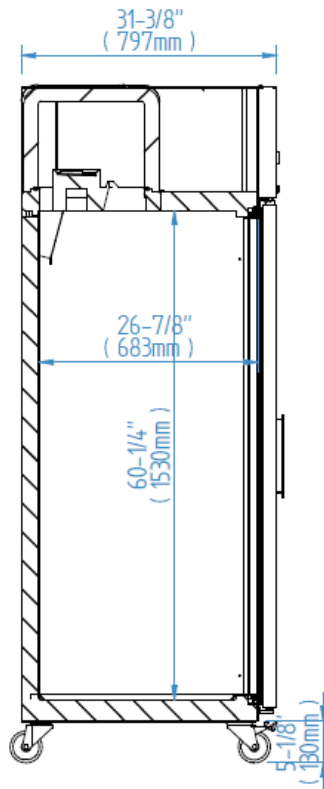
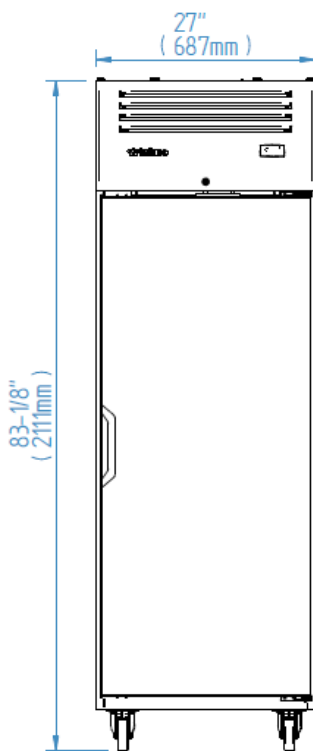

IRR-AGB23CR

Revision:02 Date: 04/12/2023 IRR-AGB23CR/49CR

ETL LISTED TO UL471 STANDARD AND SANITATION CLASSIFIED TO NSF7 – WE RESERVE THE RIGHT TO CHANGE SPECIFICATIONS WITHOUT PRIOR NOTICE

MODEL: IRR-AGB23CR / IRR-AGB49CR **REACH-IN:**
Top Mounted Reach-in Split glass door refrigerators

ELEVATION **RIGHT VIEW** **PLANT VIEW**

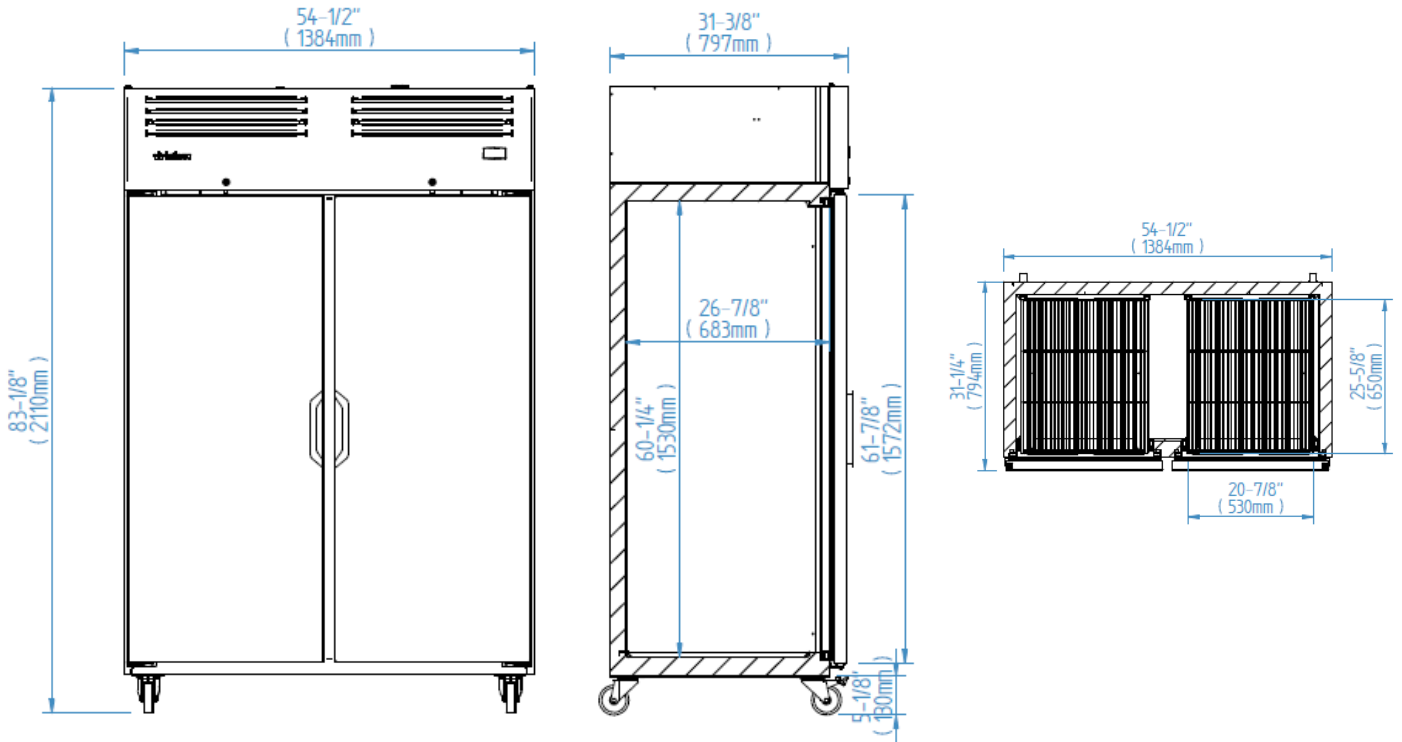

IRR-AGB49CR

Revision:02 Date: 04/12/2023 IRR-AGB23CR/49CR

ETL LISTED TO UL471 STANDARD AND SANITATION CLASSIFIED TO NSF7 – WE RESERVE THE RIGHT TO CHANGE SPECIFICATIONS WITHOUT PRIOR NOTICE