

**MODEL: IUC-MR93GTCOMBO**
**UNDERCOUNTER:  
Granite top pizza prep tables.**

### General Strengths

- ✓ **Higher energy efficiency.** R290 refrigerant with electronic fans and evaporative tray without electric heaters.
- ✓ **Sanitation.** The interior cabinet is built with rounded corners (extensive radius for easy cleaning). Quick ability to take off shelves and slides for interior cleaning. Each cabinet has a drain at the bottom of the unit. When cleaning the unit make sure the drain hose is routed to a floor drain.
- ✓ **Doors & Drawers.** Self-closing door system with permanent pressure. Stay open feature included when door remains open after 95 degrees. All doors include triple chamber door gaskets, easy to remove and snap in.
- ✓ **Control systems.** Greater ability for the adjustment of temperature range as per the end user's requirements.
- ✓ **100% Tested.** All condenser units are 100% tested, in helium chambers for refrigerant leak detections.
- ✓ **Certified.** Audited and Certified by INTERTEK for compliance with UL 471 and NSF 7. AENOR audited and certified by internationally recognized firm. ISO 9001:2015 (Quality); ISO 14001:2015 (Environmental); OSHAS 18001:2007 (Prevention and Worker Safety)



| MODEL               |        | Dimensions (inches) (mm) |               |                | Nº Doors | Nº Shelves | Ref.  | Ref. Weight (Lbs.) (gr.) | Temp. Range (°F) (°C)  | Capacity (Cu. Ft.) (L) | Cond. Unit. H.P. | Case Amps 115 V. | Crated Weight (Lbs.) (Kg.) |
|---------------------|--------|--------------------------|---------------|----------------|----------|------------|-------|--------------------------|------------------------|------------------------|------------------|------------------|----------------------------|
|                     |        | W                        | D             | H              |          |            |       |                          |                        |                        |                  |                  |                            |
| IUC-MR93GT<br>Combo | Tables | 93-1/4<br>2370           | 32-5/8<br>830 | 59-3/8<br>1508 | 3        | 4          | R290  | 0.26<br>120              | 35°F/41°F<br>+2°C/+5°C | 27<br>765              | 1/2              | 6.2              | 1260                       |
|                     | VIPS   | 90-9/16<br>2300          | 16-1/4<br>413 | 17-3/4<br>450  | -        | -          | R134a | 0.59<br>270              | 39°F/41°F<br>+3°C/+5°C | 2.86<br>81             | 1/6              | 1.82             | 572                        |

FTL LISTED TO UL471 STANDARD AND SANITATION CLASSIFIED TO NSF7 - WE RESERVE THE RIGHT TO CHANGE SPECIFICATIONS WITHOUT PRIOR NOTICE

**MODEL: IUC-MR93GTCOMBO**
**UNDERCOUNTER:  
Granite top pizza prep tables.**
**STANDARD FEATURES**
**➤ Exterior**

- AISI 304 Stainless Steel Top,
- AISI 430 Stainless Steel.

**➤ Interior**

- AISI 430 Stainless Steel,
- Internal drain plugs for easy cleaning,
- Sealed interior floors and rounded cabinet corners.

**➤ Doors**

- Polyurethane insulated doors,
- Self-closing doors with stay open feature,
- Stainless Steel heavy-duty hinges,
- Triple chamber snap in door gaskets for easy removal and cleaning,
- Door locks,
- Door opening: WxH= 22-7/8"x20-5/8" (580x525 mm).

**➤ Insulation**

- CFC-Free polyurethane insulation, entire cabinet structure is foamed-in using a high-density polyurethane insulation,
- Low GWP & Zero ODP effect.

**OPTIONAL FEATURES**

- ✓ Set of 6" legs, height adjustable from 5" to 8",
- ✓ Stainless Steel wire shelves,
- ✓ Additional slide kits,
- ✓ Drawer kit,
- ✓ Electrical connection is: 230 V / 1ph / 50 Hz (plug type varies).

**➤ Casters**

- 4" diameter casters,
- Locks provided on front set.

**➤ Shelving**

- (2) Plastic coated wire shelves per section,
- Guides and shelves easy to take off for cleaning,
- Dimensions WxD: 20-7/8"x25-5/8" (GN 2/1) (530x650 mm),
- Compatible with 18"x26" (457x660 mm) sheet pans.

**➤ Refrigeration**

- Digital temperature controller with automatic defrost system,
- Energy-saving non-electric condensate Pan,
- Forced air refrigeration system,
- Extractable condensing unit for easy service,
- Evaporator coil coated with anti-corrosion material 100% Polyester,
- Electronic fans,
- Refrigeration capacity: 2375 Btu/h (14°F) / 696 W (-10°C) (Table) + 478 Btu/h (14°F) / 140 W (-10°C) (VIP).

**➤ Electrical**

- Cord and NEMA 5-15P plug.
- Electrical connection is 115V / 1ph / 60 Hz.
- 15 AMP breakers required,

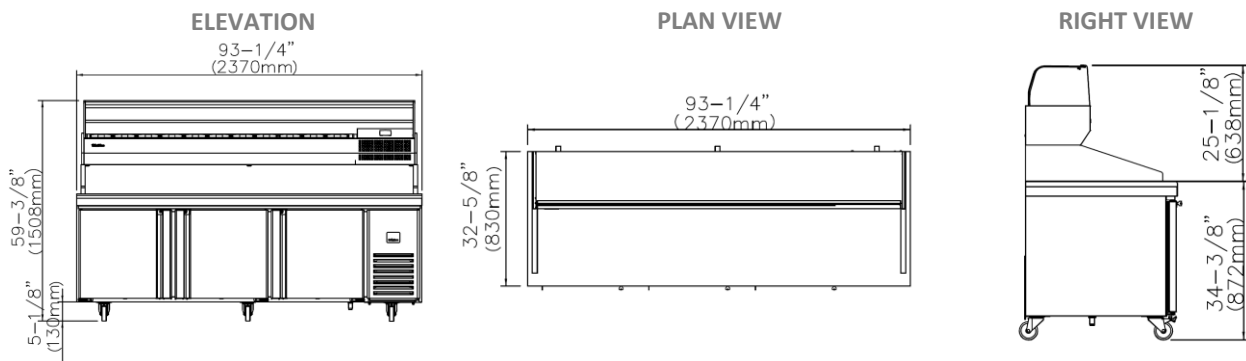
**➤ ETL Listed to UL471 Standard and Sanitation classified to NSF7.**
**PLAN VIEW**

ETL LISTED TO UL471 STANDARD AND SANITATION CLASSIFIED TO NSF7 - WE RESERVE THE RIGHT TO CHANGE SPECIFICATIONS WITHOUT PRIOR NOTICE