

Aurora Undercounter Freezers, Stainless Steel

ITEM: 59053
MODEL: FR-CN-0686E-HC

59092
FR-CN-1529E-HC



59053
FR-CN-0686E-HC



59092
FR-CN-1529E-HC

The perfect solution to add cold storage space for frozen products and ingredients conveniently within reach.

This undercounter freezer is perfect for cold food storage operations while saving space. Slide it under a counter or work table to utilize its space for storing chilled items. Its durable stainless steel construction is designed to endure frequent use, and its user-friendly controls reduce the time spent adjusting and monitoring settings for peak performance. Additionally, it uses Hydro-carbon R290 refrigerant, which is environmentally friendly and more efficient.

FEATURES:

- Stainless steel interior and exterior
- Refrigeration system keeps food at safe
- Self-closing doors with 90-degree stay-open feature
- Adjustable heavy-duty PVC coated shelves
- Digital control system makes it easy to adjust temperature set point and defrost frequency
- Hydro-carbon R290 refrigerant, which is environmentally friendly and more efficient

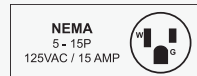
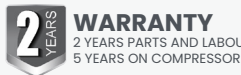

TECHNICAL SPECIFICATION

Features	27" wide with 6.3 cu.ft. (177 L) Capacity	60" wide with 15 cu. ft. (425 L) Capacity
Item	59053	59092
Model	FR-CN-0686E-HC	FR-CN-1529E-HC
Capacity	6.3 cu.ft. (177 L)	15 cu. ft. (425 L)
Number of Doors	1 Swing Door - Solid Door	2 Swing Doors - Solid Doors
Number of Shelves	1	2
Shelf Capacity (kg/pc)	44 lb. (20 kg.)	88lb. (40kg.)
Shelf Material	Plastic Coated Steel	
Number of Casters	Yes (4)	
Self-closing Door	Yes	
Power	1/6 HP	345 W
Amps	1.9 A	4.5 A
Electrical	110-120V / 60Hz / 1Ph	
Temperature Controller	Digital Display	
Temperature Range	-18 to -22°C (-0 to -8°F)	-18 to -22°C (-0 to -8°F)
Refrigerant:	R290	
Insulation Material	Cyclopentane	
Cooling System	Ventilated	
Defrosting	Automatic	
Interior Dimensions (WDH)	22.2" x 22.8" x 23.5" (565 x 580 x 597 mm)	55.6" x 19.84" x 23.5" (1413 x 504 x 597 mm)
Net Weight	169lb. (77 kg.)	254 lb. (115 kg.)
Net Dimensions (WDH)	27" x 29.5" x 35.2" (685 x 750 x 895 mm)	60.2"x 29.5" x 38.8" (1529 x 750 x 985 mm)
Gross Weight	220 lb. (100 kg.)	324 lb. (147 kg.)
Gross Dimensions (WDH)	30" x 33 " x 39" (770 x 830 x 980 mm)	74" x 32" x 38" (1600 x 820 x 970 mm)
Plug Type	NEMA 5-15P	

* This equipment is intended for indoor environment using where ambient temperature do not exceed 24°C(75°F) & 55% relative humidity

TECHNICAL DRAWING

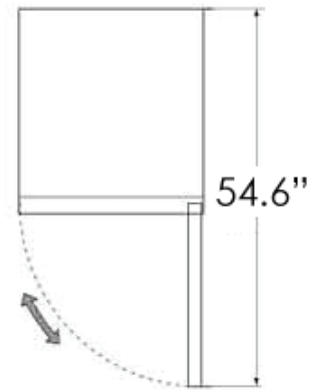
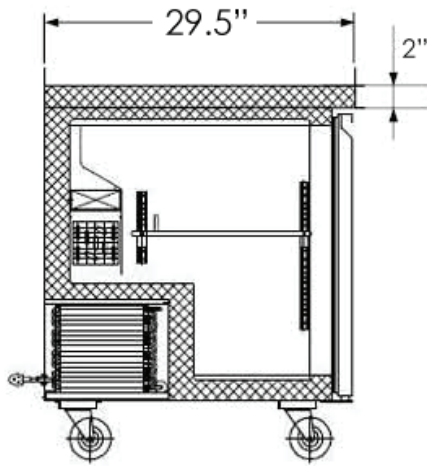
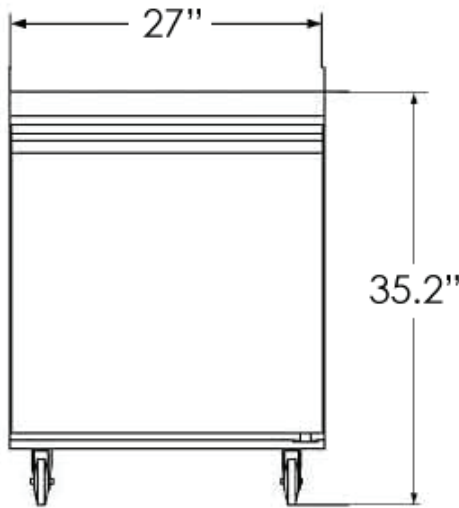

59053
FR-CN-0686E-HC

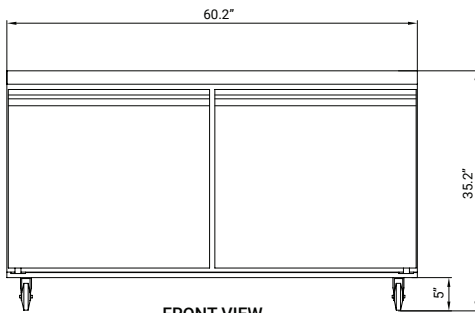

FRONT VIEW

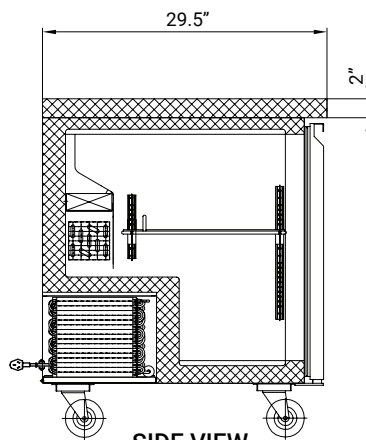

SIDE VIEW

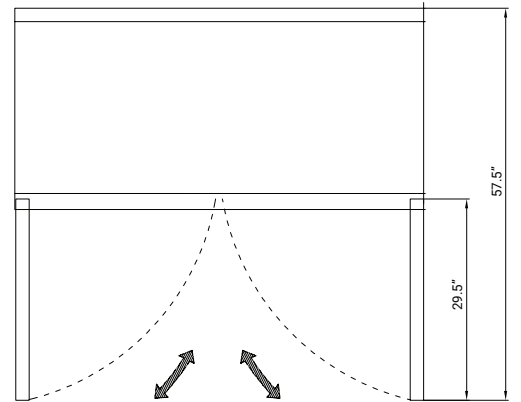

TOP VIEW

59092
FR-CN-1529E-HC