

# Operating Instructions

## **Fronius Primo GEN24**

3.0 SC / 3.0 Plus SC / 3.6 SC / 3.6 Plus SC

4.0 SC / 4.0 Plus SC / 4.6 SC / 4.6 Plus SC

5.0 SC / 5.0 Plus SC / 6.0 SC / 6.0 Plus SC

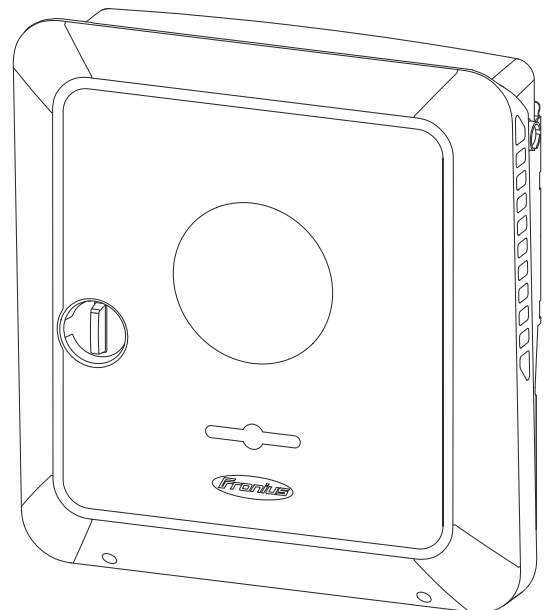



# Table of contents

Safety rules.....	9
Explanation of safety instructions.....	9
How information is presented in the document.....	9
Safety.....	10
Safety instructions and important information.....	10
Environmental conditions.....	11
Target group.....	11
Electromagnetic fields.....	11
Data on noise emission values.....	12
EMC measures.....	12
Backup power.....	12
Data security.....	13
Copyright.....	13
Ground conductor.....	13
<b>General information</b> .....	<b>15</b>
Fronius Primo GEN24 SC / Fronius Primo GEN24 Plus SC.....	17
Device concept.....	17
Function overview.....	17
Fronius UP.....	18
Scope of supply.....	18
Intended use.....	18
Thermal concept.....	19
Fronius Solar.web.....	19
Local communication.....	19
Different operating modes.....	21
Operating modes – Explanation of symbols.....	21
Operating mode – Inverter with battery.....	22
Operating mode – Inverter with battery and several Smart Meters.....	22
Operating mode – Inverter with battery, AC-coupled to another inverter.....	22
Operating mode – Inverter with battery and backup power function.....	22
Operating mode – Inverter with battery, Ohmpilot, and backup power function.....	23
Operating mode – Inverter with battery, another inverter, and backup power function.....	23
Energy flow direction of the inverter.....	24
Operating states (only for battery systems).....	24
Energy-saving mode.....	25
General.....	25
Switch-off conditions.....	25
Switch-on conditions.....	25
Special case.....	25
Indication of energy saving mode.....	26
Suitable batteries.....	27
General.....	27
Restrictions during operation.....	27
Fronius batteries.....	27
BYD batteries.....	28
LG FLEX.....	29
Manual system start.....	31
Requirements.....	31
Notification of system shutdown.....	31
Manual battery start after system shutdown.....	31
Starting backup power operation after a system shutdown.....	31
Protection of people and equipment.....	32
Central grid and system protection.....	32
WSD (wired shutdown).....	32
RCMU.....	32
Insulation monitoring.....	32
AFCI - Arc Fault Circuit Interrupter (Arc Guard).....	32

Safe state.....	33
Operating controls and connections.....	34
Connection area.....	34
Connection area divider.....	35
Ground electrode terminal.....	35
DC disconnect.....	36
Data communication area.....	36
Button functions and LED status indicator.....	37
Schematic internal wiring of IOs.....	39
<b>Backup power variant - PV Point (OP)</b> .....	<b>41</b>
General.....	43
Explanatory note - PV Point/PV Point Comfort.....	43
PV Point (OP).....	43
PV Point Comfort.....	44
<b>Backup power variant - Full Backup</b> .....	<b>45</b>
General.....	47
Prerequisites for backup power mode.....	47
Transitioning from grid power feed operation to backup power mode.....	47
Transitioning from backup power mode to grid power feed operation.....	47
Backup power and energy saving mode.....	47
Automatic switch to backup power incl. backup power circuits and 1-pin separation, e.g., Australia.....	49
Functions.....	49
Transitioning from grid power feed operation to backup power mode.....	49
Transitioning from backup power mode to grid power feed operation.....	49
Automatic switch to backup power all-pin separation, e.g., Germany, France, UK, Spain.....	50
Functions.....	50
Transitioning from grid power feed operation to backup power mode.....	50
Transitioning from backup power mode to grid power feed operation.....	51
Automatic switch to backup power all-pin separation, Italy.....	52
Functions.....	52
Transitioning from grid power feed operation to backup power mode.....	52
Transitioning from backup power mode to grid power feed operation.....	53
Manual switch to backup power 1-pin separation, e.g., Australia / 2-pin separation, e.g., Germany.....	54
Functions.....	54
Transition from grid power feed operation to backup power mode.....	54
Transitioning from backup power mode to grid power feed operation.....	55
<b>Installation</b> .....	<b>57</b>
General.....	59
Quick-fastener system.....	59
Information on the device.....	59
System component compatibility.....	60
Installation location and position.....	61
Choosing the location of the inverter.....	61
Choosing the location of third-party batteries.....	62
Installation position of the inverter.....	63
Installing the mounting bracket and attaching the inverter.....	65
Selecting the mounting material.....	65
Properties of the mounting bracket.....	65
Do not deform the mounting bracket.....	65
Fitting the mounting bracket to a wall.....	65
Installing the mounting bracket on a mast or beam.....	66
Attaching the mounting bracket to mounting rails.....	67
Attaching the inverter to the mounting bracket.....	67
Requirements for connecting the inverter.....	68
Different cable types.....	68
Permissible cables for the electrical connection.....	68

Permitted cables for the data communication connection.....	69
Cable diameter of the AC cable.....	70
Cable diameter of DC cable.....	70
Maximum alternating current fuse protection.....	70
Connecting the inverter to the public grid (AC side).....	72
Safety.....	72
Connecting the inverter to the public grid (AC side).....	72
Connecting solar module strings to the inverter.....	76
General information about PV modules.....	76
Safety.....	76
PV Generator, general.....	77
Module array configuration 3 - 6 kW.....	77
Connecting solar module strings to the inverter.....	78
Connecting the battery to the inverter.....	82
Safety.....	82
Connecting the battery on the DC side.....	82
Connecting the LG FLEX ground conductor.....	84
Connecting backup power - PV Point (OP).....	86
Safety.....	86
Installation.....	86
Testing backup power mode.....	90
Connecting backup power - Full Backup.....	91
Safety.....	91
Automatic switch to backup power 1-pin single separation, e.g., Australia.....	91
Automatic switch to backup power 2-pole single disconnection e.g., Germany, France, UK, Spain.....	92
Automatic switch to backup power 2-pole double disconnection with ext. grid and system protection e.g., Italy.....	93
Manual switch to backup power 1-pole disconnection e.g., Australia / 2-pole disconnection e.g., Germany.....	94
Testing backup power mode.....	95
Connecting the data communication cables.....	97
Modbus participants.....	97
Routing data communication cables.....	97
Connecting the battery communication cable.....	99
Terminating resistors.....	100
Installing the WSD (wired shutdown).....	102
Closing and commissioning the inverter.....	103
Closing the inverter's connection area/housing cover, and commissioning.....	103
Starting the inverter for the first time.....	104
Installation with the app.....	104
Installation with the browser.....	105
De-energizing the inverter and switching it back on.....	107
De-energizing the inverter and switching it back on.....	107

**Settings – User interface of the inverter** **109**

User settings.....	111
User login.....	111
Selecting languages.....	111
Device configuration.....	112
Components.....	112
Functions and I/Os.....	113
Demand Response Modes (DRM).....	115
Inverter.....	115
Energy management.....	119
Permitted maximum battery charge from the public grid.....	119
Battery management.....	119
Examples - Time-dependent battery control.....	120
Permitted battery control regulations.....	123
PV power reduction.....	124
Load management.....	125

Self-consumption optimization.....	125
System.....	127
General.....	127
Update.....	127
Setup wizard.....	127
Restoring factory settings.....	127
Event log.....	127
Information.....	127
License Manager.....	127
Licensing.....	128
Support.....	128
Communication.....	130
Network.....	130
Modbus.....	131
Cloud control.....	133
Solar API.....	133
Fronius Solar.web.....	133
Safety and grid requirements.....	135
Country setup.....	135
Requesting inverter codes in Solar.SOS.....	135
Absolute Generation Limit.....	136
Import limitation.....	136
Export limitation.....	136
Dynamic feed-in limit with multiple inverters.....	138
I/O Power Management.....	140
Connection diagram - 4 relays.....	142
I/O power management settings - 4 relays.....	143
Connection diagram - 3 relays.....	143
I/O power management settings - 3 relays.....	145
Connection diagram - 2 relays.....	145
I/O power management settings - 2 relays.....	147
Connection diagram - 1 relay.....	147
I/O power management settings - 1 relay.....	149
Connecting the ripple control receiver with several inverters.....	149
Autotest (CEI 0-21).....	150
<b>Options</b> .....	<b>153</b>
Surge protection device (SPD).....	155
General.....	155
Safety.....	155
Scope of supply.....	155
De-energizing the inverter.....	156
Installation.....	157
Starting up the inverter.....	163
DC Connector Kit GEN24.....	164
General.....	164
General information about PV modules.....	164
Safety.....	164
Scope of supply.....	165
De-energizing the inverter.....	166
Installation.....	166
Starting up the inverter.....	171
PV Point Comfort.....	172
Safety.....	172
Scope of supply.....	173
De-energizing the inverter.....	173
Installation.....	174
Starting up the inverter.....	180
Configuring the PV Point Comfort.....	180
Testing backup power mode.....	181

<b>Appendix</b>	<b>183</b>
Service, maintenance and disposal .....	185
General.....	185
Cleaning.....	185
Maintenance.....	185
Safety.....	185
Operation in dusty environments .....	185
Disposal.....	186
Warranty provisions .....	188
Fronius manufacturer's warranty.....	188
Components for switching to backup power .....	189
Components for automatic backup power changeover to Full Backup.....	189
Components for manual backup power changeover to Full Backup.....	190
Status codes and remedy.....	191
Display.....	191
Status codes.....	191
Technical data.....	193
Fronius Primo GEN24 3.0 SC / 3.0 Plus SC.....	193
Fronius Primo GEN24 3.6 SC / 3.6 Plus SC.....	197
Fronius Primo GEN24 4.0 SC / 4.0 Plus SC .....	200
Fronius Primo GEN24 4.6 SC / 4.6 Plus SC.....	204
Fronius Primo GEN24 5.0 SC / 5.0 Plus SC.....	208
Fronius Primo GEN24 6.0 SC / 6.0 Plus SC.....	212
WLAN.....	216
Technical data of surge protection device DC SPD type 1+2 GEN24.....	217
Explanation of footnotes.....	217
Integrated DC disconnecter .....	218
<b>System circuit diagrams</b>	<b>219</b>
Fronius Primo GEN24 and Fronius Reserva.....	220
Fronius Primo GEN24 with Fronius Reserva connected in parallel.....	221
Fronius Primo GEN24 and Fronius Reserva Pro .....	222
Fronius Primo GEN24 with Fronius Reserva Pro connected in parallel.....	223
Fronius Primo GEN24 and BYD Battery-Box Premium HV .....	224
Fronius Primo GEN24 with two BYD Battery-Box Premium HV connected in parallel.....	225
Fronius Primo GEN24 with three BYD Battery-Box Premium HV connected in parallel.....	226
Fronius Primo GEN24 and BYD Battery-Box HVS+/HVM+.....	227
Fronius Primo GEN24 with BYD Battery-Box HVS+/HVM+ connected in parallel.....	228
Fronius Primo GEN24 and LG FLEX.....	229
Surge protection device (SPD).....	230
<b>Circuit diagrams—PV Point</b>	<b>231</b>
Emergency power terminal—PV Point (OP).....	232
Circuit diagram - PV Point (OP) Australia .....	233
Backup power terminal - PV Point (OP) with battery only for France.....	234
Backup power terminal - PV Point (OP) manual changeover .....	235
PV Point Comfort.....	236
<b>Circuit diagrams—automatic switch to backup power with Fronius Backup Controller</b>	<b>237</b>
Fronius Backup Controller 1-pin separation, e.g., Australia .....	238
Fronius Backup Controller 2-pin separation, e.g., Germany .....	239
<b>Circuit diagrams—automatic switch to backup power with third-party components</b>	<b>241</b>
Automatic switch to backup power 1-pin single FRT-capable separation .....	242
Automatic switch to backup power 1-pin single separation - e.g., Australia.....	243
Automatic switch to backup power 2-pin single separation - e.g., Germany.....	244
Automatic switch to backup power 2-pin single separation - e.g., France.....	245
Automatic switch to backup power 2-pin single separation - e.g., UK.....	246
Automatic switch to backup power 2-pin single separation - e.g., Spain.....	247

Automatic switch to backup power 2-pin double separation with ext. grid and system protection - e.g., Italy.....	248
Fronius Primo GEN24 with Enwitec Box.....	249
<b>Circuit diagrams—manual switch to backup power with Fronius Backup Switch</b>	<b>251</b>
Manual switch to backup power 1-pin separation, e.g., Australia .....	252
Manual switch to backup power 2-pin separation, e.g., Germany .....	253
<b>Dimensions of the inverter</b>	<b>255</b>
Fronius Primo GEN24 SC / Fronius Primo GEN24 Plus SC.....	256

# Safety rules

---

## Explanation of safety instructions



### **WARNING!**

**Indicates a potentially dangerous situation.**

- ▶ Death or serious injury may result if appropriate precautions are not taken.



### **CAUTION!**

**Indicates a potentially harmful situation.**

- ▶ Minor injury or damage to property may result if appropriate precautions are not taken.

### **NOTE!**

**Indicates a possibility of flawed work results and possible damage to the equipment.**

Please pay special attention when one of the symbols from the "Safety rules" chapter appears in these instructions.

---

## How information is presented in the document

The conventions regarding how information is presented in the document, which are set out below, have been defined in order to increase the readability and comprehensibility of the document.

### **Application notes**

**IMPORTANT!** Indicates application notes and other useful information. It does not indicate a harmful or dangerous situation.

### **Software**

Software functions and elements of a graphical user interface (e.g., buttons, menu items) are highlighted in the text with this **mark up**.

Example: Click **Save**.

### **Instructions for action**

**1** Action steps are displayed with consecutive numbering.

- ✓ *This symbol indicates the result of the action step or the entire instruction.*

## Safety



### CAUTION!

#### **Danger from crushing due to the incorrect handling of attachments and connection parts.**

Injuries to limbs may result.

- ▶ Use the integrated grips when lifting up, putting down, and attaching the inverter.
- ▶ When fitting attachments, ensure that no limbs are located between the attachment and the inverter.
- ▶ Do not hold on to the individual poles on the terminals when locking and unlocking.

## Safety instructions and important information

The device has been manufactured in line with the state of the art and according to recognized safety standards.



### WARNING!

#### **Incorrect operation or misuse**

Serious to fatal injuries to the operator or third parties as well as damage to the device and other property of the operator may result.

- ▶ All persons involved in the commissioning, maintenance, and servicing of the device must be appropriately qualified and have knowledge of working with electrical installations.
- ▶ Read these operating instructions in full and follow them carefully and precisely.
- ▶ The operating instructions must always be kept to hand wherever the device is being used.

#### **IMPORTANT!**

In addition to the operating instructions, observe the following general and local rules:

- Accident prevention
- Fire protection
- Environmental protection

#### **IMPORTANT!**

Labels, warning notices, and safety symbols are located on the device. A description can be found in these operating instructions.

#### **IMPORTANT!**

All safety and danger notices on the device:

- Must be kept in a legible state
- Must not be damaged/marked
- Must not be removed
- Must not be covered, have anything stuck on them, or painted over



### WARNING!

#### Tampered-with and non-functioning protection devices

Serious to fatal injuries as well as damage to the device and other property of the operator may result.

- ▶ Never bypass or disable protection devices.
- ▶ Any protection devices that are not fully functional must be repaired by an authorized specialist before the device is switched on.



### WARNING!

#### Loose, damaged, or under-dimensioned cables

An electric shock can be fatal.

- ▶ Use undamaged, insulated, and adequately dimensioned cables.
- ▶ Fasten the cables according to the specifications in the operating instructions.
- ▶ Loose, damaged, or under-dimensioned cables must be repaired or replaced immediately by an authorized specialist.

### NOTE!

#### Installations or modifications to the device

The device may be damaged

- ▶ Do not carry out any alterations, installations, or modifications to the device without first obtaining the manufacturer's permission.
- ▶ Damaged components must be replaced.
- ▶ Only use original spare parts.

---

#### Environmental conditions

Operation or storage of the device outside the stipulated area will be deemed as not in accordance with the intended purpose.

---

#### Target group

This document provides detailed information and instructions to ensure that all users can use the device safely and efficiently.

- The information is intended for the following groups of people:
  - **Technical specialists:** People with appropriate qualifications and fundamental electronic and mechanical knowledge, who are responsible for the installation, operation, and maintenance of the device.
  - **End users:** People that use the device in daily operation and want to understand its basic functions.
- Regardless of any qualifications, only perform the activities listed in this document.
- All persons involved in the commissioning, maintenance, and servicing of the device must be appropriately qualified and have knowledge of working with electrical installations.
- The definition of professional qualifications and their applicability are subject to national law.

---

#### Electromagnetic fields

During operation, due to the high electrical voltages and currents, local electromagnetic fields (EMF) occur in the environment around the inverter and the Fronius system components as well as in the area of the PV modules including the supply lines.

In the case of exposure to humans, the required limit values are observed when the products are used in line with the intended use and the recommended distance of at least 20 cm is observed.

If these limit values are complied with, according to current scientific knowledge, no health-endangering effects from EMF exposure are to be expected. If wearers of prostheses (implants, metal parts in and on the body) as well as active physical aids (pacemakers, insulin pumps, hearing aids, etc.) are in the vicinity of components of the PV system, they must consult with the responsible doctor regarding possible health risks.

---

**Data on noise emission values**

The sound pressure level of the inverter is indicated in the [Technical data](#).

The cooling of the device takes place via an electronic temperature control system at the lowest possible noise level and depends on the power used, ambient temperature, and the soiling level of the device, etc.

It is not possible to provide a workplace-related emission value for this device, because the actual sound pressure level is heavily influenced by the installation situation, the power quality, the surrounding walls, and the properties of the room in general.

---

**EMC measures**

In certain cases, even though a device complies with the standard limit values for emissions, it may affect the application area for which it was designed (e.g., when there is equipment that is susceptible to interference at the same location or if the site where the device is installed is close to either radio or television receivers). If this is the case, the operator is obliged to take action to rectify the situation.

---

**Backup power**

This system has backup power functions, which enable a replacement power supply to be established in the event of a failure of the public grid.

Where an automatic backup power supply is installed, a [backup power warning notice](https://www.fronius.com/en/search-page) (https://www.fronius.com/en/search-page, item number: 42,0409,0275) must be fitted on the electrical distributor.

Maintenance and installation work in the home network requires both disconnection on the utility side and deactivation of the replacement power mode by opening the integrated DC disconnect on the inverter.

The function of the residual current devices for the backup power supply must be checked at regular intervals (according to the manufacturer's instructions), but at least twice a year.

A description on how to perform the test operation can be found in the [backup power checklist](https://www.fronius.com/en/search-page) (https://www.fronius.com/en/search-page, item number: 42,0426,0365).

Depending on the insolation conditions and the battery state of charge, the backup power supply is automatically deactivated and activated. This can cause the backup power supply to unexpectedly return from standby mode. Therefore, installation work can only be performed on the home network when the backup power supply is deactivated.

---

**Influencing factors on the total power in backup power mode:****Reactive power**

Electrical loads with a power factor not equal to 1 also require reactive power in

addition to effective power. The reactive power also loads the inverter. Therefore, to correctly calculate the actual total power, it is not the rated power of the load that is relevant, but the current caused by effective and reactive power.

Devices with a high reactive power are mainly electric motors such as:

- Water pumps
- Circular saws
- Blowers and fans

#### **High starting current**

Electrical loads that need to accelerate a large mass usually require a high starting current. This can be up to 10 times higher than the nominal current. The maximum current of the inverter is available for the starting current. Loads with starting currents that are too high therefore cannot be started/operated, even though the nominal output of the inverter suggests that they can. When dimensioning the backup power circuit, the connected load power and any starting current must also be taken into account.

Devices with high starting currents are, for example:

- Devices with electric motors (e.g., lifting platform, circular saws, planing bench)
- Devices with large transmission ratio and flywheel mass
- Devices with compressors (e.g., compressed air compressors, air conditioning systems)

#### **IMPORTANT!**

Very high starting currents can cause short-term distortion or a drop in output voltage. The simultaneous operation of electronic devices in the same backup power supply system should be avoided.

#### **IMPORTANT!**

The inverter may only be operated within the limits of its technical capabilities. Operation outside of its technical capabilities can cause the inverter to shut down.

---

#### **Data security**

With regard to data security, the user is responsible for:

- backing up any changes made to the factory settings
- saving and storing personal settings.

---

#### **Copyright**

Copyright of these operating instructions remains with the manufacturer.

Text and illustrations were accurate at the time of printing, subject to change. We are grateful for suggestions for improvement and information on any discrepancies in the operating instructions.

---

#### **Ground conductor**

Connection of a point in the device, system, or installation to ground to protect against electric shock in the event of a fault. When installing an inverter from safety class 1 (see [Technical data](#)), a ground conductor connection is required.

When connecting the ground conductor, ensure that it is secured to prevent unintentional disconnection. All of the points listed in the chapter headed [Connecting the inverter to the public grid \(AC side\)](#) on page 72 must be observed. When using cable glands, ensure that the ground conductor is last to be subjected to a load in the event of a failure of the cable gland. The respective national stand-

ards and regulations and requirements for minimum cross-section must be observed when connecting the ground conductor.

# **General information**



# Fronius Primo GEN24 SC / Fronius Primo GEN24 Plus SC

## Device concept

The inverter transforms the direct current generated by the PV modules into alternating current. This alternating current is fed into the public grid and synchronized with the mains voltage in use. Moreover, the solar energy can also be stored in a connected battery for later use.

The inverter is intended for use in grid-connected photovoltaic systems. The inverter has backup power functions and switches to backup power mode if it has been wired accordingly\*.

The inverter automatically monitors the public grid. Whenever conditions in the electric grid are inconsistent with standard conditions (e.g., grid switch-off, interruption), the inverter will immediately stop producing power and interrupt the supply of power into the grid.

The grid is monitored by monitoring the voltage, frequency, and islanding conditions.

After installation and commissioning, the inverter's operation is fully automatic; the inverter draws the maximum possible power from the solar modules. Depending on the operating point, this power is used in the home, stored in a battery\*, or fed into the grid.

As soon as the energy provided by the solar modules is no longer sufficient, the power from the battery is fed into the home network. Depending on the setting, power may also be obtained from the public grid in order to charge the battery\*.

When its temperature gets too high, the inverter automatically reduces the output or charging power, or switches off completely, in order to protect itself. Reasons for the temperature being too high include a high ambient temperature or insufficient heat dissipation (for example, inadequate heat dissipation when installed in switch cabinets).

\* Depending on the device variant, suitable battery, corresponding cabling, settings, and local standards and regulations.

## Function overview

Function	Primo GEN24	Primo GEN24 Plus
Backup power variant - PV Point (OP)	✓	✓
Battery connection*	Available as an option**	✓
Backup power variant - Full Backup	Available as an option**	✓

\* For suitable batteries, see chapter [Suitable batteries](#).

\*\* The functions are optionally available via Fronius UP (see chapter [Fronius UP](#)).

---

## Fronius UP

With Fronius UP\*, optionally available functions can be added to the inverter by the authorized specialist company (see chapter [Function overview](#)).

\* The availability of Fronius UP is country-specific. Click here for further information on [availability](#).

---

## Scope of supply

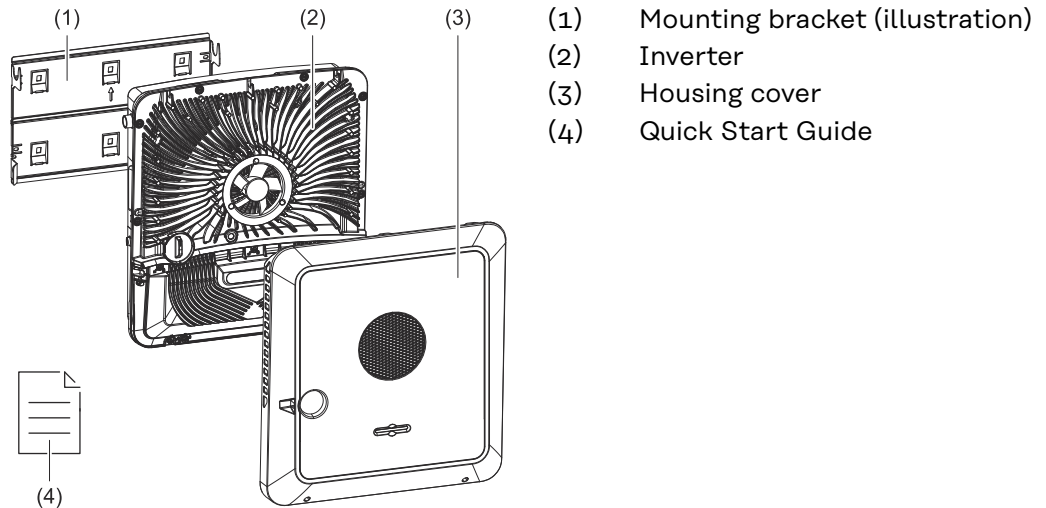

## Intended use

The inverter is designed to convert direct current from PV modules into alternating current and feed this power into the public grid. A backup power mode\* is possible if the wiring is set up accordingly.

Intended use also means:

- Carefully reading and following all the instructions as well as complying with the safety and danger notices in the operating instructions
- Installation in accordance with the chapter headed [Installation](#), from page [57](#)

Follow all grid operator regulations regarding energy fed into the grid and connection methods.

The inverter is a grid-connected inverter with backup power function and is not a stand-alone inverter. The following restrictions in backup power mode must therefore be observed:

- The inverter may be operated for max. 2000 operating hours in backup power mode
- The inverter may be operated for more than 2000 operating hours in backup power mode provided 20% of the grid power feed operating time of the inverter is not exceeded at the time in question

\* Depending on the device variant, suitable battery, corresponding cabling, settings, and local standards and regulations.

## Thermal concept

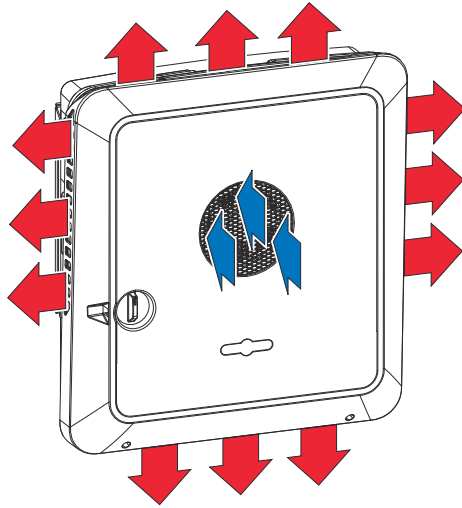

Ambient air is drawn in at the front of the device by the fan and blown out at the sides. The even heat dissipation allows several inverters to be installed next to each another.

### NOTE!

#### **Risk due to insufficient cooling of the inverter.**

This may result in a loss of power in the inverter.

- ▶ Do not block the fan (e.g., with objects that protrude through the touch guard).
- ▶ Do not cover the ventilation slots, even partially.
- ▶ Make sure that the ambient air can always flow through the inverter's ventilation slots unimpeded.

## Fronius Solar.web

System owners and installers can easily monitor and analyze the PV system using Fronius Solar.web or Fronius Solar.web Premium. With the appropriate configuration, the inverter transmits data such as power, yield, load, and energy balance to Fronius Solar.web. More detailed information can be found at [Solar.web - Monitoring & analysis](#).

Configuration is carried out using the Setup wizard; see the chapter headed [Installation with the app](#) on page 104 or [Installation with the browser](#) on page 105.

#### **Requirements for configuration:**

- Internet connection (download: min. 512 kbit/s, upload: min. 256 kbit/s)\*.
- User account at [solarweb.com](http://solarweb.com).
- Completed configuration using the Setup wizard.

\* These specifications do not provide an absolute guarantee of flawless operation. High error rates in the transmission, fluctuating receptions or misfires can have an adverse effect on data transfer. Fronius recommends on-site testing to ensure that the connections meet the minimum requirements.

## Local communication

The inverter can be found via the Multicast DNS (mDNS) protocol. We recommend searching for the inverter using the assigned host name.

The following data can be called up via mDNS:

- NominalPower
- Systemname
- DeviceSerialNumber
- SoftwareBundleVersion

# Different operating modes

## Operating modes – Explanation of symbols

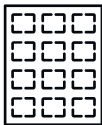

### PV module

generates direct current



### Fronius GEN24 inverter

converts direct current into alternating current and charges the battery (battery charging requires battery support, see chapter [Function overview](#) on page 17). The integrated system monitoring enables the inverter to be integrated into a network by means of WLAN.



### Additional inverter in the system

converts the direct current into alternating current. However, it cannot charge a battery and is not available in backup power mode.



### Battery

is coupled to the inverter on the direct current side and stores electrical energy.



### Fronius Ohmpilot

for using excess energy to heat water.



### Primary meter

records the load curve of the system and makes the measured data available for energy profiling in Fronius Solar.web. The primary meter also regulates the dynamic feed-in control.



### Secondary meter

records the load curve of individual loads (e.g., washing machine, lights, television, heat pump, etc.) in the load branch and makes the measured data available for energy profiling in Fronius Solar.web.



### Loads in the system

are the loads connected in the system.



### Additional loads and producers in the system

which are connected to the system by means of a Smart Meter.



### PV Point

is a non-interruption-free 1-phase backup power circuit, which supplies electrical devices up to a maximum output of 3 kW, provided sufficient power is available from the PV modules or the battery.



### Full Backup

the inverter is prepared for backup power mode. The backup power function must be implemented in the switch cabinet by the electrician performing the installation. The PV system operates in a stand-alone manner in backup power mode.



### Grid

supplies the loads in the system if insufficient power is being generated by the PV modules or supplied by the battery.

**Operating mode  
– Inverter with  
battery**

In order to be able to obtain the highest rate of self-consumption with your photovoltaic system, a battery can be used to store excess energy. The battery is coupled to the inverter on the direct current side. Multiple current conversion is therefore not required, and the efficiency is increased.

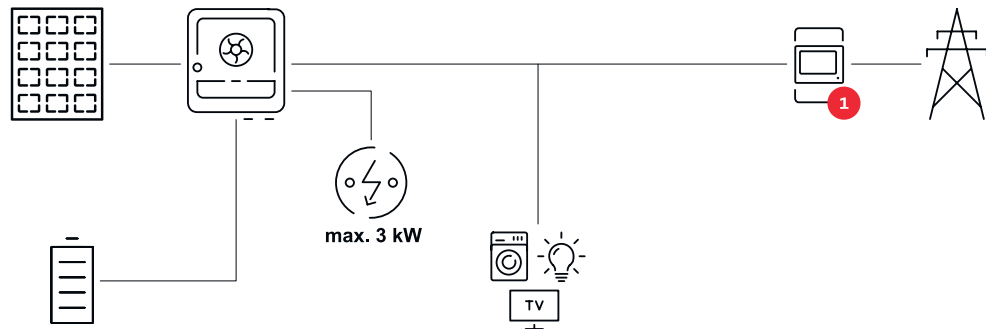

**Operating mode  
– Inverter with  
battery and sev-  
eral Smart  
Meters**

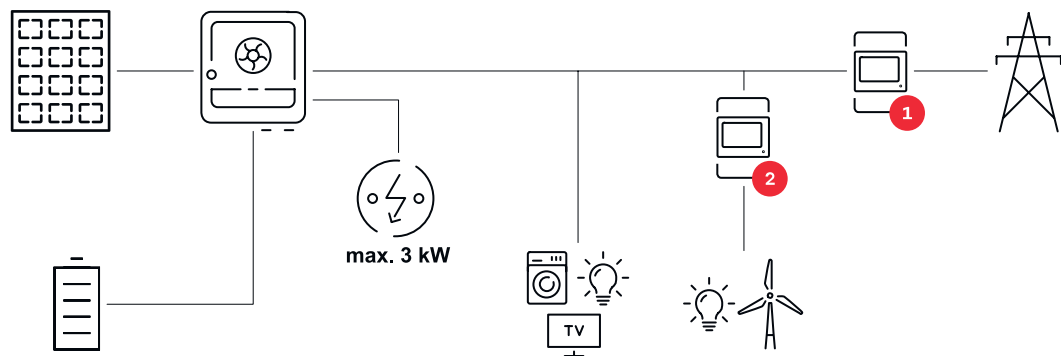

**Operating mode  
– Inverter with  
battery, AC-  
coupled to an-  
other inverter**

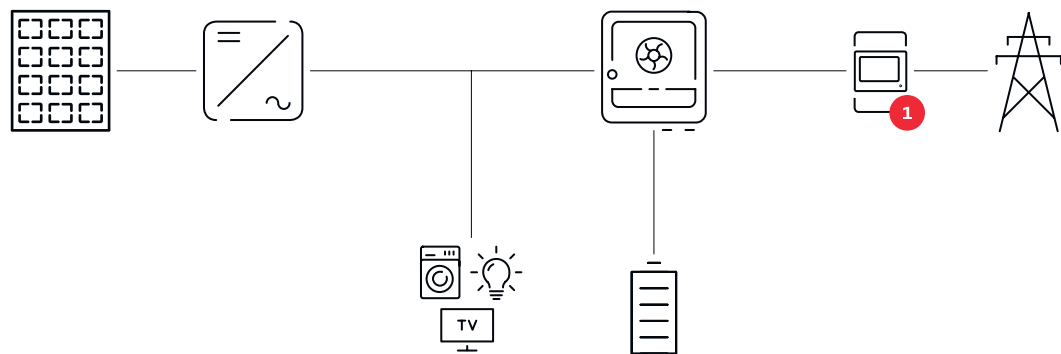

**Operating mode  
– Inverter with  
battery and  
backup power  
function**

**IMPORTANT!**

In backup power mode, an increased nominal frequency is used in order to prevent undesired parallel operation with other power generators.

When the hybrid PV system is equipped with all the available features, the inverter can:

- Supply loads in the house
- Store excess energy in the battery and/or feed it into the grid
- Supply connected loads in the event of a power failure

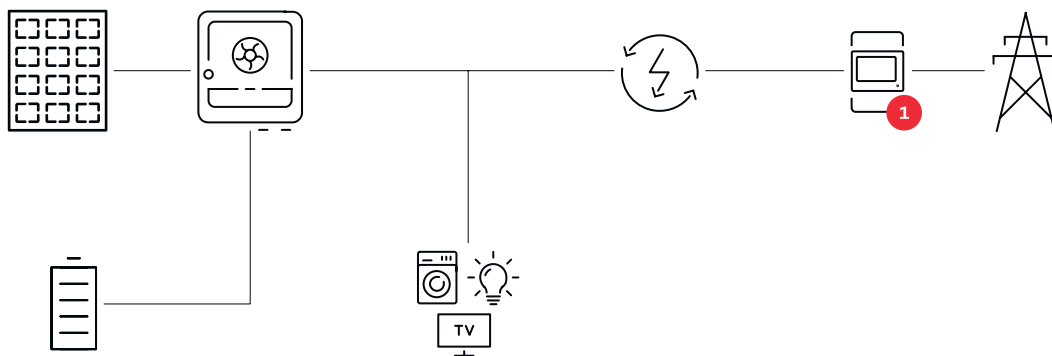

**Operating mode – Inverter with battery, Ohmpilot, and backup power function**

**IMPORTANT!**

In the fully equipped hybrid PV system with a Fronius Ohmpilot, the Ohmpilot cannot be operated in the event of a power failure for regulatory reasons. It is therefore sensible to install the Ohmpilot outside of the backup power branch.

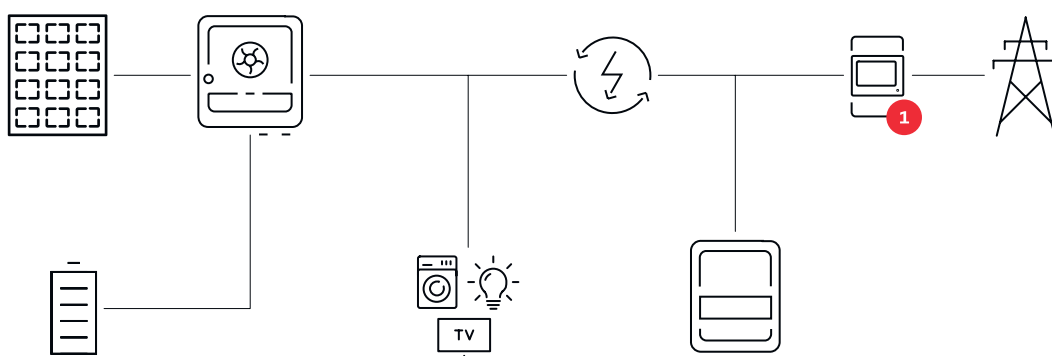

**Operating mode – Inverter with battery, another inverter, and backup power function**

In the hybrid PV system, batteries may only be connected to an inverter with battery support. Batteries cannot be split between multiple inverters with battery support. Depending on the battery manufacturer, however, several batteries can be combined on one inverter.

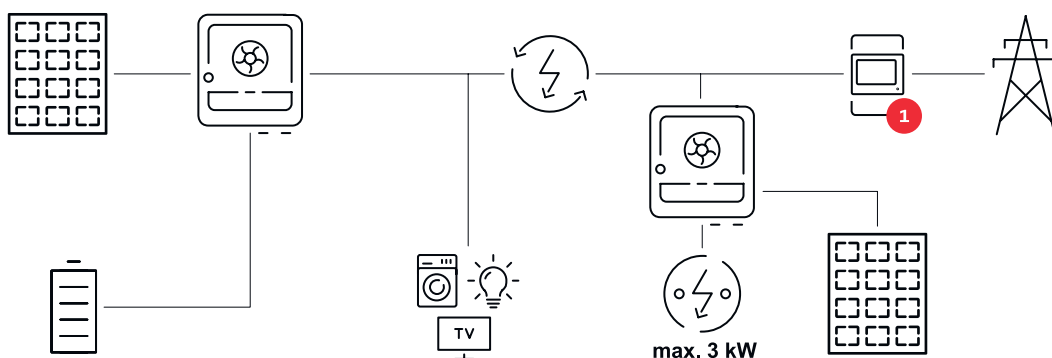

**Energy flow direction of the inverter**

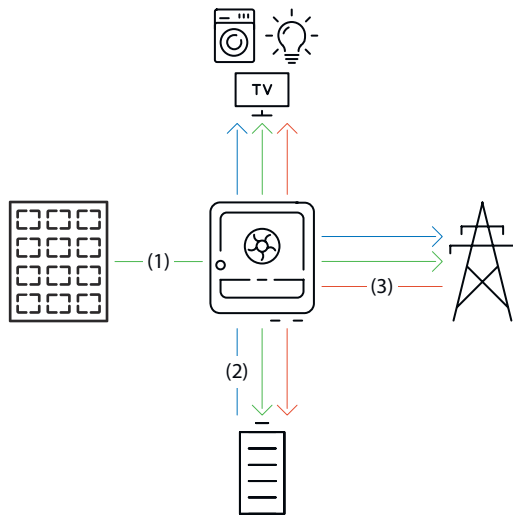

- (1) PV module – inverter – load/ grid/battery
- (2) Battery – inverter – load/grid\*
- (3) Grid – inverter – load/battery\*

\* Charging the battery from the public grid depends on the settings and local standards and regulations.

**Operating states (only for battery systems)**

Battery systems distinguish between different operating states. In each case, the relevant current operating state is displayed on the user interface of the inverter or in Fronius Solar.web.

Operating state	Description
Normal operation	The energy is stored or drawn, as required.
Min. state of charge (SoC) reached	The battery has reached the minimum SoC specified by the manufacturer or the set minimum SoC. The battery cannot be discharged further.
Energy saving mode (standby)	The system has been put into energy-saving mode. Energy saving mode is automatically ended as soon as sufficient surplus power is available again.
Start	The battery system starts from energy-saving mode (standby).
Forced re-charging	The inverter recharges the battery, in order to maintain the SoC specified by the manufacturer or the set minimum SoC (protection against deep discharge).
Calibration charging	The battery system is charged to the SoC of 100% and then discharged to the SoC of 0%. After 1 hour of waiting time at SoC 0%, the calibration charge is stopped and the battery switches to normal operation.
Service mode	The battery system is charged or discharged to the SoC of 30% and the SoC of 30% is maintained until the end of the service mode.
Deactivated	The battery is not active. It has either been deactivated, switched off, or the communication between the battery and the inverter has been interrupted.

# Energy-saving mode

---

## General

Energy saving mode (standby mode) is used to reduce the self-consumption of the system. Both the inverter and the battery automatically switch to energy saving mode under certain conditions.

The inverter switches to energy saving mode if the battery is flat and no PV power is available. Only the inverter's communication with the Fronius Smart Meter and Fronius Solar.web is maintained.

---

## Switch-off conditions

If all the switch-off conditions are met, the battery switches into energy saving mode within ten minutes. This time delay ensures that the inverter can at least be restarted.



≤ min. SoC

The battery state of charge is less than or equal to the input minimum state of charge.



< 100 W

The current charging or discharging power of the battery is less than 100 W.



< 50 W

Less than 50 W is available for charging the battery. The power of feeding into the public grid is at least 50 W less than the power currently required in the home network.

The inverter automatically switches into energy saving mode, following the battery.

---

## Switch-on conditions

If one of the following conditions is met for at least 30 seconds, energy saving mode is ended:

- Energy saving mode is no longer permissible owing to a changed setting on the user interface of the inverter.
  - If dynamic power reduction of 0 is set, or if the system is operating in backup power mode, the power of feeding into the public grid is always less than the required power in the home network.  
There is a separate condition for this case (dynamic power reduction < 300 W or active backup power mode):
    - If the PV power is above a specified threshold, energy saving mode is ended.
  - Battery charging from the public grid is requested via the user interface of the inverter.
  - The battery is being recharged in order to restore the minimum state of charge or perform calibration.
- 

## Special case

If the inverter does not operate for 12 minutes (e.g., fault), or there is an interruption in the electrical connection between the inverter and the battery and there is no backup power mode, the battery switches to energy-saving mode in any case. This reduces self discharge of the battery.

---

**Indication of energy saving mode**

During energy saving mode:

- Operating LED of the inverter lights up orange (see [Button functions and LED status indicator](#) on page 37).
- The user interface of the inverter can be reached.
- All the available data are saved and transmitted to Solar.web.
- The real-time data can be seen on Solar.web.

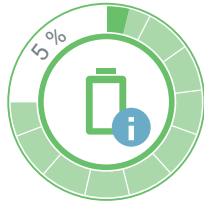

Energy saving mode is shown on the user interface of the inverter and in Solar.web by an "i" beside the battery symbol in the system overview.

# Suitable batteries

## General

Fronius explicitly points out that the third-party batteries are not Fronius products. Fronius is not the manufacturer, distributor, or retailer of these batteries. Fronius accepts no liability and offers no service or guarantees for these batteries.

Obsolete firmware/software states may lead to incompatibilities between the inverter and the battery. In this case, the following steps are to be performed:

- 1 Update battery software—see the battery documentation.
- 2 Update inverter firmware—see [Update](#) on page 127.

Read this document and the Installation Instructions before installing and commissioning the external battery. The documentation is either enclosed with the external battery or can be obtained from the battery manufacturer or their service partners

All documents associated with the inverter can be found at the following address:

<https://www.fronius.com/en/solar-energy/installers-partners/service-support/tech-support>

## Restrictions during operation

With a DC voltage on at least one MPPT above 520 V, the battery can no longer be charged or discharged. The voltage of 520 V is rarely exceeded during normal operation of the inverter.

When reducing the output power of the inverter, the operating point shifts toward higher DC voltages. The following general conditions during normal operation can lead to the DC voltage exceeding 520 V:

- Oversizing of the module array.
- Feed-in limit (e.g., zero feed-in).
- Specifications of the utility (e.g., grid-voltage-dependent power reduction).
- Backup power mode. If the voltage exceeds 520 V in a backup power situation, backup power mode may be restricted. Therefore, an open-circuit voltage of max. 520 V is recommended.

## Fronius batteries

Fronius Reserva		
Capacity [kWh]	6.3 - 12.6	15.8
Number of modules	2 - 4	5
Fronius Primo GEN24 SC <sup>1)</sup>	✓	✗
Fronius Primo GEN24 Plus SC	✓	✗
Battery parallel operation <sup>2)</sup>	✓	✗
Fronius Reserva Pro		
Capacity [kWh]	12.0 - 20.0	24.0 - 32.0

Fronius Reserva Pro		
Number of modules	3 - 5	6 - 8
Fronius Primo GEN24 SC <sup>1)</sup>	✓	✗
Fronius Primo GEN24 Plus SC	✓	✗
Battery parallel operation <sup>2)</sup>	✓	✗

- 1) Battery support optionally available.  
 2) Max. 4 batteries with the same capacity can be combined.

## BYD batteries

BYD Battery-Box Premium HVS BYD Battery-Box HVS+		
Capacity [kWh]	5.1 - 10.2	12.8
Number of modules	2 - 4	5
Fronius Primo GEN24 SC <sup>1)</sup>	✓	✗
Fronius Primo GEN24 Plus SC	✓	✗
Battery parallel operation <sup>2)</sup>	✓	✗

BYD Battery-Box Premium HVM BYD Battery-Box HVM+		
Capacity [kWh]	8.3	11.0 - 22.1
Number of modules	3	4 - 8
Fronius Primo GEN24 SC <sup>1)</sup>	✗	✓
Fronius Primo GEN24 Plus SC	✗	✓
Battery parallel operation <sup>2)</sup>	✗	✓

- 1) Battery support optionally available.  
 2) Max. 3 batteries with the same capacity can be combined.

### IMPORTANT!

See the battery manufacturer's documentation for the maximum DC cable length.

**IMPORTANT!**

The following switch-on sequence for the system must always be followed to ensure reliable operation with a BYD Battery-Box Premium.

**1**

Switch on the battery.

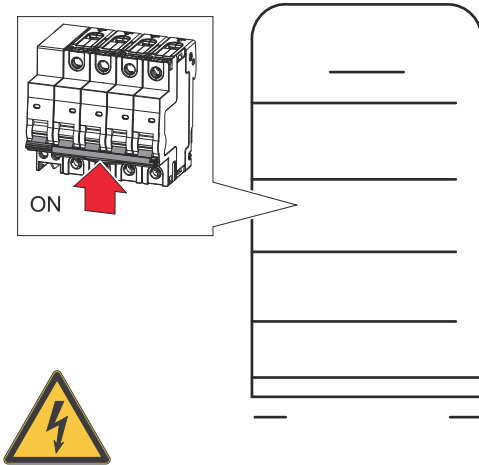

**2**

Turn on the automatic circuit breaker. Set the DC disconnecter to the "on" switch position.

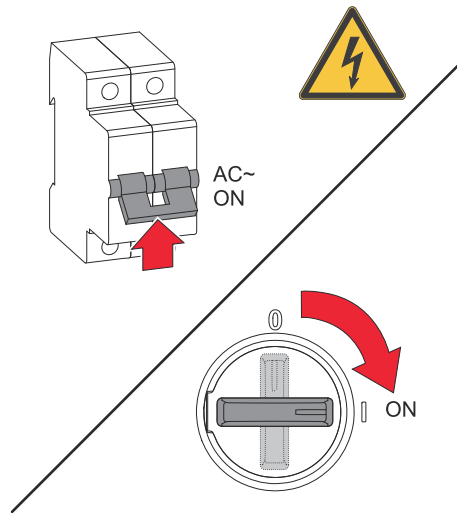

**LG FLEX**

LG FLEX	8.6	12.9	17.2
Number of battery modules	2	3	4
Fronius Primo GEN24 SC*	✓	✓	✗
Fronius Primo GEN24 Plus SC	✓	✓	✗

\* Battery support optionally available.

**IMPORTANT!**

According to the manufacturer, the max. DC cable length is 30 m. Refer to the manufacturer's documents for more detailed information.

## Switching on the battery

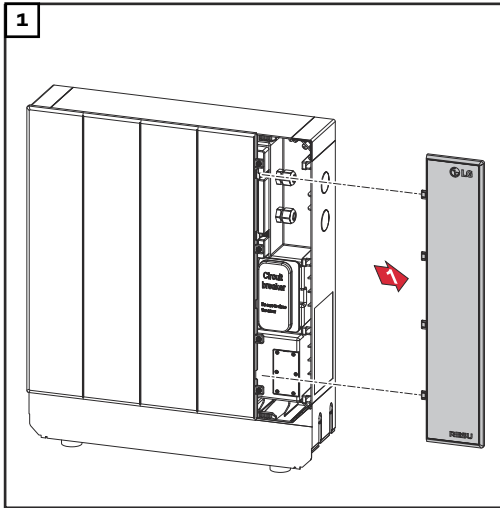

Pull off the cover to the right.

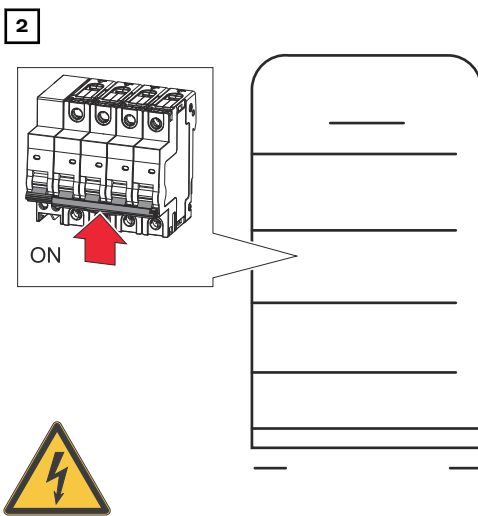

Pull off the cover of the DC disconnect to the front. Set the DC disconnect to the "on" switch position.

To assemble the battery, perform the steps listed above in reverse order.

# Manual system start

---

**Requirements** There is no energy available from the PV modules or from the public grid. If backup power operation or battery operation are not possible (e.g., deep discharge protection of the battery), the inverter and battery switch off.

---

**Notification of system shutdown** Status codes about the inactive state of the battery are displayed on the user interface of the inverter. A notification via e-mail can be activated in Fronius Solar.web.

---

**Manual battery start after system shutdown** As soon as energy is available again, the inverter starts operation automatically; however, the battery must be started manually. The switch-on sequence must be observed for this, see chapter [Suitable batteries](#) on page 27.

---

**Starting backup power operation after a system shutdown** The inverter requires energy from the battery to start backup power operation. This is done manually on the battery; further information on the power supply for restarting the inverter via the battery can be found in the battery manufacturer's Operating Instructions.

# Protection of people and equipment

---

## Central grid and system protection

The inverter offers the option to use the integrated AC relays as section switches in conjunction with a central grid and system protection unit (in accordance with VDE-AR-N 4105:2018:11 §6.4.1). For this purpose, the central trigger device (switch) must be integrated into the WSD chain as described in chapter [WSD \(wired shutdown\)](#) on page 32.

---

## WSD (wired shutdown)

The wired shutdown (WSD) interrupts the inverter's grid power feed if the trigger device (switch, e.g., Emergency Stop or fire alarm contact) has been activated.

If an inverter (slave) fails, it is bypassed and the other inverters continue operating. If a second inverter (slave) or the inverter (master) fails, the operation of the entire WSD chain is interrupted.

For installation, see [Installing the WSD \(wired shutdown\)](#) on page 102.

---

## RCMU

The inverter is equipped with an RCMU (RCMU = residual current monitoring unit) according to IEC 62109-2 and IEC63112. It monitors residual currents from the PV module up to the AC output and disconnects the inverter from the grid when an improper residual current is detected.

---

## Insulation monitoring

In the case of photovoltaic systems with ungrounded PV modules, the inverter checks the resistance between the positive or negative pole of the photovoltaic system and the ground potential before starting grid power feed operation. In the event of a short circuit between the DC+ or DC- cable and ground (e.g., due to inadequately insulated DC cables or defective PV modules), feeding into the public grid is prevented.

---

## AFCI - Arc Fault Circuit Interrupter (Arc Guard)

An AFCI (Arc Fault Circuit Interrupter) protects against arc faults and, in the narrower sense, is a protection device in the event of contact errors. The AFCI evaluates faults that occur in the current and voltage flow on the DC side using an electronic circuit and shuts down the circuit if a contact error is detected. This prevents overheating at poor contact points and, ideally, possible fires.

### CAUTION!

#### **Danger from faulty or incorrect DC installation.**

This may result in a risk of damage and, as a consequence, risk of fire in the PV system due to prohibited thermal loads that occur during an arc.

- ▶ Check the plug connections to ensure that they are correct.
- ▶ Repair faulty insulation correctly.
- ▶ Perform connection work in line with the instructions.

### **IMPORTANT!**

Fronius will not bear any costs that may arise due to a detected electric arc and its consequences. Fronius accepts no liability for damage which may occur des-

pite the integrated Arc Fault Circuit Interrupter/interruption (e.g., due to a parallel arc).

**IMPORTANT!**

Active PV module electronics (e.g., power optimizers) can impair the function of the Arc Fault Circuit Interrupter. Fronius cannot guarantee the correct function of the Arc Fault Circuit Interrupter in combination with active PV module electronics.

**Reconnection behavior**

Grid power feed operation is interrupted for at least 5 minutes after an arc has been detected. Depending on the configuration, grid power feed operation is then automatically resumed. If several arcs are detected within a period of 24 hours, grid power feed operation can also be permanently interrupted until a manual reconnection has been performed.

---

**Safe state**

In the safe state, the inverter infeed is deactivated and is disconnected from the grid by the AC relay opening. The inverter switches to the safe state when the following events occur:

1. One of the following safety devices triggers:
  - WSD
  - Insulation monitoring
  - RCMU
  - AFCI
2. The diagnostic function of the inverter detects a malfunction of these safety devices.

# Operating controls and connections

## Connection area

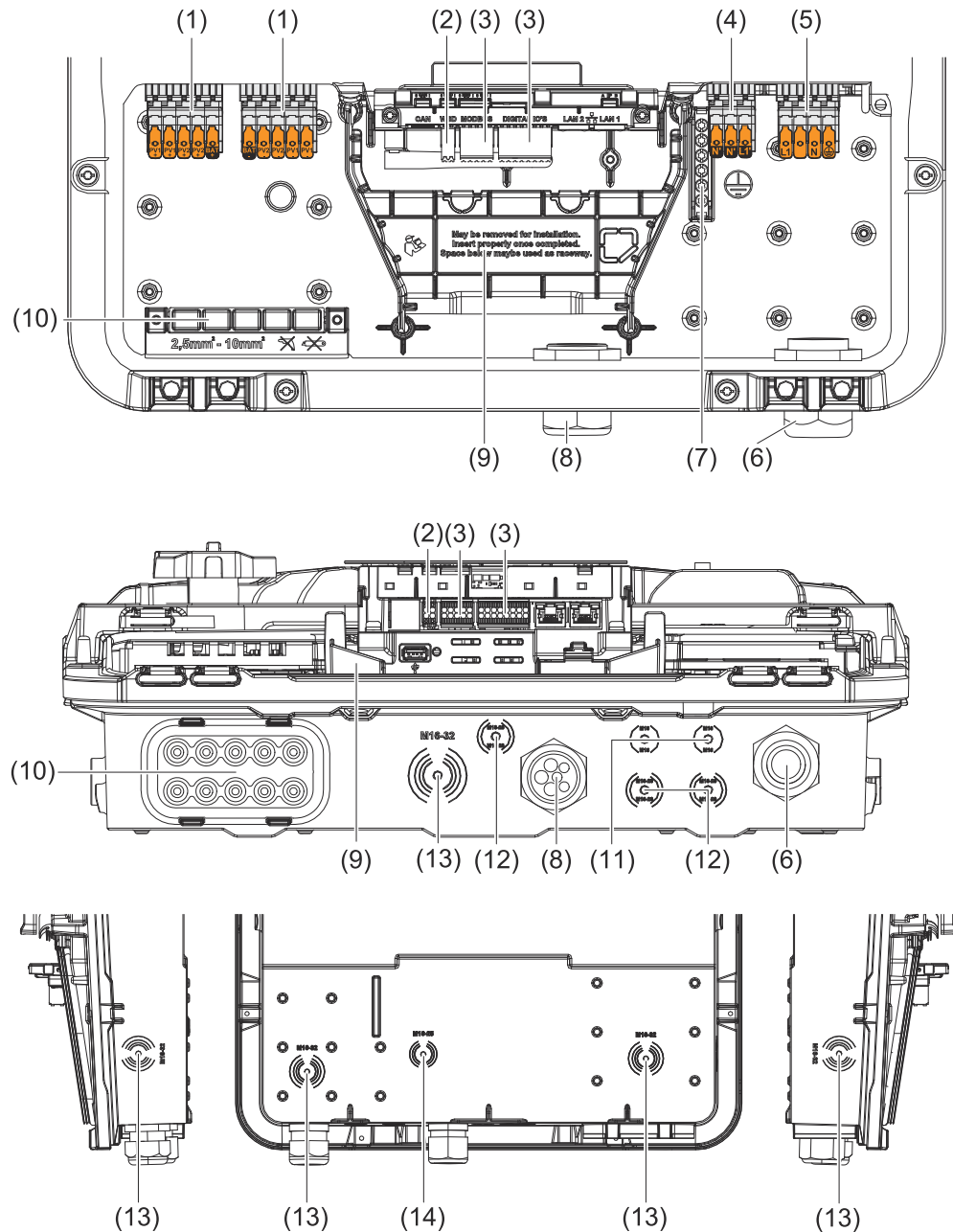

- (1) 2 x 5-pin DC push-in terminal
- (2) Push-in WSD (wired shutdown) terminal
- (3) Push-in terminals in the data communication area (Modbus, digital inputs and outputs)
- (4) 3-pin push-in terminal for PV Point (OP)
- (5) 3-pin AC push-in terminal
- (6) Cable gland/cable connection AC
- (7) 6-pin ground electrode terminal
- (8) Data communication area cable gland/cable connection
- (9) Connection area divider
- (10) 10 x DC glands

- (11) Optional cable gland (M16)
- (12) Optional cable gland (M16 - M20)
- (13) Optional cable gland (M16 - M32)
- (14) Optional cable gland (M16 - M25)

**Connection area divider**

The connection area divider separates the high-voltage conductors (DC and AC) from the signal lines. To make it easier to reach the connection area, the divider can be removed for the connection work, and must be re-inserted.

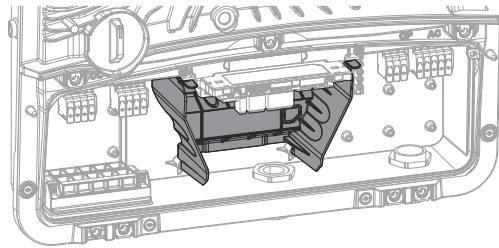

- (1) Integrated cable duct
- (2) Recesses for removing the connection area divider
- (3) Snap tabs for locking/unlocking
- (4) Defined breaking point for the DatCom connection

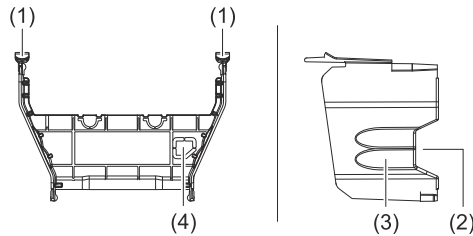

The integrated cable duct (1) allows for the lines to be laid from one area of the inverter to the other. As a result, multiple inverters can be easily installed next to each other.

**Ground electrode terminal**

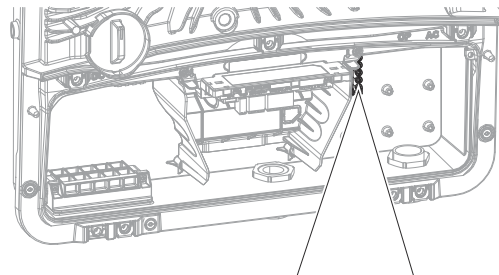

The ground electrode terminal  $\oplus$  provides the option of grounding additional components, such as:

- AC cable
- Module mounting system
- Ground spike

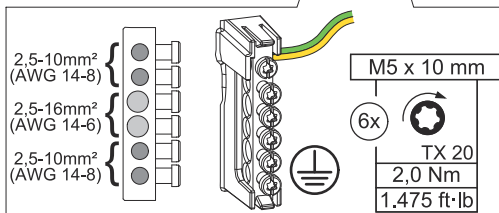

## DC disconnect

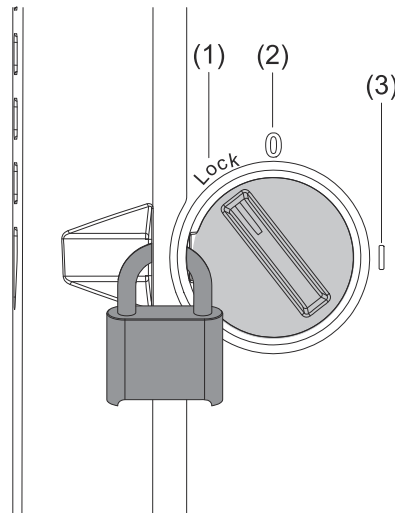

The DC disconnect has 3 switch settings:

- (1) Locked/off (turned to the left)
- (2) Off
- (3) On



### IMPORTANT!

In switch settings (1) and (3), the inverter can be secured to prevent it from being switched on/off using a standard padlock. The national guidelines must be complied with in this respect.

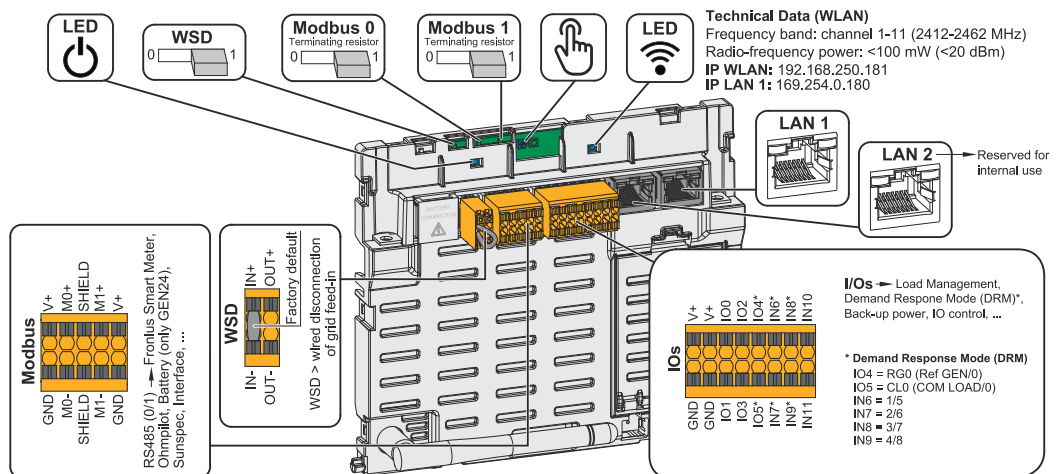
## Data communication area



<b>Operating LED</b>	Indicates the inverter operating status.
<b>WSD (wired shutdown) switch</b>	Defines the inverter as the WSD master or WSD slave.  <b>Position 1:</b> WSD master <b>Position 0:</b> WSD slave
<b>Modbus 0 (MBO) switch</b>	Switches the terminating resistor for Modbus 0 (MBO) on/off.  <b>Position 1:</b> Terminating resistor on (factory setting) <b>Position 0:</b> Terminating resistor off
<b>Modbus 1 (MB1) switch</b>	Switches the terminating resistor for Modbus 1 (MB1) on/off.  <b>Position 1:</b> Terminating resistor on (factory setting) <b>Position 0:</b> Terminating resistor off

 <b>Optical sensor</b>	For operating the inverter. See chapter <a href="#">Button functions and LED status indicator</a> on page 37.
 <b>Communications LED</b>	Indicates the inverter connection status.
<b>LAN 1</b>	Ethernet connection for data communication (e.g., WiFi router, home network or, for commissioning with a laptop, see chapter <a href="#">Installation with the browser</a> on page 105).
<b>LAN 2</b>	Reserved for future functions. To avoid malfunctions, only use LAN 1.
<b>I/O terminal</b>	Push-in terminal for digital inputs/ outputs. See chapter <a href="#">Permitted cables for the data communication connection</a> on page 69. The designations (RGO, CLO, 1/5, 2/6, 3/7, 4/8) relate to the Demand Response Mode function, see chapter <a href="#">Functions and I/Os</a> on page 113.
<b>WSD terminal</b>	Push-in terminal for the WSD installation. See chapter <a href="#">WSD (wired shut-down)</a> on page 32.
<b>Modbus terminal</b>	Push-in terminal for the installation of Modbus 0, Modbus 1, 12 V, and GND (ground).  The data connection to the connected components is established via the Modbus terminal. <b>The inputs M0 and M1 can be freely selected.</b> Max. 4 Modbus participants per input; see chapter <a href="#">Modbus participants</a> on page 97.

### Button functions and LED status indicator

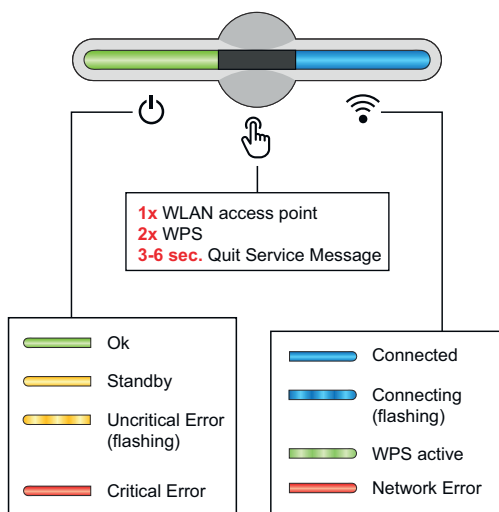

The operating status LED displays the status of the inverter. In case of faults, follow the individual steps in the Fronius Solar.start app.



The optical sensor is actuated by touching it with a finger.



The communications LED displays the connection status. To establish a connection, follow the individual steps in the Fronius Solar.start app.

## Sensor functions

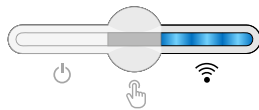

1x = WLAN access point (AP) is opened.

Flashes blue

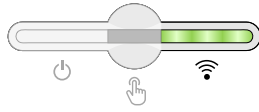

2x = WLAN protected setup (WPS) is activated.

Flashes green

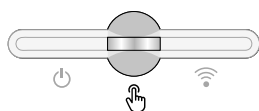

3 seconds (max. 6 seconds) = The service message disappears.

Flashes white (quickly)

## LED status indicator

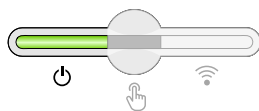

The inverter is operating correctly.

Lights up green

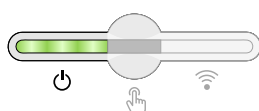

The inverter is performing the grid checks required by the applicable standards for grid power feed operation.

Flashes green

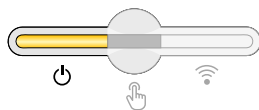

The inverter is on standby, is not operating (e.g., no energy fed into the grid at night), or is not configured.

Lights up yellow

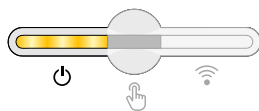

The inverter displays a non-critical status.

Flashes yellow

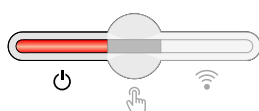

The inverter displays a critical status and no energy is fed into the grid.

Lights up red

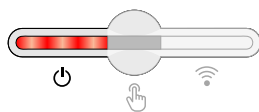

The inverter displays a backup power overload.

Flashes red

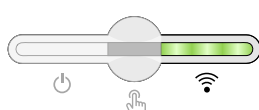

The network connection is being established via WPS.

2x = WPS search mode.

Flashes green

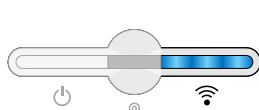

The network connection is being established via WLAN AP.

1x = WLAN AP search mode (active for 30 minutes).

Flashes blue

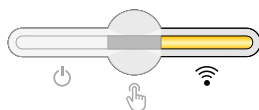

The network connection is not configured.

Lights up yellow

## LED status indicator

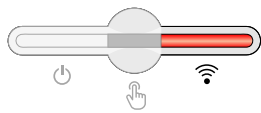

A network error is displayed, the inverter is operating correctly.

📶 Lights up red

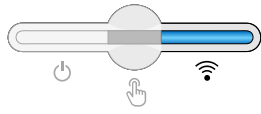

The network connection is active.

📶 Lights up blue

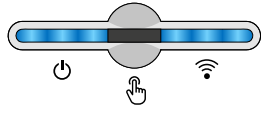

The inverter is performing an update.

🔌 / 📶 Flash blue

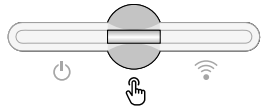

There is a service message.

👉 Lights up white

## Schematic internal wiring of IOs

The V+/ GND pin provides the possibility of feeding in a voltage in the range of 12.5 to 24 V (+ max. 20%) using an external power supply unit. Outputs IO 0 - 5 can then be operated using the external voltage that has been fed in. A maximum of 1 A may be drawn per output, whereby a total of max. 3 A is permitted. The fuse protection must take place externally.

### ⚠️ CAUTION!

**Danger from polarity reversal at the terminals due to improper connection of external power supply units.**

This may result in severe damage to the inverter.

- ▶ Check the polarity of the external power supply unit with a suitable measuring device before connecting it.
- ▶ Connect the cables to the V+/GND outputs while ensuring the correct polarity.

### IMPORTANT!

If the total output (6 W) is exceeded, the inverter switches off the entire external power supply.

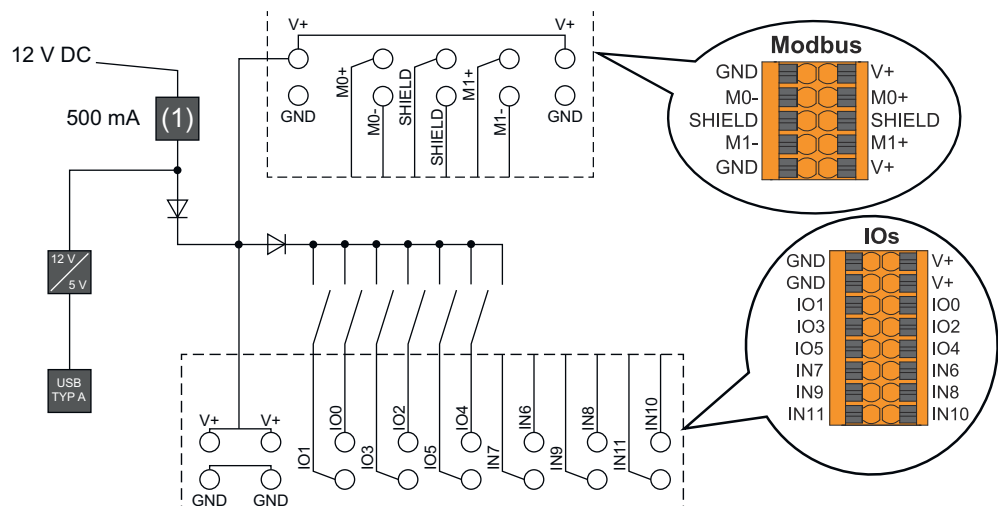

(1) Current limitation



# **Backup power variant - PV Point (OP)**



# General

---

## Explanatory note - PV Point/PV Point Comfort

### **IMPORTANT!**

If several backup power variants are available, please note that only one backup power variant may be installed and configured.

The inverter can provide 220-240 V at the PV Point/PV Point Comfort. A corresponding configuration must be set up during commissioning.

At 220-240 V output voltage, max. 13 A AC continuous current is available.

### **Example:**

220 V \* 13 A = 2,860 W

230 V \* 13 A = max. 3 kW

In backup power mode, some electrical appliances cannot function properly as starting currents are too high (for example, fridges and freezers). It is recommended to switch off non-essential loads during backup power mode. Overload capacity of 35% is possible for a duration of 5 seconds, depending on the capacity of the PV modules and/or the battery at that moment in time.

There is a brief interruption when switching from grid-connected mode to backup power mode. For this reason, the backup power function cannot be used as an uninterruptible power supply, for example for computers.

If no energy from the battery or the PV modules is available in backup power mode, backup power mode ends automatically. If sufficient energy becomes available from the PV modules once again, backup power mode starts again automatically.

In the event of excessive consumption, backup power mode is stopped and the "backup power overload" status code is displayed on the inverter's LED status indicator (see [Button functions and LED status indicator](#) on page 37). The maximum power in backup power mode according to the technical data must be observed.

---

## PV Point (OP)

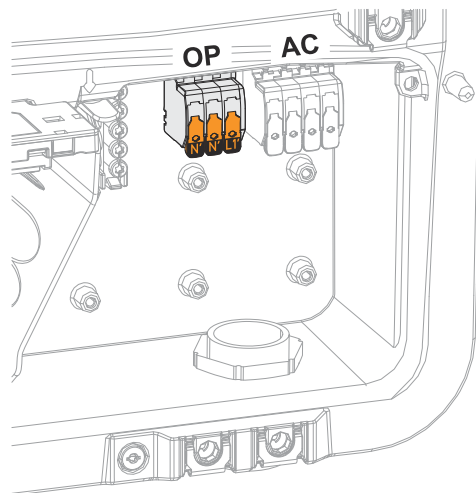

With the PV Point, in the event of a failure of the public grid, 1-phase electrical devices can be connected to the Opportunity Power (OP) terminal and supplied with a maximum power of 3 kW, if enough power is available in the solar modules or an optional battery. In grid-connected operation, the OP terminal is not supplied with voltage, therefore the connected loads will not be permanently supplied with power.

### **IMPORTANT!**

A grid switchover with relay is not possible.

For the installation instructions, see chapter [Connecting backup power - PV Point \(OP\)](#) on page 86.

## PV Point Comfort

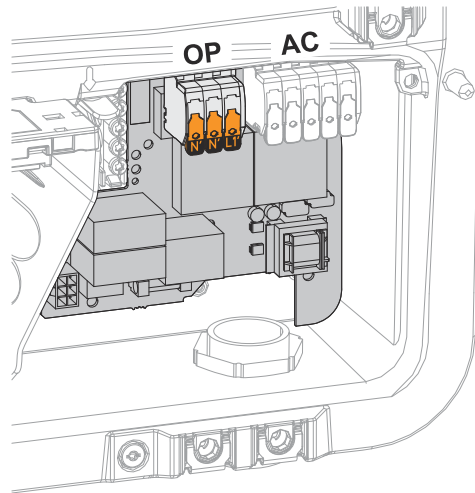

With the PV Point Comfort, 1-phase electrical devices are permanently supplied with a maximum power of 3 kW.

Switching between grid connected and backup power mode takes place automatically. In the event of a failure of the public grid or the inverter, the PV Point Comfort permanently supplies connected loads. When the grid becomes available again and stability is ensured, the PV Point Comfort automatically switches to grid connected mode and backup power mode is terminated.

### **IMPORTANT!**

Backup power mode requires sufficient power from the PV modules or a battery. The PV Point Comfort is not available in Australia and New Zealand.

For further information and the installation instructions, see chapter [PV Point Comfort](#) on page 172.

# **Backup power variant - Full Backup**



# General

---

## Prerequisites for backup power mode

### IMPORTANT!

If several backup power variants are available, it is important to note that only one backup power variant may be installed and configured.

The following prerequisites must be met in order to use the inverter's backup power function:

- The inverter must support the backup power variant 'Full Backup' (see chapter [Function overview](#) on page 17).
- A battery suitable for backup power use must be installed and configured.
- Correct cabling of the backup power system in the electrical installation (see chapter [Components for automatic backup power changeover to Full Backup](#) on page 189 or [Circuit diagrams—automatic switch to backup power with Fronius Backup Controller](#) on page 237).
- Install and configure the Fronius Smart Meter at the feed-in point.
- Attach a [backup power supply warning](https://www.fronius.com/en/search-page, item number: 42,0409,0275) (https://www.fronius.com/en/search-page, item number: 42,0409,0275) to the electrical distributor.
- Apply the necessary settings in the **Devices and system components > Functions and pins > Backup Power** menu item and activate backup power.
- Go through the [checklist - Backup power](https://www.fronius.com/en/search-page, item number: 42,0426,0365) (https://www.fronius.com/en/search-page, item number: 42,0426,0365) step by step and confirm.

---

## Transitioning from grid power feed operation to backup power mode

1. The public grid is monitored by the inverter's internal grid and system protection unit and by the Fronius Smart Meter connected to it.
2. **The public grid fails or specific grid parameters are undershot or exceeded.**
3. The inverter carries out the measures necessary according to the country standard and then switches off.
4. The inverter starts backup power mode after a checking period.
5. All loads in the household that are in the backup power circuit are supplied by the battery and the PV modules. The remaining loads are not supplied with power and are safely isolated.

---

## Transitioning from backup power mode to grid power feed operation

1. The inverter is operating in backup power mode.
2. **The public grid is functioning correctly again.**
3. The Fronius Smart Meter monitors the grid parameters on the public grid and passes this information to the inverter.
4. The stability of the restored public grid is determined by checking the measured values of the Fronius Smart Meter.
5. Backup power mode is terminated automatically or manually depending on the design of the backup power switchover facility.
6. All circuits are reconnected to the public grid and are supplied by the grid.
7. The inverter can start grid power feed operation again after performing the grid checks required by the relevant standard.

---

## Backup power and energy saving mode

Under the following conditions, the battery and the inverter are switched to energy saving mode after a waiting time of 8-12 minutes and backup power mode is ended:

- The battery is discharged to the minimum state of charge and no energy is coming from the PV modules.
- The inverter is set to energy saving mode (standby mode).

If the battery and inverter are in energy saving mode, the system is reactivated by the following:

- Enough energy is available from the PV modules.
- The public grid is functioning again.
- The battery is switched off and on.

# Automatic switch to backup power incl. backup power circuits and 1-pin separation, e.g., Australia

---

## Functions

- Measuring and transferring the required parameters for energy management and Solar.web by the Fronius Smart Meter.
  - Disconnecting from the public grid to enable operation in backup power mode if the grid parameters are outside the country-specific standards.
  - Reconnecting to the public grid when the grid parameters are within the limits specified by the country-specific standards.
  - Option of having a separate backup power circuit or several backup power circuits that are supplied even during failure of the public grid. The total load of the backup power circuits must not exceed the nominal output of the inverter. Furthermore, the performance of the connected battery must also be considered.
- 

## Transitioning from grid power feed operation to backup power mode

1. The public grid is monitored by the inverter's internal grid and system protection unit and by the Fronius Smart Meter connected to it.
  2. **Failure of the public grid.**
  3. The inverter carries out the measures necessary according to the country standard and then switches off.  
Contactor K1 drops out. This disconnects the backup power circuits and the inverter from the rest of the home network and from the public grid, as the main contacts of contactor K1 open. The inverter activates relay K3, which interrupts the supply to contactor K1. This prevents unintentional activation of contactor K1 and thus a grid connection when voltage is restored in the grid. The NC auxiliary contacts of contactor K1 send feedback to the inverter that the contactor is open (a condition for starting backup power mode).
  4. The NO contact of relay K3 gives additional feedback to the inverter on whether the locking was successfully performed by relay K3.
  5. The inverter decides based on the contactor's feedback as well as the measurements on the inverter terminals that the backup power mode can be activated.
  6. After all the required activation tests have been carried out, the inverter starts backup power mode.
  7. All loads in the backup power circuits are supplied with power. The remaining loads are not supplied with power and are safely isolated.
- 

## Transitioning from backup power mode to grid power feed operation

1. The inverter is operating in backup power mode. Contactor K1 to the public grid is open.
2. **Public grid available again.**
3. The Fronius Smart Meter monitors the grid parameters on the public grid and passes this information to the inverter.
4. The stability of the restored public grid is determined by checking the measured values of the Fronius Smart Meter.
5. The inverter ends backup power mode and disconnects the outputs.
6. The inverter deactivates K3. Contactor K1 is reactivated.
7. All circuits are reconnected to the public grid and are supplied by the grid. The inverter does not feed anything into the grid at this time.
8. The inverter can start grid power feed operation again after performing the grid checks required by the relevant standard.

# Automatic switch to backup power all-pin separation, e.g., Germany, France, UK, Spain

---

## Functions

- Measuring and transferring the required parameters for energy management and Solar.web by the Fronius Smart Meter.
  - Disconnecting from the public grid to enable operation in backup power mode if the grid parameters are outside the country-specific standards.
  - Reconnecting to the public grid when the grid parameters are within the limits specified by the country-specific standards.
  - Establishing a proper ground connection for backup power mode to ensure the protection devices function correctly.
  - Option of having a separate backup power circuit or several backup power circuits that are supplied even during failure of the public grid. The total load of the backup power circuits must not exceed the rated power of the inverter. Furthermore, the performance of the connected battery must also be considered.
- 

## Transitioning from grid power feed operation to backup power mode

1. The public grid is monitored by the inverter's internal grid and system protection unit and by the Fronius Smart Meter connected to it.
2. **Failure of the public grid.**
3. The inverter carries out the necessary measures according to the country standard and then switches off.  
Contactors K1, K4, and K5 drop out. This disconnects the backup power circuits and the inverter from the rest of the home network and from the public grid, as the main contacts of contactor K1 open (all-pin). The NC auxiliary contacts of contactor K1 send feedback to the inverter that the contactor is open (a condition for starting backup power mode).
4. The NC main contacts of contactors K4 and K5 are closed, establishing a connection between the neutral conductor and the ground conductor. The two other NC main contacts of contactors K4 and K5 give feedback to the inverter that the ground connection has been established correctly (a condition for starting backup power mode).
5. The inverter activates relay K3, which interrupts the supply to contactors K1, K4, and K5. This prevents unintentional activation of contactors K1, K4, and K5 and thus a grid connection when voltage is restored in the grid.
6. The NO contact of relay K3 gives additional feedback to the inverter on whether the locking was successfully performed by relay K3.
7. The inverter decides based on the contactors' feedback as well as the measurements on the inverter terminals that the backup power mode can be started.
8. After all the required activation tests have been carried out, the inverter starts backup power mode.
9. All loads in the backup power circuits are supplied with power. The remaining loads are not supplied with power and are safely isolated.

---

**Transitioning  
from backup  
power mode to  
grid power feed  
operation**

1. The inverter is operating in backup power mode. Contactor K1 to the public grid is open.
2. **Public grid available again.**
3. The Fronius Smart Meter monitors the grid parameters on the public grid and passes this information to the inverter.
4. The stability of the restored public grid is determined by checking the measured values of the Fronius Smart Meter.
5. The inverter ends backup power mode and disconnects the outputs.
6. The inverter deactivates K3. Power is restored to contactors K1, K4, and K5.
7. All circuits are reconnected to the public grid and are supplied by the grid. The inverter does not feed anything into the grid at this time.
8. The inverter can start grid power feed operation again after performing the grid checks required by the relevant standard.

# Automatic switch to backup power all-pin separation, Italy

---

## Functions

- Measuring and transferring the required parameters for energy management and Solar.web by the Fronius Smart Meter.
  - Monitoring of the voltage and frequency grid parameters by the inverter.
  - Disconnecting from the public grid to enable operation in backup power mode if the grid parameters are outside the country-specific standards.
  - Reconnecting to the public grid when the grid parameters are within the limits specified by the country-specific standards.
  - Establishing a correct ground connection for backup power mode.
  - Option of having a separate backup power circuit or several backup power circuits that are supplied even during failure of the public grid. The total load of the backup power circuits must not exceed the nominal output of the inverter. Furthermore, the performance of the connected battery must also be considered.
- 

## Transitioning from grid power feed operation to backup power mode

1. The public grid is monitored by the inverter's internal grid and system protection unit and by an external grid and system protection unit.
2. **Failure of the public grid**
3. The inverter carries out the measures necessary according to the country standard and then switches off.
4. The external grid and system protection unit opens contactors K1 and K2 for grid monitoring. This disconnects the backup power circuits and the inverter from the rest of the home network and from the public grid, as the main contacts of contactors K1 and K2 open (all-pin). To ensure that the public grid has definitely been disconnected, the NC auxiliary contacts of contactor K1 give feedback to the external grid and system protection unit.
5. The NC main contacts of contactors K4 and K5 are closed, establishing a connection between the neutral conductor and the ground conductor. The two other NC main contacts of contactors K4 and K5 give feedback to the inverter that the ground connection has been established correctly.
6. The inverter activates relay K3, which activates the remote input of the external grid and system protection unit via an NC contact. This prevents a connection to the public grid when voltage is restored in the grid.
7. The NO contact of relay K3 gives additional feedback to the inverter on whether the locking was successfully performed by relay K3.
8. The inverter decides based on the contactor's feedback as well as the measurement on the inverter terminals that the backup power mode can be activated.
9. The inverter starts backup power mode after a defined checking period.
10. All loads in the backup power circuits are supplied with power. The remaining loads are not supplied with power and are safely isolated.

---

**Transitioning  
from backup  
power mode to  
grid power feed  
operation**

1. The inverter is operating in backup power mode. The contactors K1 and K2 to the public grid are open.
2. **Public grid available again.**
3. The Fronius Smart Meter monitors the grid parameters on the public grid and passes this information to the inverter.
4. The stability of the restored public grid is determined by checking the measured values of the Fronius Smart Meter.
5. On the basis of adjustments that have been carried out, the inverter ends backup power mode and disconnects the outputs.
6. The inverter deactivates K3. Power is restored to contactors K1, K2, K4, and K5.
7. All circuits are reconnected to the public grid and are supplied by the grid. The inverter does not feed anything into the grid at this time.
8. The inverter can start grid power feed operation again after performing the grid checks required by the relevant standard.

# Manual switch to backup power 1-pin separation, e.g., Australia / 2-pin separation, e.g., Germany

---

## Functions

- Measuring and transferring the required parameters for energy management and Solar.web by the Fronius Smart Meter.
- Monitoring of the grid parameters by the inverter.
- Possibility of manual separation from the public grid if it fails or is deemed unstable.
- Option of having a separate backup power circuit or several backup power circuits that are supplied even during failure of the public grid. The total load of the backup power circuits must not exceed the rated power of the inverter. Furthermore, the performance of the connected battery must also be considered.
- If, in the event of a public grid failure, there is no manual switch to backup power mode within the first 10 minutes, this may cause the inverter and the battery to shut down. In order to then start backup power mode, manual switching must take place and a manual system start must be performed, if necessary (see chapter [Manual system start](#) on page 31).
- It is possible to manually reconnect the inverter and loads in the backup power circuit to the public grid once it is deemed to be stable again. The inverter only starts feed-in mode once the required grid monitoring time has passed.

---

## Transition from grid power feed operation to backup power mode

1. The public grid is monitored by the inverter's internal grid and system protection and by the connected Fronius Smart Meter.
2. **Failure of the public grid.**
3. The inverter takes the necessary measures according to the country standard and then switches off.
4. The user switches the Fronius Backup Switch from switch position 1 (grid operation) via switch position 0 to switch position 2 (backup power mode). This disconnects the backup power circuits and the inverter from the rest of the home network and from the public grid. In the case of all-pole disconnection, the connection of ground conductor and neutral conductor is also made via the main contacts of the switch. Switch position 2 (backup power mode) is fed back to the inverter via a main contact of the Fronius Backup Switch. In addition, when the Fronius Backup Switch switches via switch position 0, the WSD line is interrupted. This causes the inverter to switch off immediately. This behavior is ensured via 2 contacts. The communication between the inverter and the Fronius Smart Meter is optionally prevented via a contact. The suspended communication prevents automatic termination of backup power mode when power returns to the public grid. The inverter then remains in backup power mode until it is manually switched back again.
5. Based on the feedback for switch position 2 and the measurements at the inverter terminals, the inverter decides that backup power mode can be started.
6. After all required connection tests have been carried out, the inverter starts in backup power mode.
7. All loads that are in the backup power circuits are supplied. The remaining loads are not supplied and are safely disconnected.

---

**Transitioning  
from backup  
power mode to  
grid power feed  
operation**

1. The inverter is operating in backup power mode. Changeover switch Q1 is in switch position 2 (backup power mode).
2. **Public grid available again.**
3. The user switches the changeover switch Q1 from switch position 2 (backup power mode) via switch position 0 to switch position 1 (grid operation). When switching via switch position 0, the inverter is switched off immediately. This is ensured via the contacts of the changeover switch Q1. To protect sensitive loads, it is advisable to remain in the zero position for at least 1 second during the changeover process from backup power mode to the public grid.
4. The inverter is again connected to the entire home network and to the public grid.
5. Communication between the inverter and Fronius Smart Meter is re-established.
6. The inverter can start grid power feed operation again after performing the grid checks required by the relevant standard.



# Installation



# General

## Quick-fastener system

### NOTE!

#### Danger when using a drill driver.

This may result in the destruction of the quick-fastener system due to over-torque.

- ▶ Use a screwdriver (TX20).
- ▶ Do not turn the screws more than 180°.

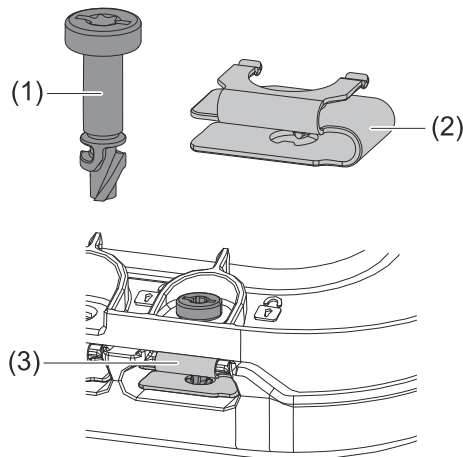

A quick-fastener system (3) is used to mount the connection area cover and front cover. The system is opened and closed with a half-rotation (180°) of the captive screw (1) into the quick-fastener spring (2).

The system is independent of torque.

## Information on the device

Technical data, warning notices, labels, and safety symbols are located on the inverter. This information must be kept in a legible condition and must not be removed, covered, pasted over, or painted over. The notices and safety symbols warn against incorrect operation, which may result in serious injury and property damage.

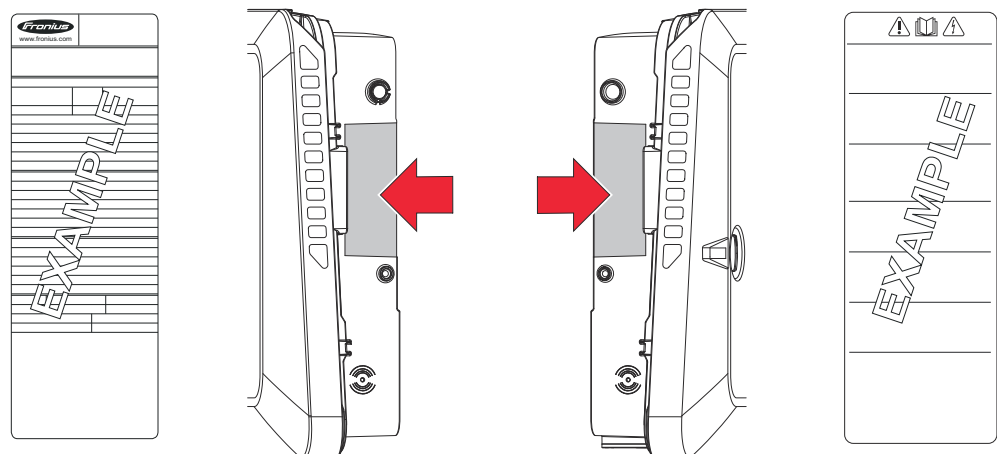

### Symbols on the rating plate:

**CE** CE label – confirms compliance with applicable EU directives and regulations.



WEEE marking – waste electrical and electronic equipment must be collected separately and recycled in an environmentally sound manner in accordance with the European Directive and national law.



RCM marking – tested according to the requirements of Australia and New Zealand.



CMIM marking – tested according to IMANOR requirements for import regulations and compliance with Moroccan standards.



Anatel marking – ANATEL certification is a procedure in Brazil that ensures that telecommunications products and electronic equipment meet the technical and regulatory requirements established by the Brazilian National Telecommunications Agency (ANATEL).

#### Safety symbols:



Integrated switch disconnecter on the input side of the inverter with switch-on, switch-off, and isolating function according to IEC 60947-3 and AS 60947.3. The values required by the applicable standard for *I<sub>the solar</sub>* +60°C are given.



Risk of serious injury and property damage due to incorrect operation.



Do not use the functions described here until you have fully read and understood the following documents:

- These operating instructions.
- All operating instructions for the system components of the photovoltaic system, especially the safety rules.



Dangerous electrical voltage.



Allow the capacitors of the inverter to discharge (2 minutes).

#### Warning notice text:

#### WARNING!

An electric shock can be fatal. Before opening the device, ensure that the input and output sides are de-energized and disconnected.

#### System component compatibility

All installed components in the PV system must be compatible with each other and have the necessary configuration options. The installed components must not restrict or negatively affect the functioning of the PV system.

#### NOTE!

#### Risk due to components in the PV system that are not and/or only partially compatible.

Incompatible components can restrict and/or negatively affect the operation and/or functioning of the PV system.

- ▶ Only install components recommended by the manufacturer in the PV system.
- ▶ Before installation, check the compatibility of components that have not been expressly recommended with the manufacturer.

# Installation location and position

## Choosing the location of the inverter

Please observe the following criteria when choosing a location for the inverter:

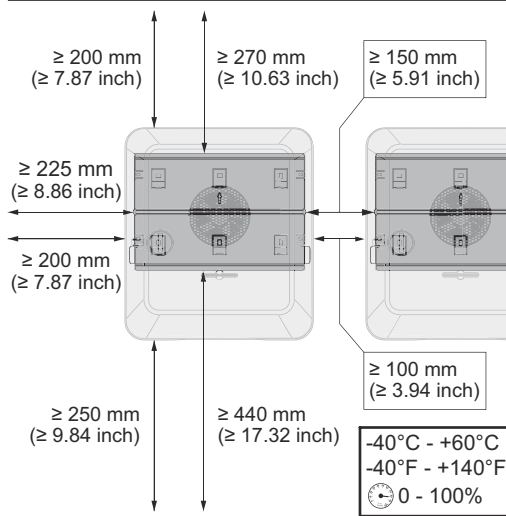

Only install on a solid, non-flammable surface.

Max. ambient temperatures:  
-40 °C - +60 °C  
-40 °F - +140 °F

Relative humidity:  
0-100%

When installing the inverter in a switch cabinet or similar closed environment, it is necessary to make sure that the hot air that develops will be dissipated by forced-air ventilation.

For more detailed information on inverter dimensions, refer to the chapter headed [Dimensions of the inverter](#) on page 255.

When installing the inverter on the outer walls of cattle sheds, it is important to maintain a minimum clearance of 2 m between all sides of the inverter and the ventilation and building openings.

The following substrates are permissible for installation:

- Walls (corrugated metal walls [mounting rails], brick walls, concrete walls, or other non-flammable surfaces sufficiently capable of bearing loads)
- Mast or beam (installed using mounting rails, behind the PV modules directly on the PV mounting system)
- Flat roofs (if this is for a film roof, make sure that the films comply with the fire protection requirements and are not highly flammable. Ensure compliance with the national provisions.)
- Covered parking lot roofs (no overhead installation)



The inverter is suitable for indoor installation.



The inverter is suitable for outdoor installation.

Because of its IP 66 protection class, the inverter is not susceptible to water spray from any direction and can also be operated in moist environments.

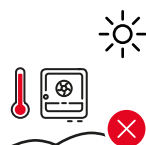

In order to keep inverter heating as low as possible, do not expose the inverter to direct sunlight.



The inverter should be installed in a protected location, e.g., near the PV modules or under an overhanging roof.

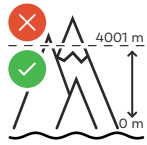

The inverter must not be installed or operated at more than 4,000 m above sea level.



Do not install the inverter:

- Where it may be exposed to ammonia, corrosive gases, acids, or salts (e.g., fertilizer storage areas, vent openings for livestock stables, chemical plants, tanneries)



During certain operating phases the inverter may produce a slight noise. For this reason it should not be installed in an occupied living area.



Do not install the inverter in:

- Areas where there is an increased risk of accidents from farm animals (e.g., horses, cattle, sheep, pigs)
- Stables or adjoining areas
- Storage areas for hay, straw, chaff, animal feed, and fertilizers



The inverter is essentially designed to be dustproof (IP 66). In areas of high dust accumulation, dust deposits may collect on the cooling surfaces, and thus impair the thermal performance. Regular cleaning is required in this case, see chapter [Operation in dusty environments](#) on page 185. We therefore recommend not installing the inverter in areas and environments with high dust accumulation.



Do not install the inverter in:

- Greenhouses
- Storage or processing areas for fruit, vegetables, or viticulture products
- Areas used in the preparation of grain, green fodder, or animal feeds

### Choosing the location of third-party batteries

#### **IMPORTANT!**

Refer to the manufacturer's documents for specifications regarding the suitable location of third-party batteries.

**Installation position of the inverter**



The inverter is suitable for vertical installation on a vertical wall or column.

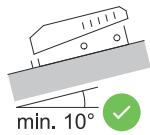
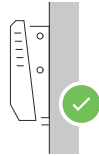

The inverter is suitable for installation on a sloping surface (min. slope of underside 10°).

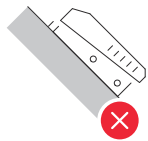

Do not install the inverter on a sloping surface with the connections upwards.



Do not install the inverter in a sloping position on a vertical wall or column.



Do not install the inverter in a horizontal position on a vertical wall or column.



Do not install the inverter with the connections upwards on a vertical wall or column.

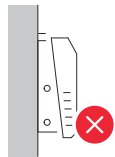

Do not install the inverter overhanging with the connections upwards.

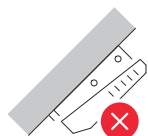

Do not install the inverter overhanging with the connections downwards.

Do not install the inverter on the ceiling.

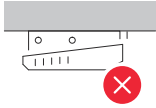

# Installing the mounting bracket and attaching the inverter

---

## Selecting the mounting material

Use the corresponding fixing materials depending on the subsurface and observe the screw dimension recommendations for the mounting bracket. The installer is responsible for selecting the right type of fixing.

---

## Properties of the mounting bracket

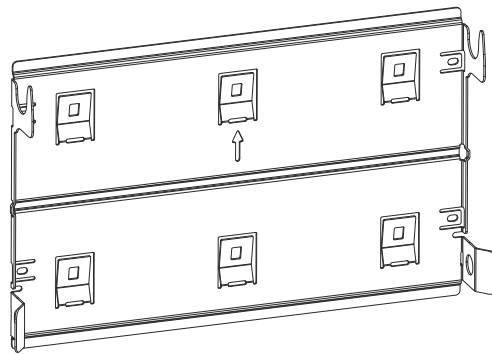

The mounting bracket (illustration) can also be used as a guide.

The pre-drilled holes on the mounting bracket are intended for screws with a thread diameter of 6-8 mm (0.24-0.32 inches). The distance from the left to the right pre-drilled hole is 406 mm (16 inches).

Unevenness on the mounting surface (e.g. coarse-textured plaster) is largely compensated by the mounting bracket.

---

## Do not deform the mounting bracket

### NOTE!

**When attaching the mounting bracket to the wall or to a column, make sure that the mounting bracket is not deformed.**

A deformed mounting bracket may make it difficult to clip/swivel the inverter into position.

---

## Fitting the mounting bracket to a wall

### IMPORTANT!

When installing the mounting bracket, make sure that it is installed with the arrow pointing upwards.

---

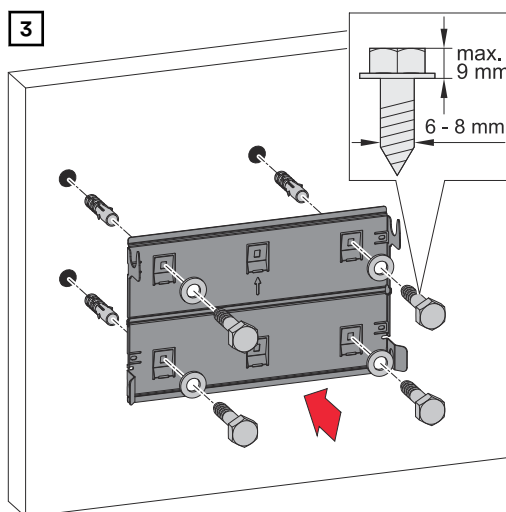
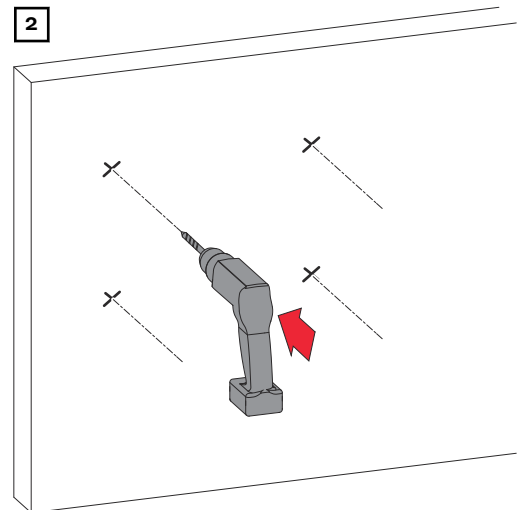
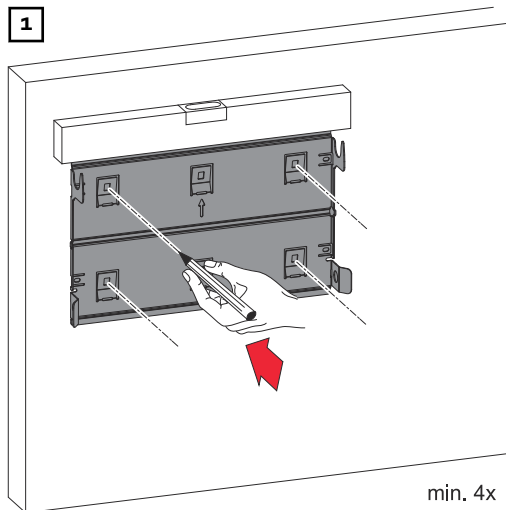

**Installing the mounting bracket on a mast or beam**

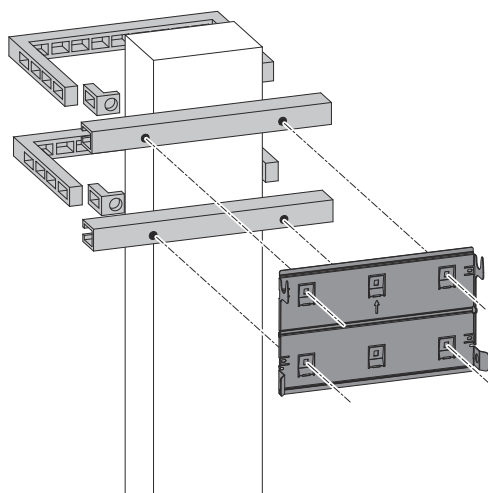

When installing the inverter on a mast or beam, Fronius recommends using the "Pole clamp" (order no. SZ 2584.000) mounting kit from Rittal GmbH.

The "Pole clamp" kit covers the following dimensions:

- Rectangular mast or beam with a side length of 50–150 mm (1.97–5.91 inches)
- Round mast or beam with a diameter of 40–190 mm (1.57–7.48 inches)

**Attaching the mounting bracket to mounting rails**

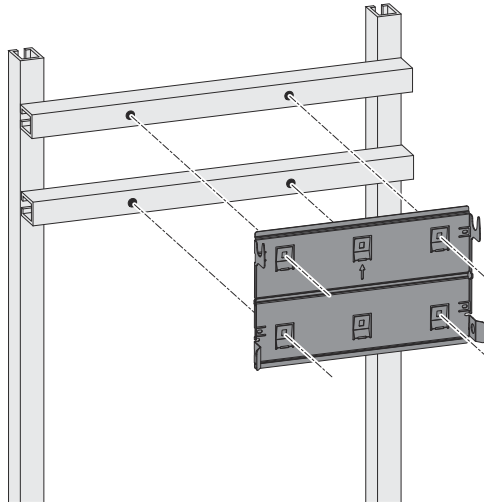

**IMPORTANT!**

The mounting bracket must be affixed at a minimum of four points.

**Attaching the inverter to the mounting bracket**

**1**

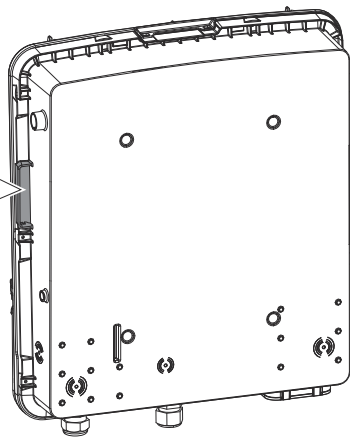
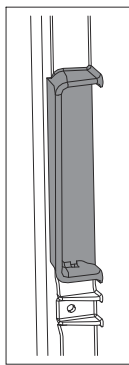

Lift the inverter by the integrated side handles.

**2**

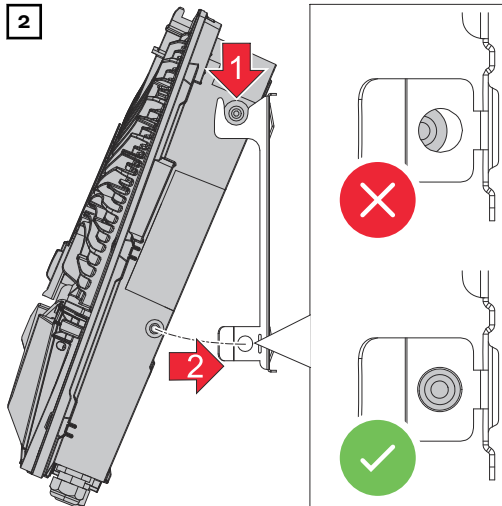

Clip the inverter into the mounting bracket from above. The connections must point downwards.

Press the lower area of the inverter into the snap-in tabs on the mounting bracket until the inverter engages on both sides with an audible click.

**3**

Check that the inverter is correctly in position on both sides.

# Requirements for connecting the inverter

Different cable types

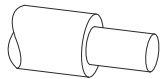
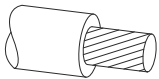
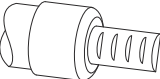
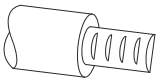
Single-core	Multi-stranded	Fine-stranded	Fine-stranded with ferule and collar	Fine-stranded with ferule without collar
				

Permissible cables for the electrical con-

Round copper conductors can be connected to the terminals of the inverter as described below.

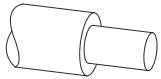
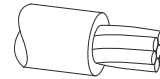
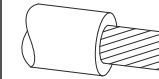
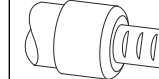
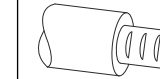
Grid connections with push-in terminal*					
Select a sufficiently large cable cross-section based on the actual device output.					
Number of pins					
3	2.5-10 mm <sup>2</sup> AWG 14-8	2.5-10 mm <sup>2</sup> AWG 14-8	2.5-10 mm <sup>2</sup> AWG 14-8	2.5-6 mm <sup>2</sup> AWG 14-10	2.5-6 mm <sup>2</sup> AWG 14-10

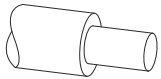
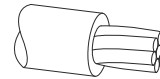
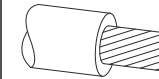
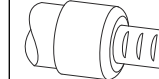
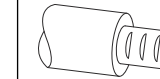
Grid connections, backup power with push-in terminal*					
Select a sufficiently large cable cross-section based on the actual device output!					
Number of pins					
3	1.5-10 mm <sup>2</sup> AWG 16-8	1.5-10 mm <sup>2</sup> AWG 16-8	1.5-10 mm <sup>2</sup> AWG 16-8	1.5-6 mm <sup>2</sup> AWG 16-10	1.5-6 mm <sup>2</sup> AWG 16-10

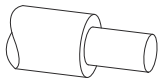
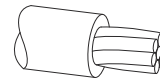
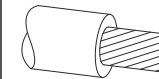
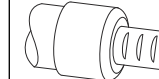
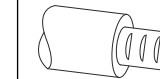
PV/BAT connections with push-in terminal**					
Select a sufficiently large cable cross-section based on the actual device output.					
Number of pins					
2 x 5	4-10 mm <sup>2</sup> AWG 12-8	4-10 mm <sup>2</sup> AWG 12-8	4-10 mm <sup>2</sup> AWG 12-8	4-6 mm <sup>2</sup> AWG 12-10	4-6 mm <sup>2</sup> AWG 12-10

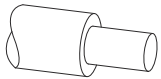
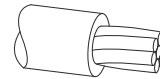
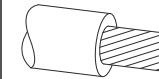
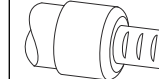
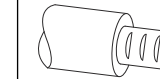
Ground electrode terminal (6-pin)					
Select a sufficiently large cable cross-section based on the actual device output.					
Number of pins					

## Ground electrode terminal (6-pin)

Select a sufficiently large cable cross-section based on the actual device output.

2	2.5-16 mm <sup>2</sup> AWG 14-6	2.5-16 mm <sup>2</sup> AWG 14-6	2.5-16 mm <sup>2</sup> AWG 14-6	2.5-16 mm <sup>2</sup> AWG 14-6	2.5-16 mm <sup>2</sup> AWG 14-6
4	2.5-10 mm <sup>2</sup> AWG 14-8	2.5-10 mm <sup>2</sup> AWG 14-8	2.5-10 mm <sup>2</sup> AWG 14-8	2.5-10 mm <sup>2</sup> AWG 14-8	2.5-10 mm <sup>2</sup> AWG 14-8

\* According to product standard IEC 62109, the ground conductor must correspond to the phase cross-section for phase cross-sections ≤16 mm<sup>2</sup>, while for phase cross-sections >16 mm<sup>2</sup>, it must be at least 16 mm<sup>2</sup>.

For a conductor cross-section of 1.5 mm<sup>2</sup>, the maximum permissible cable length is 100 m.

\*\* The cable cross-section must be dimensioned in accordance with the installation situation and the specifications of the battery manufacturer.

### Permitted cables for the data communication connection

Cables with the following design can be connected to the terminals of the inverter:

- Copper: round, solid
- Copper: round, fine-stranded

### IMPORTANT!

If several single conductors are connected to an input of the push-in terminal, connect the single conductors with a corresponding ferrule.

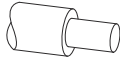
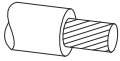
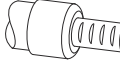
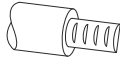

### WSD connections with push-in terminal

Distance	Stripping length					Cable recommendation
100 m 109 yd	10 mm 0.39 inch	0.14-1.5 mm <sup>2</sup> AWG 26-16	0.14-1.5 mm <sup>2</sup> AWG 26-16	0.14-1 mm <sup>2</sup> AWG 26-18	0.14 -1.5 mm <sup>2</sup> AWG 26-16	Min. CAT 5 UTP (unshielded twisted pair)

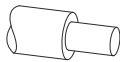
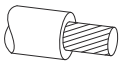
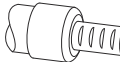
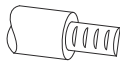
### Modbus connections with push-in terminal

Distance	Stripping length					Cable recommendation
300 m 328 yd	10 mm 0.39 inch	0.14-1.5 mm <sup>2</sup> AWG 26-16	0.14-1.5 mm <sup>2</sup> AWG 26-16	0.14-1 mm <sup>2</sup> AWG 26-18	0.14-1.5 mm <sup>2</sup> AWG 26-16	Min. CAT 5 STP (shielded twisted pair)

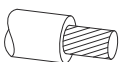
### IO connections with push-in terminal

Distance	Stripping length					Cable recommendation
30 m 32 yd	10 mm 0.39 inch	0.14-1.5 mm <sup>2</sup> AWG 26-16	0.14-1.5 mm <sup>2</sup> AWG 26-16	0.14-1 mm <sup>2</sup> AWG 26-18	0.14-1.5 mm <sup>2</sup> AWG 26-16	Single conductors possible

## LAN connections

Fronius recommends using at least CAT 5 STP (shielded twisted pair) cables and a maximum distance of 100 m (109 yd).

### Cable diameter of the AC cable

For a standard M32 cable gland **with a reducer**:  
7-15 mm

For a standard M32 cable gland **without a reducer**:  
11-21 mm

(with a cable diameter of less than 11 mm, the strain-relief force is reduced from 100 N to a maximum of 80 N)

With cable diameters greater than 21 mm, the M32 cable gland must be replaced by an M32 cable gland with a larger clamping area—item number: 42,0407,0780—strain-relief device M32 x 1.5 KB 18-25.

### Cable diameter of DC cable

Cable diameter for strain relief: max. 9 mm.

Cable diameter for the connection to the push-in terminal: max. 7 mm

#### IMPORTANT!

For double-insulated cables with a cable diameter above 7 mm, the outer layer of insulation must be removed for the connection to the push-in terminal.

### Maximum alternating current fuse protection

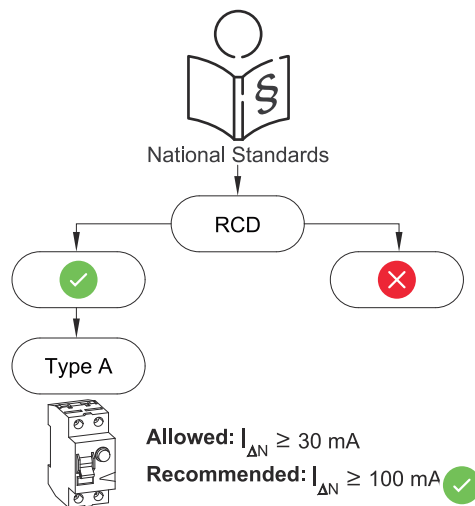

#### NOTE!

**A residual current circuit breaker for the AC connecting cable may be required depending on national regulations, the grid operator, and other conditions.**

A type A residual current circuit breaker is generally sufficient in this case. Nevertheless, false alarms can be triggered for the type A residual current circuit breaker in individual cases and depending on local conditions. For this reason, Fronius recommends using a residual current circuit breaker suitable for frequency inverters with a tripping current of at least 100 mA (national provisions must be taken into account).

AC~

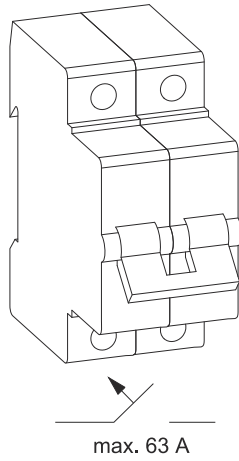

**IMPORTANT!**

The inverter may be fused with a 63 A automatic circuit breaker as a maximum.

Inverter	Phase s	AC power	Maximum fuse protection	Recommended fuse protection
Fronius Primo GEN24 3.0 kW SC	1	3,000 W	63 A	32 A
Fronius Primo GEN24 3.6 kW SC	1	3,680 W	63 A	32 A
Fronius Primo GEN24 4.0 kW SC	1	4,000 W	63 A	40 A
Fronius Primo GEN24 4.6 kW SC	1	4,600 W	63 A	40 A
Fronius Primo GEN24 5.0 kW SC	1	5,000 W	63 A	40 A
Fronius Primo GEN24 6.0 kW SC	1	6,000 W	63 A	40 A

# Connecting the inverter to the public grid (AC side)

## Safety

### **WARNING!**

#### **Danger due to incorrect operation and incorrectly performed work.**

This can result in serious injury and damage to property.

- ▶ Read the installation and operating instructions before installing and commissioning the equipment.
- ▶ Only qualified personnel are authorized to commission your inverter and only within the scope of the respective technical regulations.

### **WARNING!**

#### **Danger due to grid voltage and DC voltage from solar modules that are exposed to light.**

An electric shock can be fatal.

- ▶ Prior to any connection work, disconnect the inverter on the AC side and the DC side.
- ▶ Only an authorized electrical engineer is permitted to connect this equipment to the public grid.

### **WARNING!**

#### **Danger due to damaged and/or contaminated terminals.**

This can result in serious injury and damage to property.

- ▶ Before making any connections, check the terminals for damage and contamination.
- ▶ Remove contamination in the de-energized state.
- ▶ Have defective terminals repaired by an authorized specialist.

### **IMPORTANT!**

National standards and guidelines regarding load unbalance must be taken into account. The inverter does not have a communication link and does not automatically disconnect from the grid when the load unbalance is exceeded.

If the inverter is installed in Australia or New Zealand (required standard: AS/NZS4777.2:2020), the inverter must not be used as part of a three-phase combination, as there is no communication link between the inverters.

## Connecting the inverter to the public grid (AC side)

### **NOTE!**

#### **The neutral conductor must be connected in order to operate the inverter.**

It is not possible to operate the inverter in ungrounded grids, e.g., IT grids (insulated grids without ground conductor).

- ▶ Make sure that the grid's neutral conductor is grounded.

1

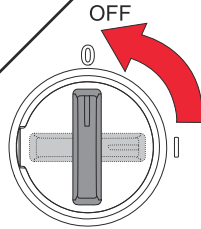
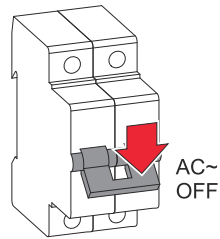

Turn off the automatic circuit breaker. Set the DC disconnect to the "off" switch position.

2

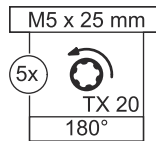
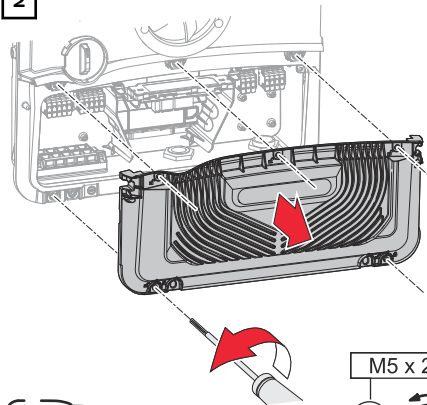

Loosen the 5 screws on the connection area cover by rotating them 180° to the left using a screwdriver (TX20). Remove the connection area cover from the device.

3

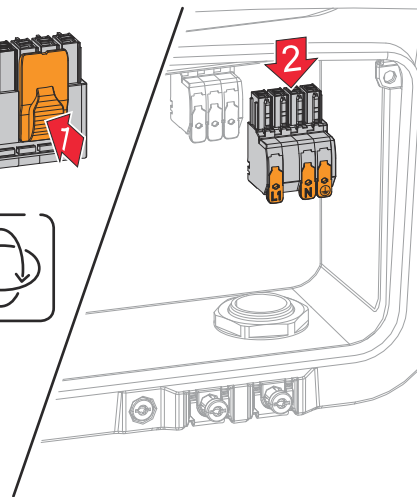
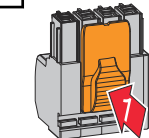

Press the latch on the back of the terminal and remove the AC terminal.

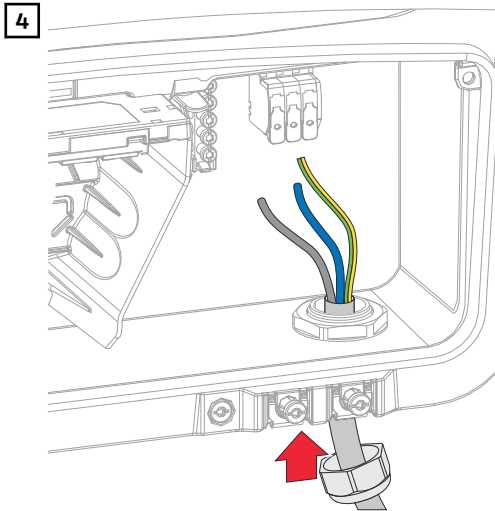

4 Guide the mains cable from below through the cable gland on the right side.

**IMPORTANT!**

The ground conductor must be dimensioned longer and laid with a movement loop so that it is last loaded in the event of a failure of the cable gland.

For more information about the cable gland, see chapter [Cable diameter of the AC cable](#) on page 70.

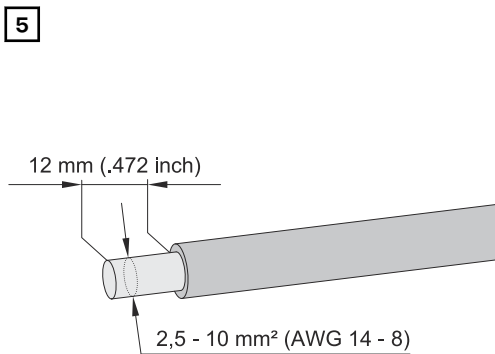

5 Select the cable cross-section in accordance with chapter [Permissible cables for the electrical connection](#) on page 68.

Strip 12 mm of insulation from the single conductors.

CU-Wire min:  
75° C / 167° F

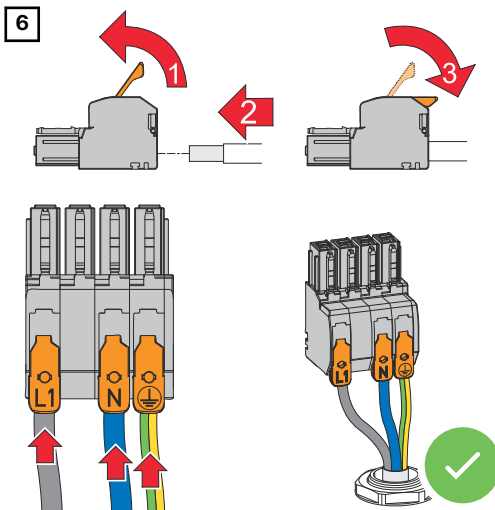
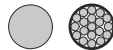

6 Lift to open the terminal's operating lever and insert the stripped single conductor into the slot provided, all the way up to the stop. Then close the operating lever until it engages.

**IMPORTANT!**

Only one conductor may be connected to each pin. The AC cables can be connected to the AC terminal without ferrules.

- L1 Phase conductor
- N Neutral conductor
- PE Ground conductor

7

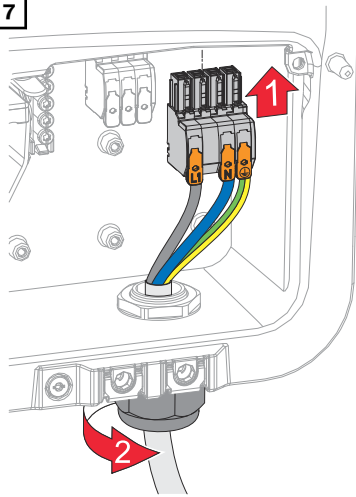

Insert the AC terminal into the AC slot until it engages. Fasten the union nut of the cable gland with a torque of 6 - 7 Nm.

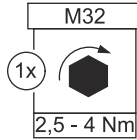
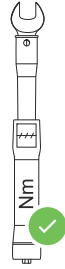

# Connecting solar module strings to the inverter

## General information about PV modules

To enable suitable PV modules to be chosen and to use the inverter as efficiently as possible, it is important to bear the following points in mind:

- If insolation is constant and the temperature is falling, the open-circuit voltage of the PV modules will increase. The open-circuit voltage must not exceed the max. permissible system voltage. An open-circuit voltage above the indicated values will damage the inverter, and all warranty rights will become null and void.
- The temperature coefficients on the data sheet of the PV modules must be observed.
- Exact values for sizing the PV modules can be obtained using suitable calculation tools, such as the [Fronius Solar.creator](#).

### IMPORTANT!

Before connecting up the PV modules, check that the voltage for the PV modules specified by the manufacturer corresponds to the actual measured voltage.

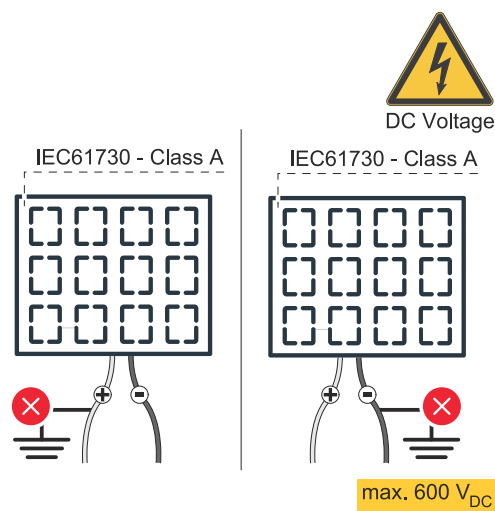

### IMPORTANT!

The PV modules connected to the inverter must comply with the IEC 61730 Class A standard.

### IMPORTANT!

Solar module strings must not be grounded.

## Safety

### WARNING!

#### **Danger from incorrect operation and work that is not carried out properly.**

This can result in severe personal injury and damage to property.

- ▶ The commissioning, maintenance, and service work in the inverter's power stage set may only be carried out by Fronius-trained service personnel in accordance with the technical specifications.
- ▶ Read the installation instructions and operating instructions before installing and commissioning the equipment.

**⚠ WARNING!**

**Danger from mains voltage and DC voltage from PV modules that are exposed to light.**

This can result in severe personal injury and damage to property.

- ▶ All connection, maintenance, and service work should only be carried out when the AC and DC sides have been disconnected from the inverter and are de-energized.
- ▶ Only an authorized electrical engineer is permitted to connect this equipment to the public grid.

**⚠ WARNING!**

**Danger of an electric shock due to improperly connected terminals/PV plug connectors.**

An electric shock can be fatal.

- ▶ When connecting, ensure that each pole of a string is routed via the same PV input, e.g.:  
**+ pole string 1** to the input **PV 1.1+** and **- pole string 1** to the input **PV 1.1-**

**⚠ WARNING!**

**Danger from damaged and/or contaminated terminals.**

This can result in severe personal injury and damage to property.

- ▶ Prior to connection work, check the terminals for damage and contamination.
- ▶ Remove any contamination while the equipment is de-energized.
- ▶ Have defective terminals replaced by an authorized specialist company.

**PV Generator, general**

Two independent PV inputs (PV 1 and PV 2) are available. These inputs can be connected to a different number of modules.

When starting for the first time, set up the PV Generator in accordance with the respective configuration (can also be carried out at a later date in the **Device Configuration > Components** menu area).

**Module array configuration 3 - 6 kW**

**IMPORTANT!**

Carry out the installation in accordance with the nationally applicable standards and guidelines.

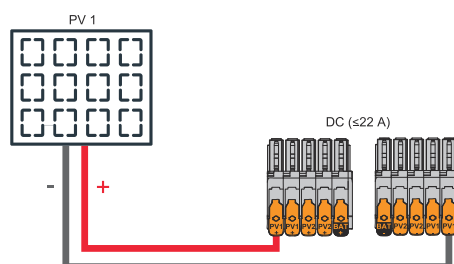

**Module array settings:**

PV 1: **ON**  
PV 2: **OFF**

Current less than or equal to 22 A ( $I_{dcmax}$ ).

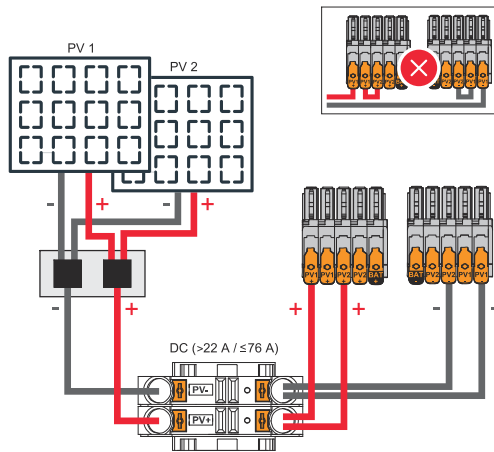

Combined solar module strings with total current greater than 22 A ( $I_{dcmax}$ ).

**Module array settings:**

PV 1: **ON**

PV 2: **OFF**

PV 1 + PV 2 (connected in parallel):

**ON**

**IMPORTANT!**

The maximum current load of a single terminal is 22 A. PV-connection strings with a total current of more than 22 A must be split between both PV inputs upstream of the terminals ( $I_{SC\ max} \leq 76\ A$ ). The plug connection for splitting the total current must be sufficiently dimensioned, suitable, and installed by a professional. It is not permitted to split the current by bridging from PV 1 to PV 2 at the terminal.

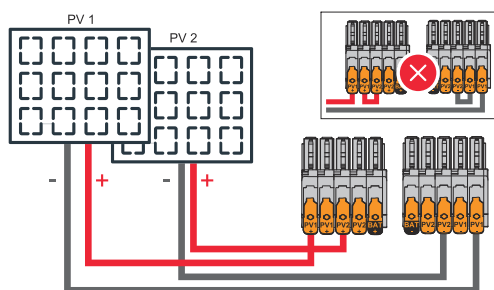

PV 1 less than or equal to 44 A ( $I_{SC\ PV1}$ )  
 PV 2 less than or equal to 32 A ( $I_{SC\ PV2}$ )

**Module array settings:**

PV 1: **ON**

PV 2: **ON**

**Connecting solar module strings to the inverter**

1

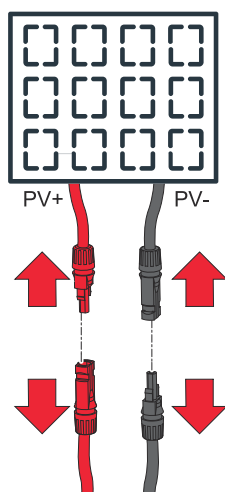

DC Voltage

Disconnect connections from the solar module strings (+/-).

max. 600 V<sub>DC</sub>

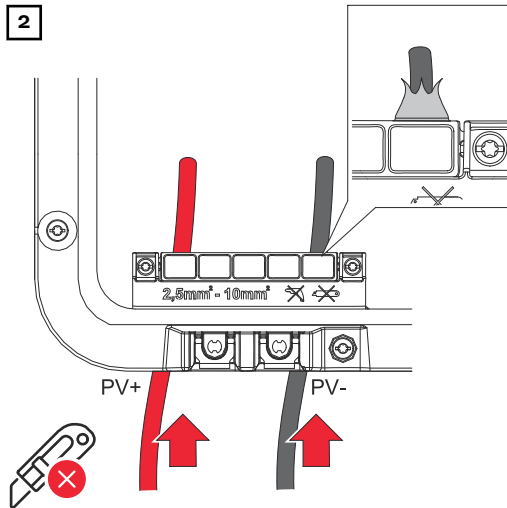

Push the DC cables through the DC bushings by hand.

**IMPORTANT!**

Push the cables through the DC bushing before stripping them in order to avoid twisting/bending single wires.

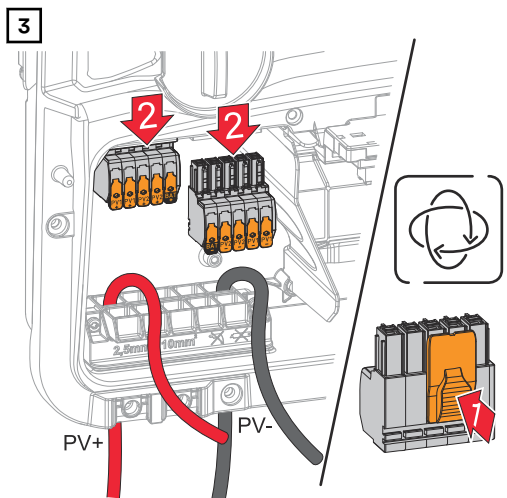

Remove the DC push-in terminals from the slots.

For measurements on the DC cables, use the Fronius Inspection Kit (44,0240,0004) or an adapter cable with a suitable DC plug (e.g., MC4). Connect the adapter cable to the DC push-in terminals and place the DC plug outside the inverter.

**WARNING!**

**Danger from loose and/or incorrectly clamped single conductors in the terminal.**

This can result in serious injury and damage to property.

- ▶ Only connect one single conductor at each slot provided in the terminal.
- ▶ Check that the single conductors are secure in the terminal.
- ▶ Make sure that the single conductor has been fully inserted into the terminal and that no single wires are protruding out of the terminal.

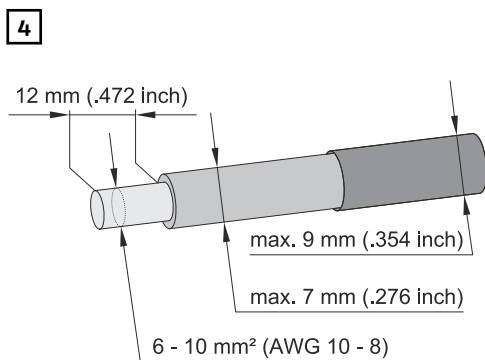

Select the cable cross-section in accordance with the instructions in [Permissible cables for the electrical connection](#) from page 68.

Strip the insulation of the single conductors by 12 mm.

CU-Wire min:  
75° C / 167° F



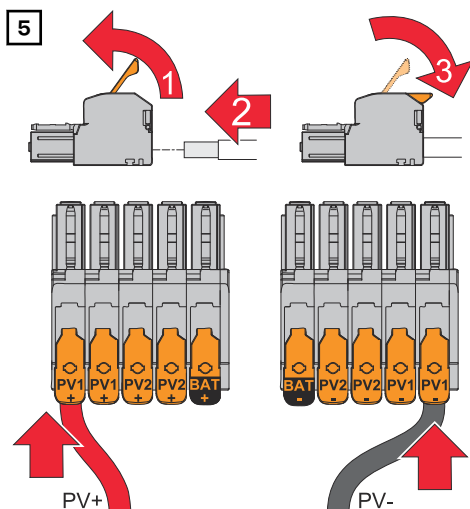

Lift to open the terminal's operating lever and insert the stripped single conductor into the slot provided, in each case as far as it will go. Then close the operating lever until it engages.

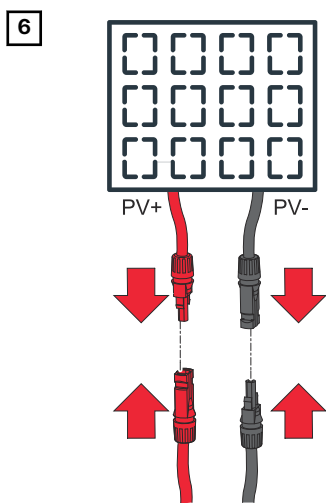

Connect the solar module strings (+/-).

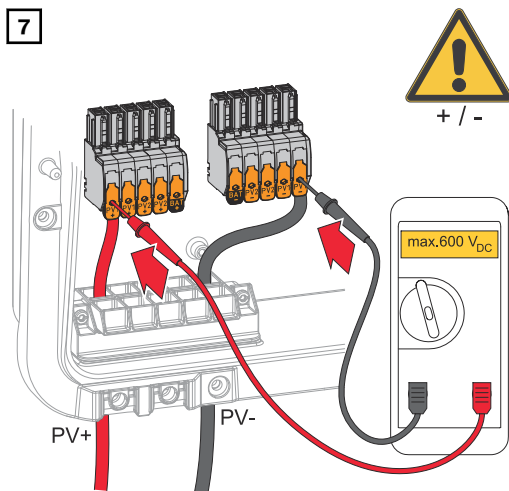

Use a suitable measuring instrument to check the voltage and polarity of the DC cabling. Remove both DC terminals from the slots.

**CAUTION!**

**Danger due to polarity reversal at the terminals.**

This may result in severe damage to the inverter.

- ▶ Use a suitable measuring instrument to check the polarity of the DC cabling.
- ▶ Use a suitable measuring instrument to check the voltage (**max. 600 V<sub>DC</sub>**).

8

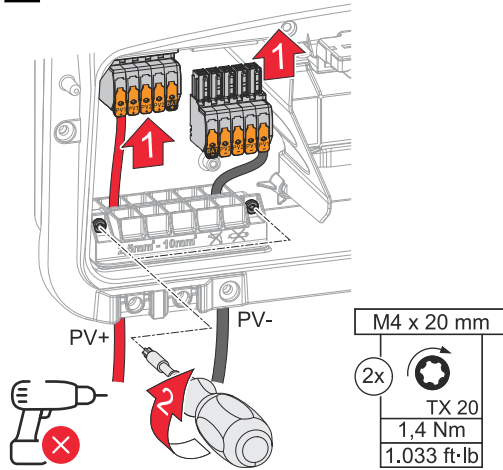

Insert the DC terminals into the respective slot until they engage. Fasten the screws of the cable guide to the housing using a screwdriver (TX20) and a torque of 1.3-1.5 Nm.

**NOTE!**

**Risk due to overtorque at the strain-relief device.**

Damage to the strain-relief device may result.

► Do not use a drill driver.

# Connecting the battery to the inverter

## Safety

### **WARNING!**

#### **Danger due to incorrect operation and incorrectly performed work.**

This can result in serious injury and damage to property.

- ▶ Only a technical specialist is permitted to perform commissioning, maintenance, and service activities for inverters and batteries, and only within the scope of the technical regulations.
- ▶ Read the installation instructions and operating instructions from the respective manufacturer before installing and commissioning the equipment.

### **WARNING!**

#### **Danger from mains voltage and DC voltage from the PV module that are exposed to light, as well as batteries.**

This can result in serious injury and damage to property.

- ▶ All connection, maintenance, and service work should only be carried out when the AC and DC sides have been disconnected from the inverter and battery, and are de-energized.
- ▶ Only a technical specialist is permitted to connect this equipment to the public grid.

### **WARNING!**

#### **Danger from damaged and/or contaminated terminals.**

This can result in serious injury and damage to property.

- ▶ Prior to connection work, check the terminals for damage and contamination.
- ▶ Remove any contamination while the equipment is de-energized.
- ▶ Have defective terminals repaired by a technical specialist.

## Connecting the battery on the DC side

### **CAUTION!**

#### **Danger due to operation of the battery above the permissible altitude specified by the manufacturer.**

Operating the battery above the permissible altitude can result in restricted operation, loss of operation, and unsafe states of the battery.

- ▶ Adhere to the manufacturer's instructions regarding the permissible altitude.
- ▶ Operate the battery only at the altitude specified by the manufacturer.

### **IMPORTANT!**

Prior to installing a battery, ensure that the battery is switched off. The max. DC cable length for the installation of third-party batteries must be taken into account according to the specifications of the manufacturer, see chapter [Suitable batteries](#) on page 27.

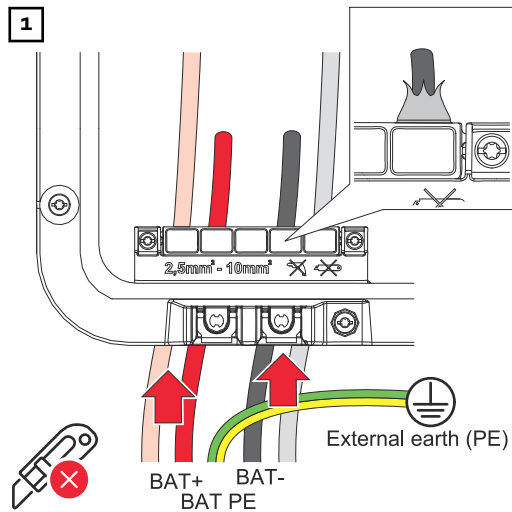

Push the battery cables through the DC bushings by hand. This avoids twisting/bending single wires.

\* The battery ground conductor must be connected externally (e.g., switch cabinet). When connecting an LG FLEX battery, the battery ground conductor can be connected in the inverter, see chapter [Connecting the LG FLEX ground conductor](#) on page 84. Observe the minimum cross-section of the battery ground conductor.

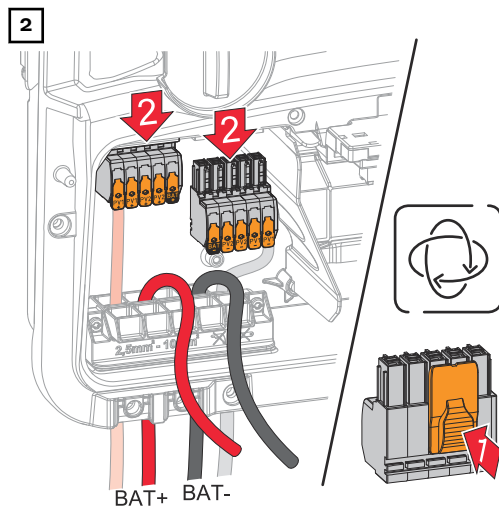

Remove the DC push-in terminals from the slots.

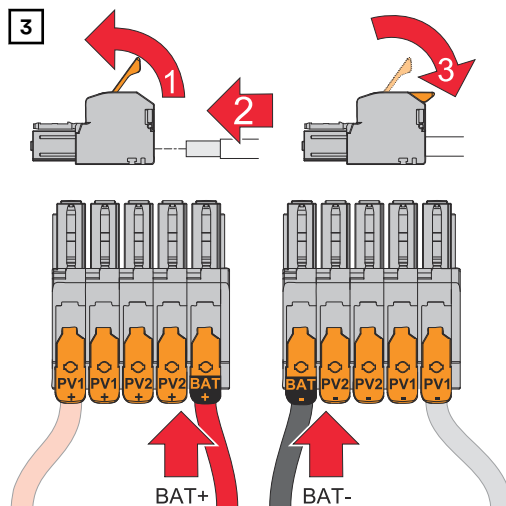

**CAUTION!**

**Danger due to overvoltage when using other slots on the terminal.** This may result in damage to the battery and/or the PV modules due to discharge.

- Only use the slots labeled "BAT" for connecting the battery.

4

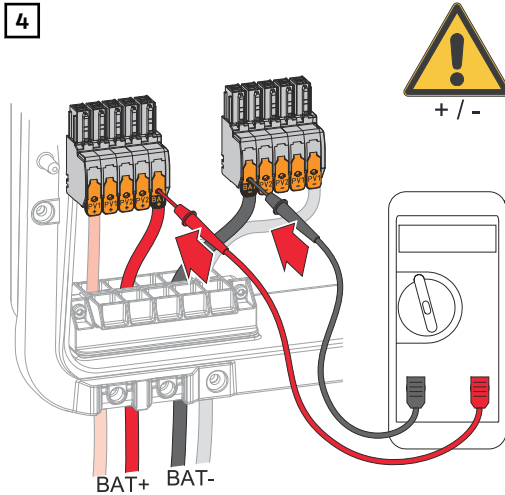

**CAUTION!**

**Danger due to polarity reversal at the terminals.**

Serious damage to the PV system may result.

- ▶ Use a suitable measuring instrument to check the polarity of the DC cabling when the battery is switched on.
- ▶ The maximum voltage for the battery input must not be exceeded (see [Technical data](#) on page 193).

5

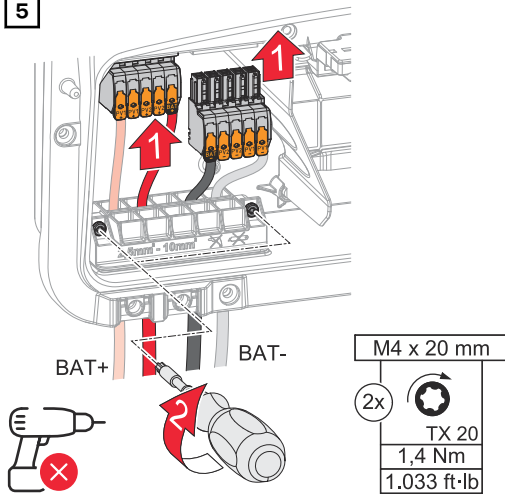

Insert the DC terminals into the respective slot until they engage.

Fasten the screws of the cable guide to the housing using a screwdriver (TX20) and a torque of 1.3-1.5 Nm.

**NOTE!**

**Risk due to overtorque at the strain-relief device.**

Damage to the strain-relief device may result.

- ▶ Do not use a drill driver.

**IMPORTANT!**

Information for connection on the battery side can be found in the installation instructions from the relevant manufacturer.

**Connecting the LG FLEX ground conductor**

1

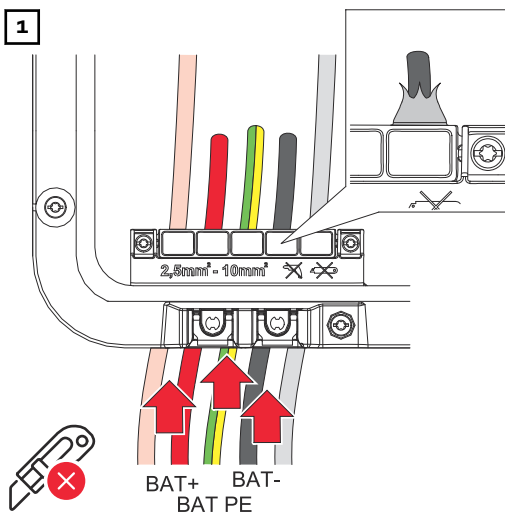

Push the ground conductor through the DC bushing by hand before stripping the insulation.

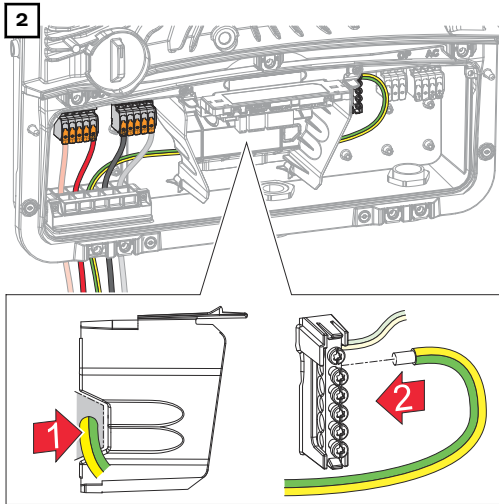

Place the battery ground conductor in the integrated cable duct of the connection area divider in the AC connection area. Fasten the battery ground conductor to the ground electrode terminal at the second input from above using a screwdriver (TX20) and a torque of 1.8-2 Nm.

**IMPORTANT!**

Information for connection on the battery side can be found in the installation instructions from the relevant manufacturer.

# Connecting backup power - PV Point (OP)

## Safety

### **WARNING!**

#### **Danger due to work that has been carried out incorrectly.**

This can result in serious injury and damage to property.

- ▶ Installing and connecting an option must only be carried out by service personnel trained by Fronius and only within the scope of the respective technical regulations.
- ▶ Follow the safety rules.

### **WARNING!**

#### **Danger due to damaged and/or contaminated terminals.**

This can result in serious injury and damage to property.

- ▶ Before making any connections, check the terminals for damage and contamination.
- ▶ Remove contamination in the de-energized state.
- ▶ Have defective terminals repaired by an authorized specialist.

### **NOTE!**

**During the switch from grid-connected operation to backup power mode, momentary interruptions will occur. The PV Point output requires PV power from the solar modules or a battery to power the connected loads.**

Connected loads will not be supplied with power during the switchover.

- ▶ Do not connect any loads that require an uninterruptible supply ( e.g., IT networks, life-sustaining medical devices).

### **IMPORTANT!**

The valid national laws, standards, and provisions, as well as the specifications of the relevant grid operator are to be taken into account and applied.

It is highly recommended that the specific installation be agreed with the grid operator and explicitly approved by this operator. This obligation applies to system constructors in particular (e.g., installers).

## Installation

### **NOTE!**

**All loads that have to be supplied via the OP terminal must be protected by means of a residual current circuit breaker.**

In order to ensure the residual current circuit breaker operates properly, a connection must be established between the neutral conductor N' (OP) and ground.

For the circuit diagram recommended by Fronius, see [Emergency power terminal —PV Point \(OP\)](#) on page 232.

1

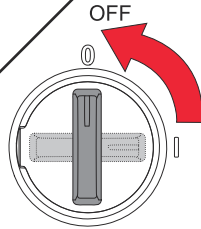
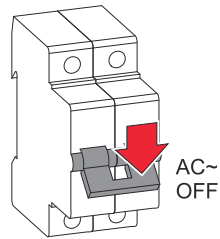

Switch off the automatic circuit breaker and DC disconnect. Turn the DC disconnect to the "off" switch setting.

2

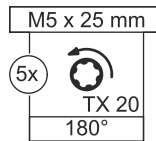
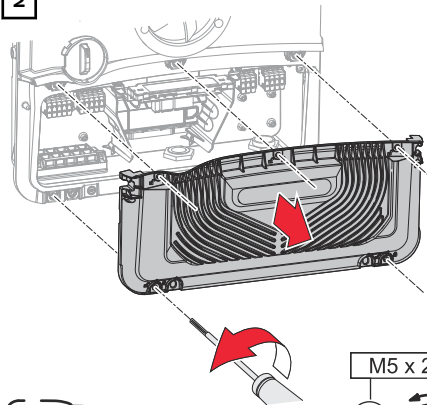

Loosen the 5 screws on the connection area cover by rotating them 180° to the left using a screwdriver (TX20). Remove the connection area cover from the device.

**⚠ CAUTION!**

**Danger from faulty or incorrect bores.**

This may lead to injuries to the eyes and hands as a result of flying debris and sharp edges, as well as damage to the inverter.

- ▶ When drilling, wear suitable protective goggles.
- ▶ Only use a step drill when drilling.
- ▶ Ensure that nothing on the inside of the device is damaged (e.g., the connection block).
- ▶ Adapt the diameter of the bore to match the corresponding connection.
- ▶ Deburr the bores using a suitable tool.
- ▶ Remove the drilling residues from the inverter.

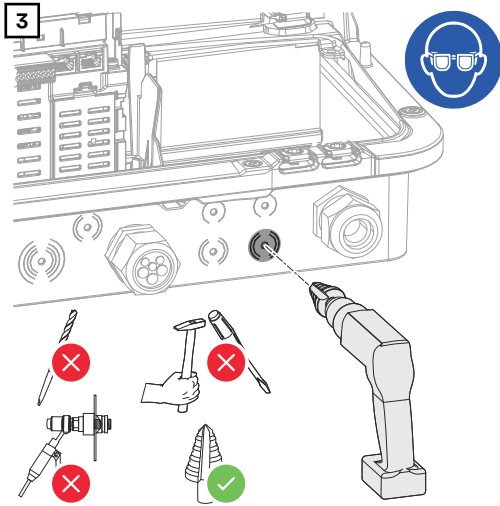

Drill out the optional cable guide with a step drill.

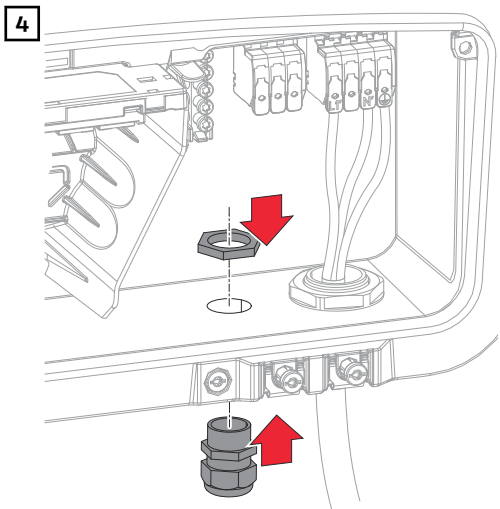

Insert the cable gland into the bore and fasten it using the torque specified by the manufacturer.

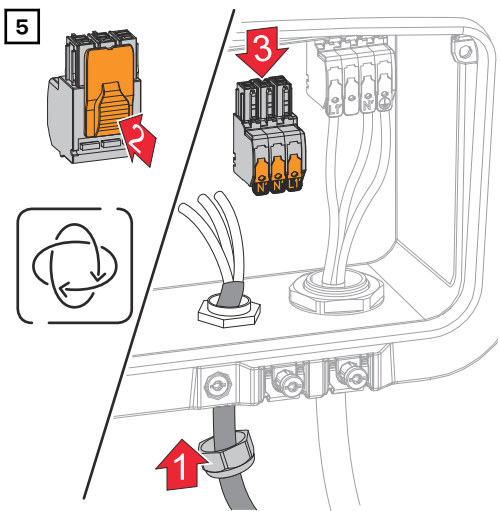

Guide the mains cable through the cable gland from below. Remove the OP terminal.

6

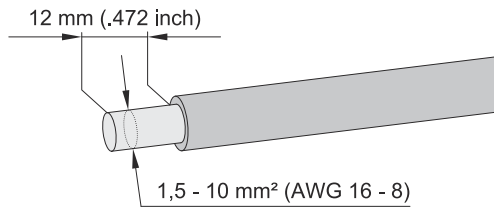

CU-Wire min:  
75° C / 167° F

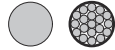

Strip the insulation of the single conductors by 12 mm. The cable cross-section must be between 1.5 mm<sup>2</sup> and 10 mm<sup>2</sup>. Lift to open the terminal's operating lever and insert the stripped single conductor into the slot provided, all the way up to the stop. Then close the operating lever until it engages.

**⚠ WARNING!**

**Danger from loose and/or incorrectly clamped single conductors in the terminal.**

This can result in serious injury and damage to property.

- ▶ Only connect one single conductor in the slot provided for each terminal.
- ▶ Check that the single conductors are secure in the terminal.
- ▶ Make sure that the single conductor has been fully inserted into the terminal and that no single wires are protruding out of the terminal.

7

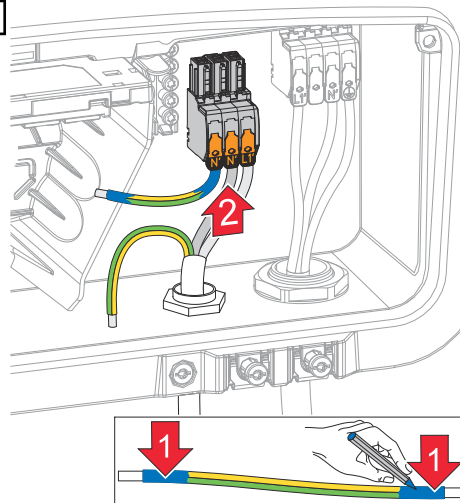

L1' Phase conductor  
N' Neutral conductor  
N' PEN conductor

**IMPORTANT!**

The PEN conductor must be produced with ends that are permanently marked blue, according to the national provisions, and have a cross-section of 10 mm<sup>2</sup>.

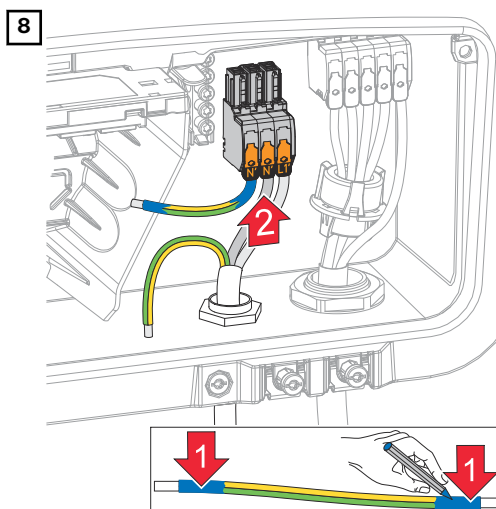

Fasten the ground conductor and PEN conductor to the ground electrode terminal using a screwdriver (TX20) and a torque of 1.8-2 Nm.

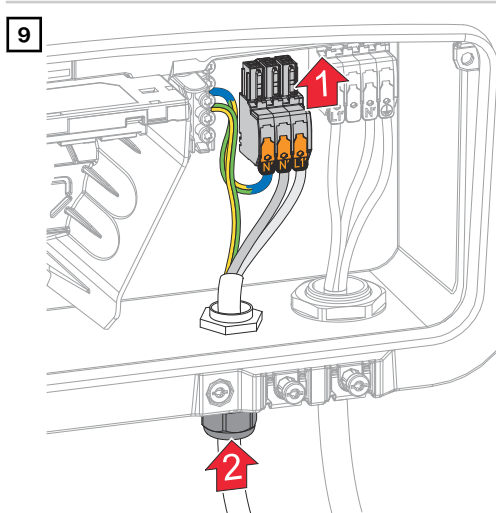

Insert the OP terminal into the OP slot until it engages. Tighten the union nut of the cable gland to the torque specified by the manufacturer.

### Testing backup power mode

Testing backup power mode is recommended:

- during first-time installation and configuration
- after working on the switch cabinet
- during ongoing operation (recommendation: at least every 6 months)

A battery charge of min. 30% is recommended for test mode.

A description of how to run the test mode can be found in the [checklist – Backup power](https://www.fronius.com/en/search-page) (https://www.fronius.com/en/search-page, item number: 42,0426,0365).

# Connecting backup power - Full Backup

## Safety



### WARNING!

#### **Danger from incorrect installation, commissioning, operation, or incorrect use.**

This can result in severe personal injury/damage to property.

- ▶ Only trained and qualified personnel are authorized to install and commission the system, and only within the scope of the technical regulations.
- ▶ The Installation and Operating Instructions must be read carefully prior to use.
- ▶ If anything is unclear, contact your vendor immediately.

#### **IMPORTANT!**

The valid national laws, standards, and provisions, as well as the specifications of the relevant grid operator are to be taken into account and applied.

It is highly recommended to coordinate the concrete examples implemented and in particular the specific installation with the grid operator to obtain their explicit approval. This obligation applies to system constructors in particular (e.g., installers).

The examples suggested here show a backup power supply with or without an external protection relay (external grid and system protection unit). The respective grid operator decides whether an external protection relay must be used or not.

#### **IMPORTANT!**

An uninterruptible power supply (UPS) may only be used to supply individual loads (e.g., computers). Feeding into the power supply of the house network is not permitted. The Installation and Operating Instructions must be read carefully prior to use. If anything is unclear, contact your vendor immediately.

The examples given in this document (in particular cabling variants and circuit diagrams) are suggestions only. These examples have been carefully developed and tested. They can therefore be used as a basis for real-life installation. Anyone following or using these examples does so at their own risk.

## **Automatic switch to backup power 1-pin single separation, e.g., Australia**

### **Circuit diagrams**

[Automatic switch to backup power 1-pin single FRT-capable separation](#) on page 242.

[Automatic switch to backup power 1-pin single separation - e.g., Australia](#) on page 243.

### **Cabling of the backup power circuits and non-backup power circuits:**

If not all the loads in the home need to be supplied in a backup power situation, the circuits need to be divided into backup power circuits and non-backup power circuits. The total load of the backup power circuits must not exceed the rated power of the inverter.

The backup power circuits and non-backup power circuits must be fused separately according to the required safety measures (e.g., residual current circuit breaker, automatic circuit breaker).

In backup power mode, only the backup power circuits are disconnected from the grid at 1 pin by contactor K1. In this case the rest of the home network is not supplied.

**The following points regarding cabling must be considered:**

- The main contacts of contactor K1 must be installed between the Fronius Smart Meter and the inverter or the residual current circuit breakers of the backup power circuits.
- The supply voltage for contactor K1 is provided by the public grid and must be connected to phase 1 (L1) downstream of the Fronius Smart Meter and fused accordingly.
- An NC contact for relay K3 interrupts the supply voltage to contactor K1. This prevents the backup power network of the inverter from being switched to the public grid.
- The NO contact of relay K3 gives feedback to the inverter that relay K3 has blocked the power.
- Additional inverters or other AC sources can be installed in the backup power circuit downstream of the main contacts of K1. The sources will not synchronize with the network of the inverter because this backup power network has a frequency of 53 Hz.

---

**Automatic switch to backup power 2-pole single disconnection e.g., Germany, France, UK, Spain**

**Circuit diagrams**

[Automatic switch to backup power 2-pin single separation - e.g., Germany](#) on page 244.

[Automatic switch to backup power 2-pin single separation - e.g., France](#) on page 245.

[Automatic switch to backup power 2-pin single separation - e.g., UK](#) on page 246.

[Automatic switch to backup power 2-pin single separation - e.g., Spain](#) on page 247.

**Cabling of the backup power circuits and non-backup power circuits:**

If not all the loads in the home need to be supplied in a backup power situation, the circuits need to be divided into backup power circuits and non-backup power circuits. The total load of the backup power circuits must not exceed the rated power of the inverter.

The backup power circuits and non-backup power circuits must be fused separately according to the required safety measures (e.g., residual current circuit breaker, automatic circuit breaker).

In backup power mode, only the backup power circuits are disconnected from the grid at all poles by contactor K1, and a ground connection is established for them. In this case the rest of the home network is not supplied.

**The following points regarding cabling must be considered:**

- The main contacts of contactor K1 must be installed between the Fronius Smart Meter and the residual current circuit breaker of the inverter or the residual current circuit breaker of the backup power circuits.
- The supply voltage for contactor K1 is provided by the public grid and must be connected to phase 1 (L1) downstream of the Fronius Smart Meter and fused accordingly.
- To ensure residual current circuit breakers function in backup power mode, the connection between the neutral conductor and the ground conductor must be established as close as possible to the inverter, but in any case upstream of the first residual current circuit breaker. An NC contact is used for this purpose for each of the main contacts of contactors K4 and K5. This ensures that the ground connection is established as soon as the public grid connection is no longer available.
- As with contactor K1, the supply voltage for contactors K4 and K5 is supplied via phase 1 (L1) of the public grid.
- An NC contact for relay K3 interrupts the supply voltage to contactors K1, K4, and K5. This prevents the ground connection from being immediately disconnected again when power returns to the public grid and the backup power network of the inverter from being switched to the public grid.
- The NO contact of relay K3 gives feedback to the inverter on whether relay K3 has blocked the power.
- Additional inverters or other AC sources can be installed in the backup power circuit downstream of the main contacts of K1. The sources will not synchronize with the network of the inverter because this backup power network has a frequency of 53 Hz.
- A Fronius Smart Meter with current transformer is required for the UK (e.g., Fronius Smart Meter 50kA-3 or Fronius Smart Meter TS 5kA-3).

---

**Automatic switch to backup power 2-pole double disconnection with ext. grid and system protection e.g., Italy**

**Circuit diagram**

[Automatic switch to backup power 2-pin double separation with ext. grid and system protection - e.g., Italy](#) on page 248.

**Cabling of the backup power circuits and non-backup power circuits:**

**IMPORTANT!**

For this circuit variant, the Fronius Smart Meter US-240 must be used.

The backup power circuits and non-backup power circuits must be fused separately according to the required safety measures (e.g., residual current circuit breaker, automatic circuit breaker).

In backup power mode, only the backup power circuits are disconnected from the grid by contactors K1 and K2, and a ground connection is established for them. In this case the rest of the home network is not supplied.

**The following points regarding cabling must be considered:**

- The main contacts of contactors K1 and K2 must be installed between the Fronius Smart Meter and the residual current circuit breaker of the inverter or the residual current circuit breakers of the backup power circuits.
- The supply voltage for contactors K1 and K2 is provided by the public grid and must be connected to phase 1 (L1) downstream of the Fronius Smart Meter and fused accordingly.
- Actuation of contactors K1 and K2 is carried out by the external grid and system protection.
- The external grid and system protection unit must be installed downstream of the Fronius Smart Meter. Detailed installation and wiring instructions for external grid and system protection units can be found in the unit's operating instructions.
- The remote trip input of the external grid and system protection unit must be set to NC according to the manufacturer's operating instructions.
- To ensure residual current circuit breakers function in backup power mode, the connection between the neutral conductor and the ground conductor must be established as close as possible to the inverter, but in any case upstream of the first residual current circuit breaker. An NC contact is used for this purpose for the main contacts of contactors K4 and K5. This ensures that the ground connection is established as soon as the public grid connection is no longer available.
- The supply voltage for the contactors K1, K2, K4, and K5 is supplied via phase 1 (L1) of the public grid and is switched via the external grid and system protection unit.
- An NC contact for relay K3, which activates the remote input of the external grid and system protection unit, interrupts the supply voltage to contactors K1, K2, K4, and K5. This prevents the ground connection from being immediately disconnected again when power returns to the public grid and the backup power network of the inverter from being switched to the public grid.
- The NO contact of relay K3 gives additional feedback to the inverter on whether relay K3 has blocked the power.
- Additional inverters or other AC sources can be installed in the backup power circuit downstream of the main contacts of K1 and K2. The sources will not synchronize with the network of the inverter because this backup power network has a frequency of 53 Hz.

---

**Manual switch to backup power 1-pole disconnection e.g., Australia / 2-pole disconnection e.g., Germany**

**Circuit diagrams**

[Manual switch to backup power 1-pin separation, e.g., Australia](#) on page 252.

[Manual switch to backup power 2-pin separation, e.g., Germany](#) on page 253.

**IMPORTANT!**

The circuit diagrams to be used must be applied in line with the country standard and the implementing regulations of the utility.

**Cabling of the backup power circuits and non-backup power circuits:**

If not all the loads in the home need to be supplied in a backup power situation, the circuits need to be divided into backup power circuits and non-backup power circuits. The total load of the backup power circuits must not exceed the rated power of the inverter.

The backup power circuits and non-backup power circuits must be fused separately according to the required safety measures (e.g., residual current circuit breaker, automatic circuit breaker).

In backup power mode, only the backup power circuits and the inverter are disconnected from the grid by changeover switch Q1. In the case of 2-pole disconnection, a ground connection is also established. In this case, the loads in the non-backup power circuits are not supplied by the inverter.

**The following points regarding installation must be considered:**

- The changeover switch Q1 must be dimensioned for the fuses installed upstream, the max. occurring amperage, and the max. occurring short circuit current. An auxiliary switching element with 2 NO contacts is required for switch position 1 (grid operation) to match the installed changeover switch Q1.  
The changeover switch Q1 used must fulfil a short-circuit breaking capacity of at least 10 kA according to standard IEC 60947-1. If the short circuit current at the installation point reaches a value above 10 kA, a switch with a corresponding short-circuit breaking capacity must be used.
- The circuitry is only to be used in household-like applications and systems (small businesses and agriculture) or up to upstream fuses with a nominal current of 63 A.
- Min. impulse withstand voltage of the changeover switch of 4 kV according to IEC 60947-1.
- It must be clarified with the utility whether the 1-pole or 2-pole disconnection must be used.
- The protective measure must be tested regularly; if this is not regulated by law, it must be performed annually.
- Data transfer between the Fronius Smart Meter and the inverter may be interrupted in backup power mode (switch position 2). This is optionally ensured via a contact of the changeover switch. Interrupting the Smart Meter connection is optional and prevents the backup power function from ending when power returns to the public grid. If this does not take place, the inverter interrupts the backup power supply when power returns to the public grid. Failure to manually switch to parallel grid mode within the first 10 minutes of the power returning to the public grid may cause the inverter and battery to shut down. In this case, a manual system start must be carried out (see chapter [Manual system start](#) on page 31). This behavior must be taken into account especially during a test of manual switching, because the inverter does not start backup power mode when there is a grid connection due to Smart Meter data being available.
- The data communication connection with the Fronius Smart Meter must be established separately from the battery to its dedicated Modbus input so that battery data communication is maintained (see chapter [Modbus participants](#) on page 97).
- Feedback to the digital inputs (IOs) of the inverter via the changeover switch Q1 (switch position 2) is a starting condition for the inverter's backup power mode.
- The AC output of the inverter is de-energized when switching via switch position 0. This is ensured by interrupting the WSD line with 2 contacts of the changeover switch Q1 in position 0.
- The continuous connection between the equipotential bonding rail and the neutral conductor from the inverter must not be interrupted in the case of 1-pole disconnection.
- In the case of 2-pole disconnection, the PE-N conductor connection is made via the main contacts of changeover switch Q1 in duplicate.
- Additional inverters or other AC sources can be installed in the backup power circuit downstream of the changeover switch Q1. The sources will not synchronize with the backup power network of the inverter in a backup power situation because this is operated at 53 Hz.

---

**Testing backup power mode**

Testing backup power mode is recommended:

- during first-time installation and configuration
- after working on the switch cabinet
- during ongoing operation (recommendation: at least every 6 months)

A battery charge of min. 30% is recommended for test mode.

A description of how to run the test mode can be found in the [checklist – Backup power](https://www.fronius.com/en/search-page) (https://www.fronius.com/en/search-page, item number: 42,0426,0365).

# Connecting the data communication cables

## Modbus participants

The inputs M0 and M1 can be freely selected. A maximum of four Modbus participants can be connected to the Modbus terminal at inputs M0 and M1.

### IMPORTANT!

Only one primary meter, one battery, and one Ohmpilot can be connected per inverter. Due to the high data transfer of the battery, the battery occupies two subscribers. If the **Inverter Control via Modbus** function is activated in the **Communication > Modbus** menu area, no Modbus participants are possible. It is not possible to send and receive data at the same time.

### Example 1:

Input	Battery	Fronius Ohmpilot	Number of primary meters	Number of secondary meters
Modbus 0 (M0)	✗	✗	0	4
	✓	✗	0	2
	✓	✓	0	1
Modbus 1 (M1)	✗	✗	1	3

### Example 2:

Input	Battery	Fronius Ohmpilot	Number of primary meters	Number of secondary meters
Modbus 0 (M0)	✗	✗	1	3
Modbus 1 (M1)	✗	✗	0	4
	✓	✗	0	2
	✓	✓	0	1

## Routing data communication cables

### IMPORTANT!

If data communication cables are wired into the inverter, observe the following points:

- Depending on the number and cross-section of the wired data communication cables, remove the corresponding blanking plugs from the sealing insert and insert the data communication cables.
- Make sure that you insert the corresponding blanking plugs into any free openings on the sealing insert.

**IMPORTANT!**

Safety class IP 66 cannot be ensured if blanking plugs are missing or incorrectly inserted.

**1**

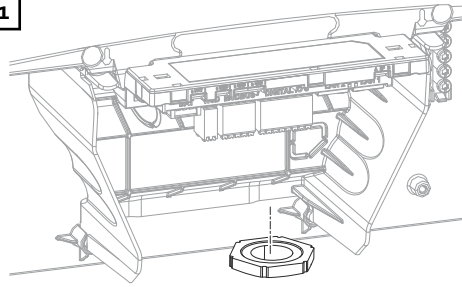

Remove the union nut on the cable gland and press the sealing ring with the blanking plugs out from the inside of the device.

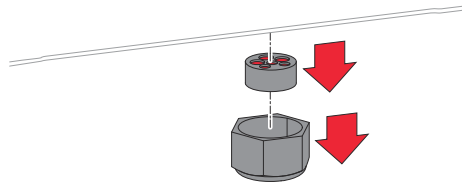

**2**

3x Ø 4,9 - 5,5 mm (.193 - .217 inch)  
3x Ø 6,7 - 8,5 mm (.264 - .335 inch)

Open up the sealing ring at the location where the blanking plugs are to be removed.

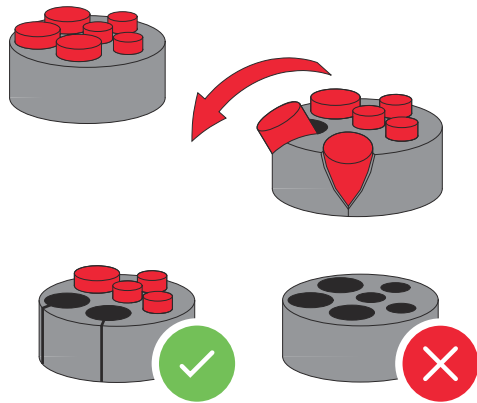

\* Remove the blanking plugs with a sideways motion.

**3**

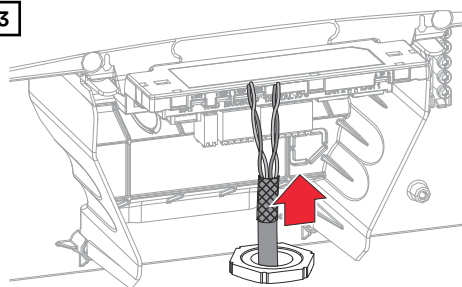

First, guide the data cables through the union nut of the cable gland and then through the housing opening.

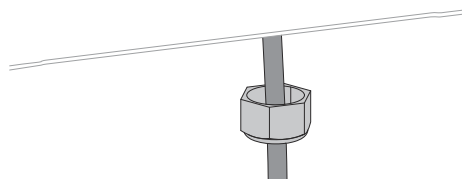

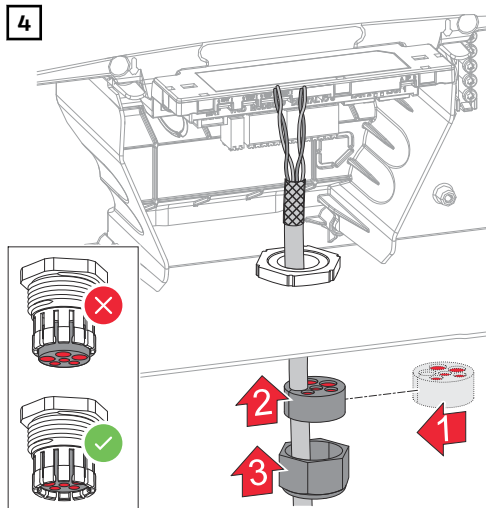

Insert the sealing ring between the union nut and the housing opening. Press the data cables into the seal's cable guide. Then press in the seal until it reaches the underside of the cable gland.

### Connecting the battery communication cable

#### Modbus RJ45

#### IMPORTANT!

For this connection version, the BAT switch on the data communication area must be in position 1.

#### NOTE!

#### Power supply

Voltage is present at the connection. If network devices (e.g., WiFi routers) are connected, the device may be damaged.

- ▶ Only connect batteries to the battery connection

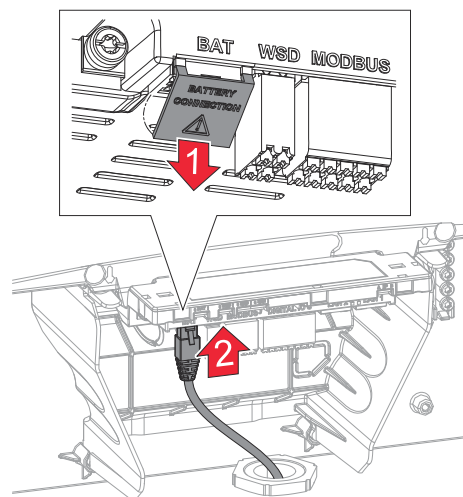

- 1 Knock out the protective cover
- 2 Connect the cable to the RJ45 socket

- ✓ The LEDs on the RJ45 socket light up red when the battery connection is active.

#### Modbus terminal

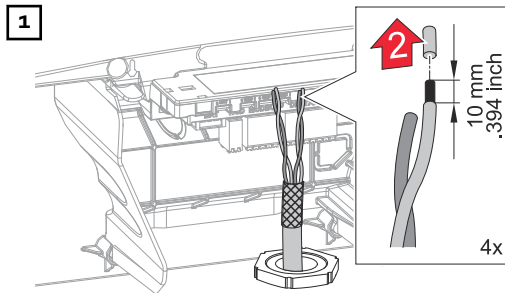

Strip 10 mm of insulation from the single conductors and fit the ferrules if necessary.

**IMPORTANT!**

If several single conductors are connected to an input of the push-in terminals, connect the single conductors with a corresponding ferrule.

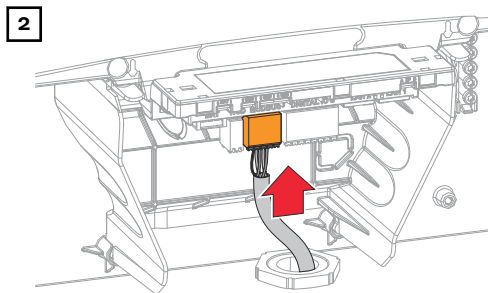
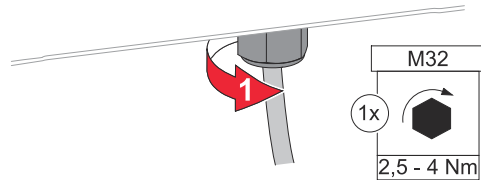

Insert the cables into the respective slot and check the cables are securely retained.

**IMPORTANT!**

Use a twisted cable pair for data cables that belong together.

Twist the cable shield and insert into the "SHIELD" slot.

Modbus		Battery	Modbus
GND	V+		M0+
M0-	M0+		M0-
SHIELD	SHIELD		GND
M1-	M1+		V+
GND	V+		Shield

**IMPORTANT!**

Improperly fitted shielding can cause data communication problems.

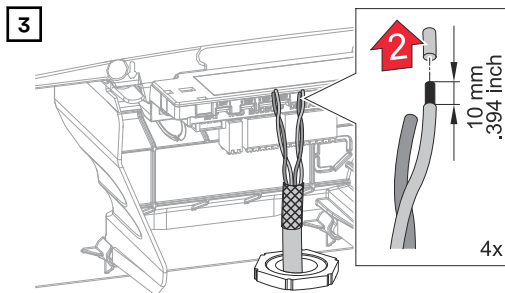

Fasten the union nut of the cable gland with a torque of min. 2.5 - max. 4 Nm.

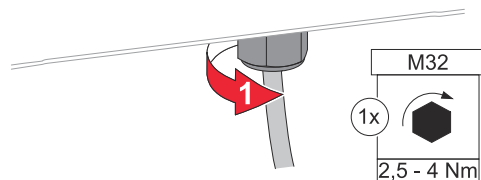

For the circuit diagram recommended by Fronius, see [System circuit diagrams](#) on page 219.

**Terminating resistors**

It may be possible for the system to function without terminating resistors. However, owing to interference, the use of terminating resistors according to the following overview is recommended for trouble-free operation.

For permissible cables and max. distances for the data communication area, refer to the chapter headed [Permitted cables for the data communication connection](#) on page 69.

**IMPORTANT!**

Terminating resistors that are not positioned as illustrated can result in interference in the data communication.

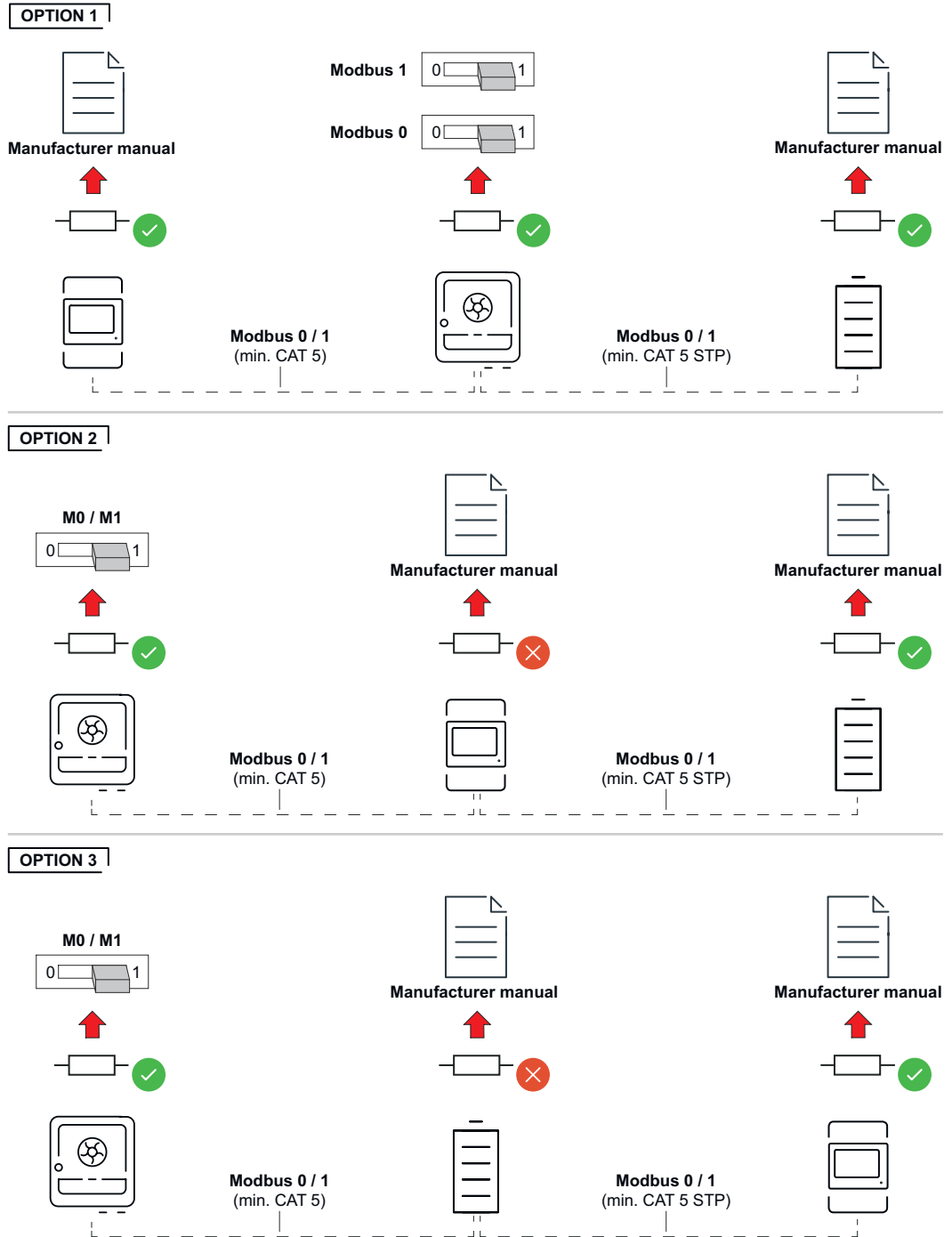

**Installing the WSD (wired shutdown)**

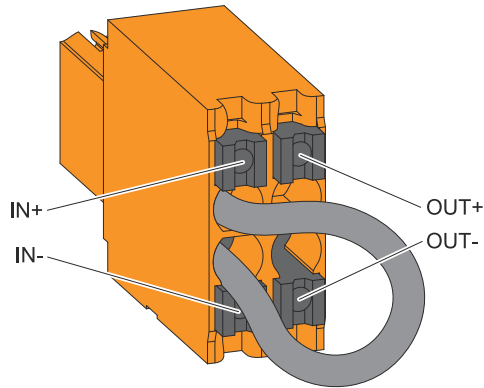

**IMPORTANT!**

The push-in WSD terminal in the inverter's connection area is delivered with a bypass ex works as standard. The bypass must be removed when installing a trigger device or a WSD chain.

The WSD switch of the first inverter with connected trigger device in the WSD chain must be in position 1 (master). The WSD switch of all other inverters should be in position 0 (secondary device).

Max. distance between 2 devices: 100 m  
Max. Number of devices: 28

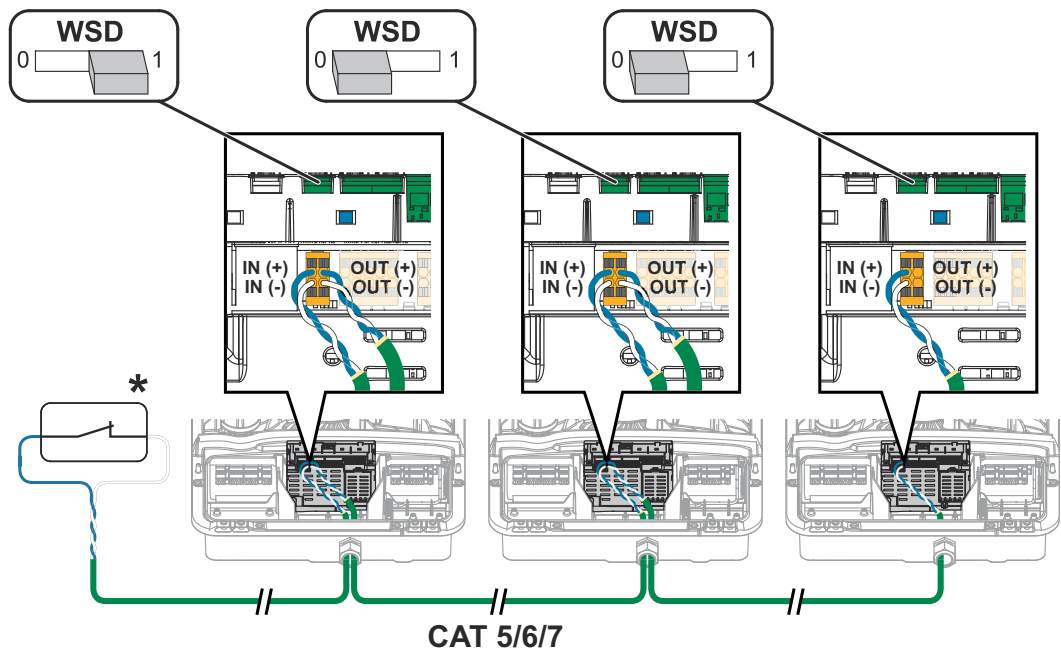

\* Floating contact of the trigger device (e.g., central grid and system protection). If several floating contacts are used in a WSD chain, these must be connected in series.

# Closing and commissioning the inverter

## Closing the inverter's connection area/housing cover, and commissioning

### NOTE!

The housing cover is fitted with a lock for safety reasons, which allows the housing cover on the inverter to be pivoted only when the DC disconnecter is off.

- ▶ Only clip and pivot the housing cover into the inverter when the **DC disconnecter is switched off**.
- ▶ Do not use excessive force to clip in and pivot the housing cover.

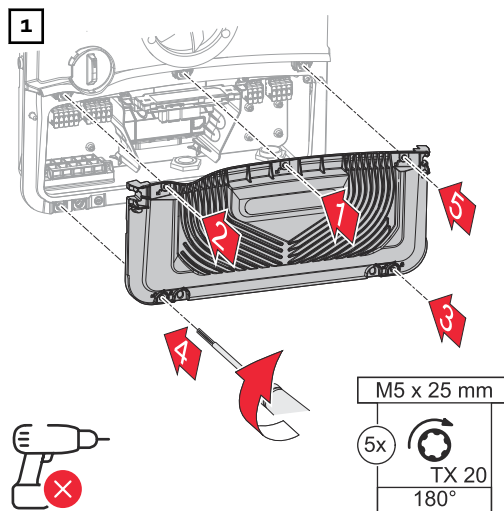

Place the cover on the connection area. Tighten the 5 screws by rotating them 180° to the right in the indicated order using a screwdriver (TX20).

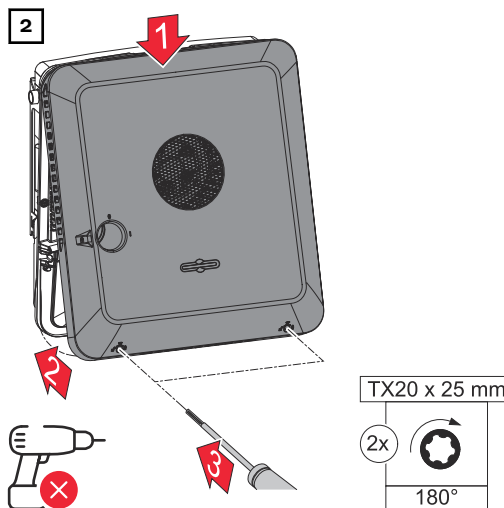

Clip the housing cover into the inverter from above.

Press on the lower part of the housing cover and tighten the 2 screws by rotating them 180° to the right using a screwdriver (TX20).

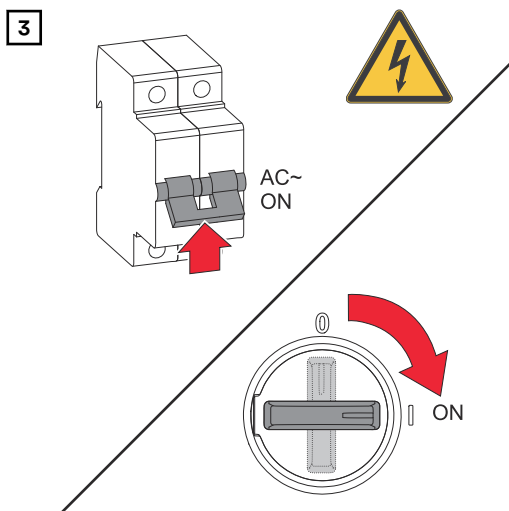

Turn the DC disconnect to the "on" switch setting. Turn on the automatic circuit breaker. For systems with a battery, observe the switch-on sequence according to the chapter [Button functions and LED status indicator](#) on page 27.

**IMPORTANT!** Open the WiFi access point with the optical sensor, see chapter [Suitable batteries](#) on page 37

### Starting the inverter for the first time

When starting the inverter for the first time, various setup settings must be configured.

If the setup is canceled before completion, the input data is not saved and the start screen with the installation wizard is shown once again. The data is saved in the event of an interruption, e.g., a power failure. Commissioning is continued at the point at which the interruption occurred after the power supply is restored. If the setup was interrupted, the inverter feeds energy into the grid at maximum 500 W and the operating status LED flashes yellow.

The country setup can only be set when starting the inverter for the first time. If the country setup needs to be changed at a later date, contact your installer/technical support.

### Installation with the app

The Fronius Solar.start app is required for installation. Depending on the mobile device used to perform the installation, the app is available on the relevant platform.

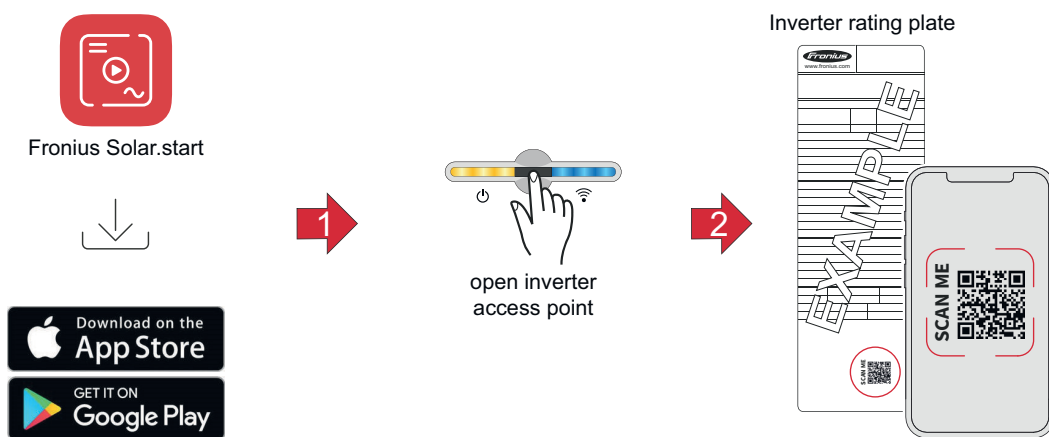

- 1 Download and install the Fronius Solar.start app.
- 2 Open the access point by touching the sensor .
  - ✓ *Communication LED flashes blue.*
- 3 Open the Fronius Solar.start app and follow the installation wizard. Scan the QR code on the rating plate with a smartphone or tablet to connect to the inverter.

- 4 Add system components in Fronius Solar.web and commission the PV system.

The network wizard and product setup can be performed independently. A network connection is required for the Fronius Solar.web installation wizard.

## Installation with the browser

### WLAN:

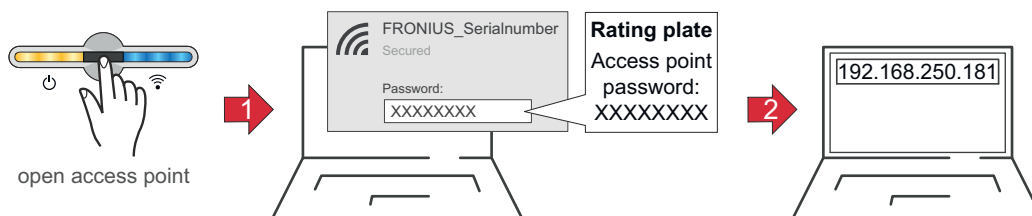

- 1 Open the access point by touching the sensor
  - ✓ *Communications LED flashes blue.*
- 2 Establish the connection to the inverter in the network settings (the inverter is displayed with the name "FRONIUS\_" and the serial number of the device).
- 3 Enter the password from the rating plate and confirm.
 

**IMPORTANT!**

To enter the password in Windows 10, first select the **Connect using a security key instead** link to be able to establish the connection with the password.
- 4 Enter the IP address 192.168.250.181 in the address bar of the browser and confirm. The installation wizard opens.
- 5 Follow the installation wizard and complete the installation in the individual areas.
- 6 Add the system components in Fronius Solar.web and commission the PV system.

The network wizard and product setup can be performed independently. A network connection is required for the Fronius Solar.web installation wizard.

### Ethernet:

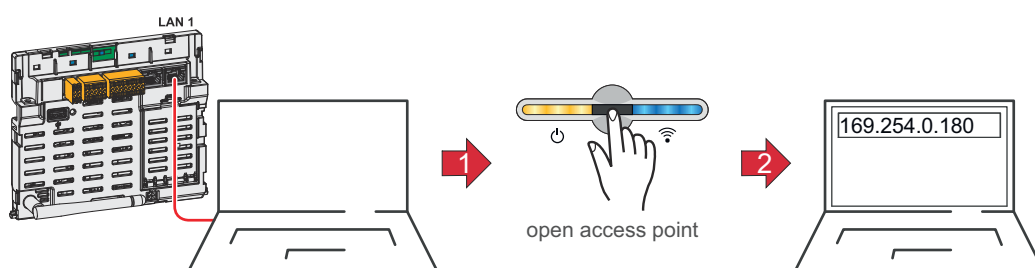

- 1 Establish a connection to the inverter (LAN1) using a network cable (min. CAT5 STP).
- 2 Open the access point by touching the sensor once
  - ✓ *Communications LED flashes blue.*
- 3 Enter the IP address 169.254.0.180 in the address bar of the browser and confirm. The installation wizard opens.
- 4 Follow the installation wizard and complete the installation in the individual areas.
- 5 Add the system components in Fronius Solar.web and commission the PV system.

The network wizard and product setup can be performed independently. A network connection is required for the Fronius Solar.web installation wizard.

# De-energizing the inverter and switching it back on

**De-energizing the inverter and switching it back on**

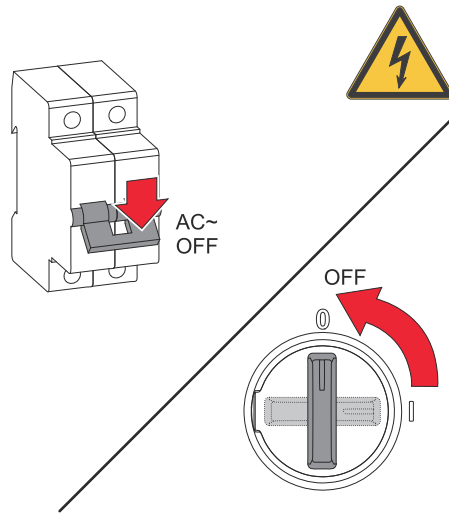

**Disconnecting the inverter from the power supply:**

- 1 Turn off the automatic circuit breaker.
- 2 Turn the DC disconnecter to the "off" switch setting.

**IMPORTANT!**

Wait for the capacitors of the inverter to discharge!

**Switching on the inverter:**

If the inverter has not been in operation for six months or more after installation, it must be tested before commissioning.

- 1 Turn the DC disconnecter to the "on" switch setting.
- 2 Turn on the automatic circuit breaker.



# **Settings – User interface of the in- verter**



# User settings

---

## User login

- 1 Open the user interface of the inverter in the browser.
- 2 In the **Login** menu area, log in with username and password, or, in the **User > User Login** menu area, log in with username and password.

### **IMPORTANT!**

Depending on the authorization of the user, settings can be made in the individual menu areas.

---

## Selecting languages

- 1 In the **User > Language** menu area, select the desired language.

# Device configuration

## Components

All available components of the system can be added via **Add component+**.

### PV Generator

Activate the MPP tracker and enter the connected PV output in the relevant field. In the case of combined solar module strings, **PV 1 + PV 2 connected in parallel** must be activated.

### Meter

#### Primary meter

##### IMPORTANT!

For problem-free operation with further energy generators and in Full Backup power mode, it is important to install and configure a Fronius Smart Meter as the **primary meter** at the feed-in point. The inverter and further generators must be connected to the public grid via the Fronius Smart Meter. Only one **primary meter** can be configured in the system.

This setting has an effect on the behavior of the inverter during the night. If the **primary meter** has been configured, the inverter remains permanently connected to the grid in order to enable it to draw energy from other generators at any time.

If the **primary meter** has not been configured, the inverter switches to standby mode as soon as there is no more PV power available. No energy management specification is sent to the battery (e.g., minimum state of charge reached). The message "Power low" is displayed. The inverter starts again as soon as an energy management specification is sent or sufficient PV power is available.

#### Secondary meter

In addition to the **primary meter**, further **secondary meters** can be added to the system to record the load curves of individual loads and generators (e.g., heat pump, wind power plant, etc.) and provide the measured data for energy profiling in Fronius Solar.web.

1. After connecting the meter, select a category:
  - **Primary meter**
  - **Secondary meter**
2. Select one of the following device types:
  - **Modbus RTU**
  - **Modbus TCP**
  - **MQTT** (available **MQTT device** is displayed automatically)

#### NOTE!

For communication via MQTT and Modbus TCP, install the inverter and Smart Meter in the same sub-network.

3. Additionally define the following parameters for the Smart Meter:
  - **Application** of primary meter (**Feed-in point** or **Load branch**)
  - **Application** of secondary meter (**Production meter** or **Secondary meter**)
  - **Name**
  - **Category** (e.g., **inverter, heat pump**)
  - **IP Address** (for Modbus TCP)
  - **Port** (for Modbus TCP)
  - **Modbus Address** (for Modbus RTU and TCP)

The Watt value for the production meter is the sum of all production meters. The Watt value for the secondary meter is the sum of all secondary meters.

---

### **Battery**

If the **SoC Limit Mode** is set to **Auto**, the values **SoC Minimum** and **SoC Maximum** are preset according to the technical specifications of the battery manufacturer.

If the **SoC Limit Mode** is set to **Manual**, the values **SoC Minimum** and **SoC Maximum** can be changed after consultation with the battery manufacturer within the framework of their technical specifications. In a backup power situation, the set values are not taken into account.

The setting **Allow battery charging from other generators in the home network** activates/deactivates charging of the battery from other generators. The power consumption of the Fronius inverter can be restricted by specifying a value in the **Max. Charging Power from AC** field. As a maximum, a power consumption equal to the AC rated power of the Fronius inverter is possible.

The setting **Allow battery charging from public grid + Allow battery charging from other generators in the home network** activates/deactivates the charging of the battery from the public grid and, if present, from other generators in the home network.

The normative or compensatory specifications must be taken into account for this setting. Irrespective of this setting, necessary service-related charging from the public grid is performed (e.g., forced re-charging to protect against deep discharge).

### **IMPORTANT!**

Fronius accepts no liability for damage to third-party batteries.

---

### **Ohmpilot**

All the Ohmpilots available in the system are displayed. Select the desired Ohmpilot and add to the system via **Add**.

---

## **Functions and I/Os**

### **Backup Power**

In backup power mode, it is possible to select between **Off**, **PV Point**, and **Full Backup**.

The backup power mode **Full Backup** can only be activated once the required I/O assignments for backup power have been configured. In addition, a meter must be installed and configured at the feed-in point for the backup power mode **Full Backup**.

### **IMPORTANT!**

When configuring the backup power mode **PV Point**, the instructions in chapter [Safety](#) on page [86](#) must be observed.

When configuring the backup power mode **Full Backup**, the instructions in chapter [Safety](#) on page [91](#) must be observed.

### **Backup Nominal Voltage**

When backup power mode is activated, the nominal voltage of the public grid must be selected.

### **SoC warning level**

In backup power mode, a warning is emitted when this residual battery capacity is reached.

### **Reserve Capacity**

The set value results in a residual capacity (depending on the capacity of the bat-

tery) that is reserved for backup power situations. The battery is not discharged below the residual capacity in grid connected mode. In backup power mode, the manually set value of **SoC Minimum** is not taken into account. If there is a backup power situation, the battery is always discharged up to the automatically preset, minimum SoC according to the technical specifications of the battery manufacturer.

### System preservation during night

To ensure continuous backup power operation even during the night, the inverter calculates a reserve capacity for system preservation depending on the battery capacity. When the calculated limit value is reached, standby mode is activated for the inverter and the battery and maintained for a period of 16 hours. Connected loads are no longer supplied. The battery is discharged up to the preset minimum SoC.

### Load Management

Up to four pins for the load management can be selected here. Further settings for the load management are available in the **Load Management** menu item.  
Default: Pin 1

### Australia - Demand Response Modes (DRM)

The pins for control via DRM can be set here:

Mode	Description	Information	DRM Pin	I/O Pin
DRM0	Inverter disconnects from the grid	DRM0 occurs in the event of an interruption or short circuit on the REF GEN or COM LOAD lines, or in the event of invalid combinations of DRM1 - DRM8. The grid relays open.	REF GEN COM LOAD	IO4 IO5
DRM1	Import $P_{nom} \leq 0\%$ without disconnection from grid	currently not supported	DRM 1/5	IN6
DRM2	Import $P_{nom} \leq 50\%$	currently not supported	DRM 2/6	IN7
DRM3	Import $P_{nom} \leq 75\%$ & $+Q_{rel}^* \geq 0\%$	currently not supported	DRM 3/7	IN8
DRM4	Import $P_{nom} \leq 100\%$	currently not supported	DRM 4/8	IN9
DRM5	Export $P_{nom} \leq 0\%$ without disconnection from grid	currently not supported	DRM 1/5	IN6
DRM6	Export $P_{nom} \leq 50\%$	currently not supported	DRM 2/6	IN7
DRM7	Export $P_{nom} \leq 75\%$ & $-Q_{rel}^* \geq 0\%$	currently not supported	DRM 3/7	IN8
DRM8	Export $P_{nom} \leq 100\%$	currently not supported	DRM 4/8	IN9

The percentage specifications always relate to the rated device power.

### IMPORTANT!

If the **Australia - Demand Response Modes (DRM)** function is activated and no DRM control is connected, the inverter switches to standby mode.

---

## Demand Response Modes (DRM)

Here you can enter a value for the apparent power input and the apparent power output for the Australia country setup.

---

## Inverter

### Enforce Standby

When this function is activated, grid power feed operation of the inverter is interrupted. This makes it possible to shut down the inverter without power and protect its components. The standby function is automatically deactivated when the inverter is restarted.

---

### Fan test

#### IMPORTANT!

To view and change settings in this menu item, select the user **Technician**, and enter and confirm the password for the user **Technician**. Settings may only be made by trained and qualified personnel.

This function can be used to check whether the fans of the inverter are working correctly based on acoustics, for example after replacing a fan.

#### 1 Click **Start fan test**

- ✓ *The inverter successively activates all fans that are running at partial load during the test phase to avoid unnecessary noise. The inverter is in standby during this time.*

The test takes around 30 seconds per fan. The inverter then switches back to normal operation. The test can be stopped manually using the **Stop fan test** function.

---

### PV 1 and PV 2

Parameter	Value range	Description
<b>Mode</b>	Off	The MPP tracker is deactivated.
	Auto	The inverter uses the voltage at which the maximum possible output of the MPP tracker is possible.
	Fixed	The MPP tracker uses the voltage defined in <b>UDC fixed</b> .
<b>UDC fixed</b>	80 - 530 V	The inverter uses the fixed voltage that is used on the MPP tracker.
<b>Dynamic Peak Manager</b>	Off	Function is deactivated.
	On	The entire solar module string is checked for optimization potential and the best possible voltage for grid power feed operation is determined.
	On (MLSD)	The function is optimized for systems with Module Level Shutdown devices (MLSD) and is not suitable for PV optimizers.

---

### Ripple Control

Ripple control signals are signals that are sent by the energy company in order to switch controllable loads on and off. Depending on the installation situation,

ripple control signals can be dampened or amplified by the inverter. This can be counteracted if necessary by applying the following settings.

Parameter	Value range	Description
<b>Reduction of influence</b>	Off	Function is deactivated.
	On	Function is activated.
<b>Frequency of the ripple control signal</b>	100 - 3000 Hz	The frequency specified by the energy company must be entered here.
<b>Grid inductance</b>	0.00001 - 0.005 H	The value measured at the feed-in point must be entered here.

#### Measures to prevent FI/RCMU false alarms

(when using a 30 mA residual current circuit breaker)

#### NOTE!

**A residual current circuit breaker for the AC connecting cable may be required depending on national regulations, the grid operator, and other conditions.**

A type A residual current circuit breaker is generally sufficient in this case. Nevertheless, false alarms can be triggered for the type A residual current circuit breaker in individual cases and depending on local conditions. For this reason, Fronius recommends using a residual current circuit breaker suitable for frequency inverters with a release current of least 100 mA, taking into account national provisions.

Parameter	Value range	Description
<b>Leakage current factor to reduce RCMU/FI false tripping</b>	0 - 0.25 (default: 0.16)	By reducing the setting value, the leakage current is reduced and the intermediate circuit voltage is increased, which slightly lowers the efficiency. <ul style="list-style-type: none"> <li>- A set value of 0.16 ensures optimum efficiency.</li> <li>- A setting value of 0 enables minimum leakage currents.</li> </ul>
<b>Shutdown before 30 mA RCD triggers</b>	Off	The function for reducing false tripping of the residual current circuit breaker is deactivated.
	On	The function for reducing false tripping of the residual current circuit breaker is activated.
<b>Rated non-tripping fault current limit value</b>	0.015 - 0.3	Value of the non-tripping residual current specified by the manufacturer for the residual current circuit breaker at which the residual current circuit breaker does not switch off under specified conditions.

## Insulation warning

Parameter	Value range	Description
<b>Insulation warning</b>	Off	The insulation warning is deactivated.
	On	The insulation warning is activated. A warning is output in the event of an insulation fault.
<b>Insulation measurement mode</b>	Exact	Insulation monitoring takes place with the highest degree of accuracy and the measured insulation resistance is displayed on the user interface of the inverter.
	Fast	Insulation monitoring takes place with a lesser degree of accuracy, whereby the time to take the insulation measurement is shortened and the insulation value is not displayed on the user interface of the inverter.
<b>Threshold for the insulation warning</b>	100,000 - 10,000,000	If the value drops below the threshold, status code 1083 is displayed on the user interface of the inverter.

## Backup power

Parameter	Value range	Description
<b>Backup power nominal voltage</b>	220 - 240 V	The nominal phase voltage that is output in backup power mode.
<b>Backup power frequency offset</b>	-5 to +5 Hz	The setting value can be used to reduce or increase the backup power frequency (see <a href="#">Technical data</a> ) by the offset value. The default value is +3 Hz. Connected loads (e.g., Fronius Ohmpilot) detect active backup power mode based on the change in frequency and react accordingly (e.g., activation of energy-saving mode).  <b>IMPORTANT!</b> If another AC source is available in the system, the backup power frequency must not be changed. The default value (+3 Hz) prevents other AC sources from feeding in parallel to the inverter in backup power mode and triggering power surges as well as shutting down the dedicated backup power network.
<b>Backup power undervoltage protection limit value <math>U_{&lt;}</math> [pu]</b>	0 - 2 %V	This setting value represents the limit value for shutting down backup power mode e.g., setting value 0.9 = 90% of the nominal voltage.
<b>Backup power undervoltage protection time <math>U_{&lt;}</math></b>	0.04 - 20 s	Trip time for falling below the backup power undervoltage protection limit value.

Parameter	Value range	Description
<b>Backup power surge protection limit value U&gt; [pu]</b>	0 - 2 %V	This setting value represents the limit value for shutting down backup power mode e.g., setting value 1.1 = 110% of the nominal voltage.
<b>Backup power surge protection time U&gt;</b>	0.04 - 20 s	Trip time for exceeding the backup power surge protection limit value.
<b>Fast undervoltage protection / ground fault protection limit value U&lt;&lt; [pu]</b>	0-100%V	Defines the voltage limit value below which rapid undervoltage protection or protection against ground faults is triggered. Typically, a value such as 0.3 pu (30% of the nominal voltage) is set here.
<b>Fast undervoltage protection / ground fault protection time U&lt;&lt;</b>	0 - 10 s	Defines the maximum time (in seconds) for which the voltage may be below the set limit value before the inverter switches off. This value must be $\leq 0.4$ s in accordance with ÖVE E 8101.
<b>Backup power restart delay</b>	0 - 600 s	Waiting time for restarting backup power mode following a shutdown.
<b>Backup power restart attempts</b>	1 - 10	The max. number of automated restart attempts. Once the max. number of automated restart attempts has been reached, service message 1177 must be manually acknowledged.
<b>External frequency monitoring in backup power mode (only for Italy)</b>	Off	Function is deactivated
	On	For Full Backup power mode in Italy, external frequency monitoring must be activated. The mains frequency is checked before ending backup power mode. If the mains frequency is within the permitted limits, the loads are connected to the public grid.
<b>Backup power short circuit switch-off time</b>	0.001 - 60 s	If a short circuit occurs during backup power mode, backup power mode is interrupted within the set time.

# Energy management

---

## Permitted maximum battery charge from the public grid

In Germany, new rules for charging batteries came into force on January 1, 2024. The maximum charging power from public grids is 4.2 kW when controlled in accordance with Section 14a of the EnWG (Energy Industry Act). The inverter must establish a connection to Fronius Solar.web for documentation purposes and be permanently connected to the Internet in order to be able to prove the implementation of the external control commands. The charging power is limited to a value below this by default. It is important not to use more than the allowed 4.2 kW charging power.

---

## Battery management

### State of charge settings

If the **SoC Limit Mode** is set to **Auto**, the values **SoC Minimum** and **SoC Maximum** are preset according to the technical specifications of the battery manufacturer.

If the **SoC Limit Mode** is set to **Manual**, the values **SoC Minimum** and **SoC Maximum** can be changed after consultation with the battery manufacturer within the framework of their technical specifications. In a backup power situation, the set values are not taken into account.

If **Battery charging from other sources** is activated, the following options are available:

- The setting **From other generators in the home network and from public grid** activates/deactivates the charging of the battery from the public grid and, if present, from other generators in the home network. The normative or compensatory specifications must be taken into account for this setting. Irrespective of this setting, necessary service-related charging from the public grid is performed (e.g., forced re-charging to protect against deep discharge).
- The setting **From other generators in the home network** activates/deactivates charging of the battery from other generators. The power consumption of the Fronius inverter can be restricted by specifying a value in the **Max. Charging Power from AC** field. As a maximum, a power consumption equal to the AC rated power of the Fronius inverter is possible.

### SoC warning level

In backup power mode, a warning is emitted when this residual battery capacity is reached.

### Reserve Capacity

The set value results in a residual capacity (depending on the capacity of the battery) that is reserved for backup power situations. The battery is not discharged below the residual capacity in grid connected mode.

### IMPORTANT!

Fronius accepts no liability for damage to third-party batteries.

---

### Time-dependent battery control

Using the Time-dependent battery control, it is possible to specify, restrict, or prevent the charging/discharging of the battery at/to a defined power.

Battery Management is influenced, for example, by the following settings:

- Permitted battery charging from the public grid
- Power limit of the inverter, energy storage device, or overall system
- Control specifications via Modbus
- Self-consumption optimization

### **IMPORTANT!**

The defined regulations for battery control have the second lowest priority after Self-Consumption Optimization. Depending on the configuration, the regulations may not be fulfilled due to other settings.

The following values can be selected for the Time-dependent battery control regulations:

- **Max. charging power**  
The max. charging power of the battery is the value set in the **Power** input field.  
If no feed into the public grid and/or direct consumption in the home is possible, the set value **Max. charging power** is ignored and the battery is charged with the generated energy.
- **Min. charging power**  
The min. charging power of the battery is the value set in the **Power** input field.
- **Max. discharge power**  
The max. discharge power of the battery is the value set in the **Power** input field.
- **Min. discharge power**  
The min. discharge power of the battery is the value set in the **Power** input field.

The timing of when the regulation applies is set in the **Time** input fields and by selecting the **days of the week**.

It is not possible to define a time window beyond midnight (00:00).

**Example:** Two entries are needed to set a regulation of 22:00 to 06:00: "22:00 - 23:59" and "00:00 - 06:00".

---

### **Service Mode**

If **Service Mode** is activated, the battery system is charged or discharged to the state of charge of 30% and the state of charge of 30% is maintained until the end of the service mode.

### **IMPORTANT!**

The **Service Mode** is only available for Fronius battery systems.

---

### **Examples - Time-dependent battery control**

The following examples serve to explain the energy flows. Efficiency levels are not taken into account.

### Battery system

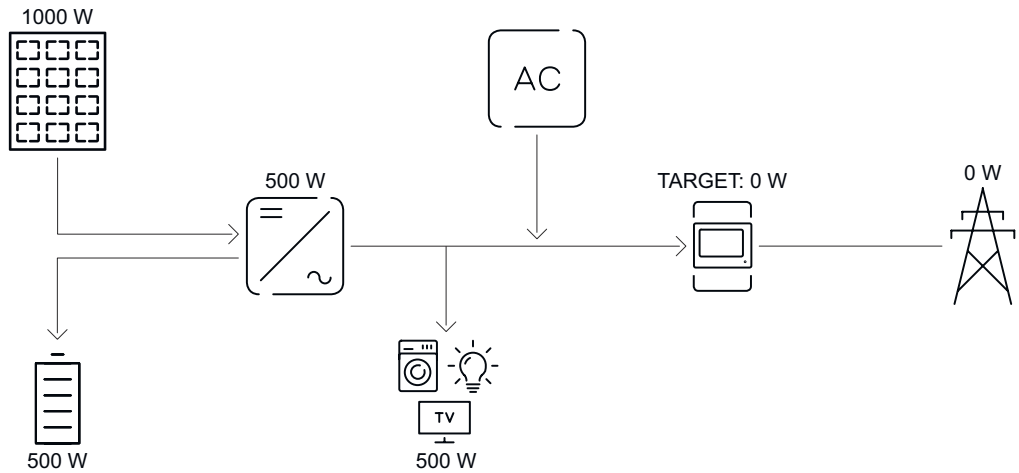

PV system to inverter	1000 W
Power into the battery	500 W
Power output (AC) of the inverter	500 W
Set target value at feed-in point	0 W
Infeed into the public grid	0 W
Consumption in home	500 W

### Battery system without photovoltaics, including second generator in the house

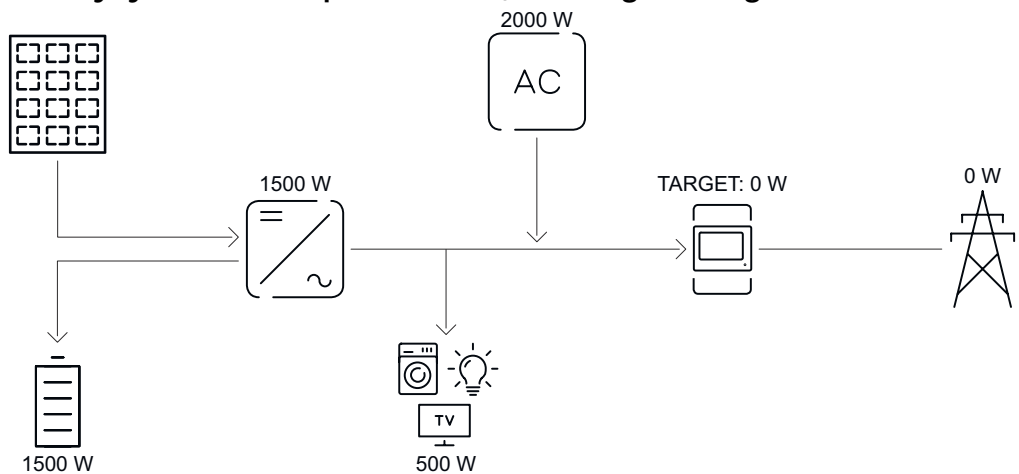

Power into the battery	1500 W
Power consumption (AC) of the inverter	1500 W
Second generator in home network	2000 W
Set target value at feed-in point	0 W
Infeed into the public grid	0 W
Consumption in home	500 W

**Battery system including second generator in the house**

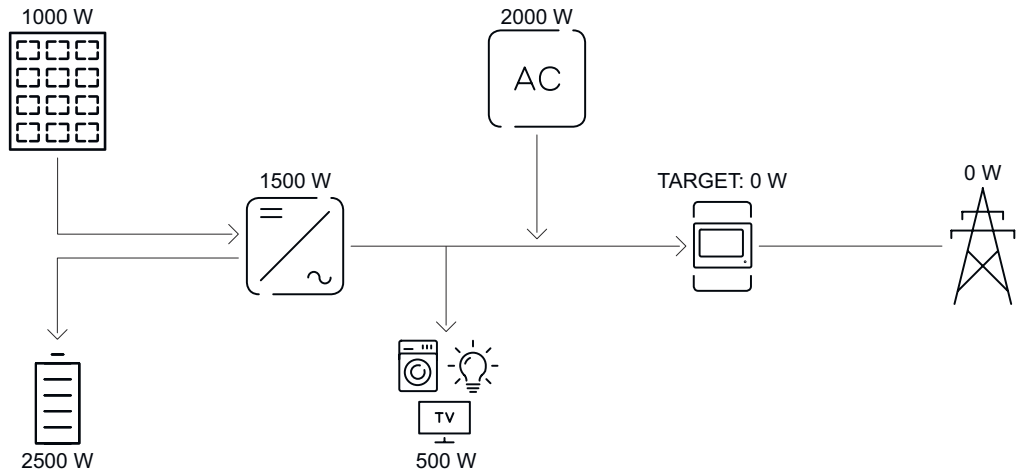

PV system to inverter	1000 W
Power into the battery	2500 W
Power consumption (AC) of the inverter	1500 W
Second generator in home network	2000 W
Set target value at feed-in point	0 W
Infeed into the public grid	0 W
Consumption in home	500 W

**Battery system including second generator in the house  
(with AC max. limitation)**

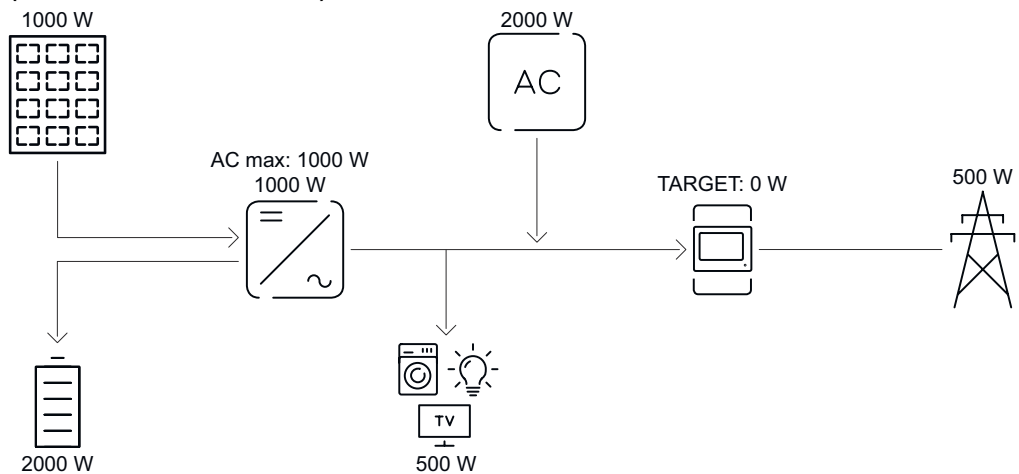

PV system to inverter	1000 W
Power into the battery	2000 W
Power consumption AC max. limited to	1000 W
Power consumption (AC) of the inverter	1000 W
Second generator in home network	2000 W
Set target value at feed-in point	0 W
Infeed into the public grid	500 W
Consumption in home	500 W

## Permitted battery control regulations

A regulation always consists of a restriction or specification, and the **time** and **days of the week** when the regulation is active. The time of regulations with the same restriction (e.g., max. charging power) must not overlap.

### Max. charging and discharging limits

One max. charging and one max. discharging power can be configured at the same time.

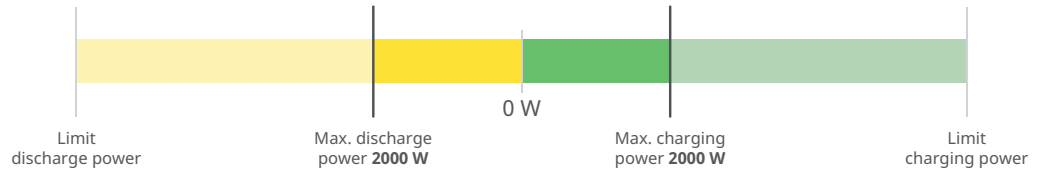

+								
1.	Max. charging power	2000 W	00:00 – 23:59	Mo Tu We Th Fr Sa Su			<input checked="" type="checkbox"/>	▼
2.	Max. discharging power	2000 W	00:00 – 23:59	Mo Tu We Th Fr Sa Su			<input checked="" type="checkbox"/>	▼

### Specify charging range

It is possible to define a charging range using a min. and max. charging limit. In this case, it is not possible to discharge the battery.

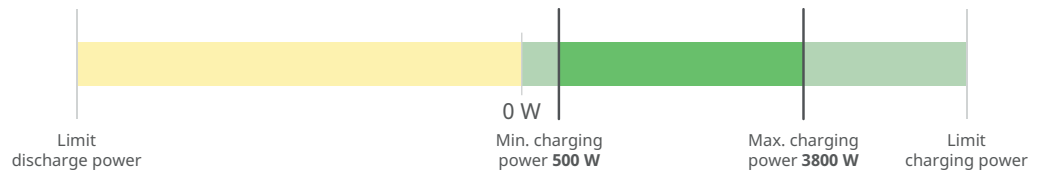

+								
1.	Min. charging power	500 W	03:00 – 04:00	Mo Tu We Th Fr Sa Su			<input checked="" type="checkbox"/>	▼
2.	Max. charging power	3800 W	03:00 – 04:00	Mo Tu We Th Fr Sa Su			<input checked="" type="checkbox"/>	▼

### Specify discharging range

It is possible to define a discharging range using a min. and max. discharging limit. In this case, it is not possible to charge the battery.

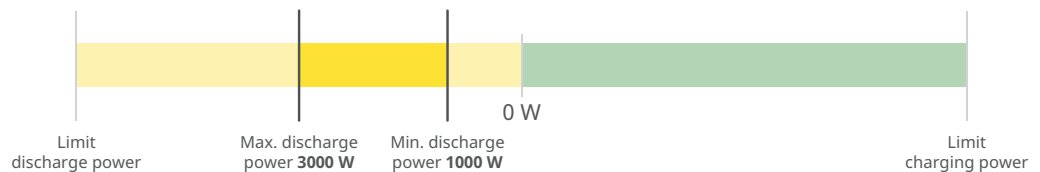

+								
1.	Max. discharging power	3000 W	13:00 – 14:00	Mo Tu We Th Fr Sa Su			<input checked="" type="checkbox"/>	▼
2.	Min. discharging power	1000 W	00:00 – 23:59	Mo Tu We Th Fr Sa Su			<input checked="" type="checkbox"/>	▼

### Specify a defined charge

It is possible to specify a defined charging power by setting the min. and max. charging power to the same value.

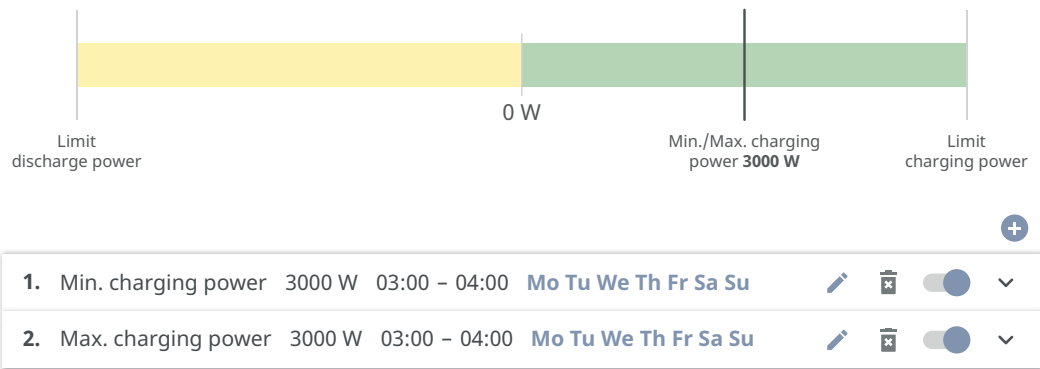

### Specify a defined discharge

It is possible to specify a defined discharging power by setting the min. and max. discharging power to the same value.

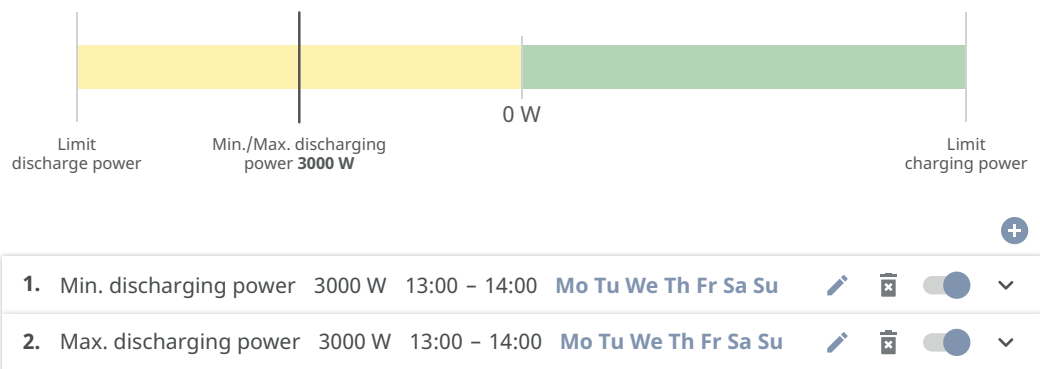

### Possible applications

- Time-dependent energy tariffs
- Battery reservation in the event of market-specific power limitation
- Time-dependent storage reservation for a backup power situation

### PV power reduction

The regulations in the **Battery Management** menu area enable optimal use of the energy generated. Situations may arise, however, in which PV power cannot be used in full due to the time-dependent battery control.

Example	
Fronius inverter (max. output power)	6000 W
Defined discharge of the battery	6000 W
PV power	1000 W

In this case, the inverter would have to reduce the PV power to 0 W, since the output power of the inverter is max. 6000 W and the device is already being fully utilized through discharging.

Since it does not make sense to waste PV power, the power limit is automatically adjusted in battery management such that no PV power is wasted. In the example above, this means that the battery is discharged only at 5000 W, so that the 1000 W PV power can be used.

---

## Load management

### Priorities

If additional components (e.g., battery, Fronius Ohmpilot) are present in the system, the priorities can be set here. Devices having higher priority are actuated first, and subsequently, if there is still excess energy available, the other devices.

### IMPORTANT!

If there is a Fronius Wattpilot in the photovoltaic system, it is considered to be a load. The priority for the load management of the Fronius Wattpilot must be configured in the Fronius Solar.wattpilot app.

### Rules

It is possible for up to four different load management rules to be defined. At the same threshold values, the rules are activated in succession. For deactivation, this is done in reverse; the I/O last switched on is the first to be switched off. In the case of different thresholds, the I/O with the lowest threshold is switched on first, followed by the second lowest, and so on.

I/Os controlled by the produced power are always prioritized over a battery and Fronius Ohmpilot. That is to say that an I/O can switch on and result in the battery no longer being charged or the Fronius Ohmpilot no longer being activated.

### IMPORTANT!

An I/O is activated/deactivated after 60 seconds.

### Load

- Control is **Off** (deactivated).
- Control is effected by the **Power Production**.
- Control is effected by **Power Surplus** (with feed-in limits). This option can only be selected if a meter has been connected. Control is effected using the actual power of feeding in with respect to the grid.

### Thresholds

- **On**: For entering an effective power limit, at which the output is activated.
- **Off**: For entering an effective power limit, at which the output is deactivated.

### Duration

- Field for activating the **Minimum duration per on-signal** for which the output is to be activated for each switch-on process.
- Field for activating the **Maximum duration per day**.
- Field for activating the **Desired duration** for which the output is to be activated in total per day (several switch-on processes are allowed for).

---

## Self-consumption optimization

### Self-Consumption Optimization

Set the operating mode to **Manual** or **Automatic**. The inverter always adjusts to the set **Target value at feed-in point**. In **Automatic** operating mode (factory setting), an adjustment is made to 0 W at the feed-in point (max. self-consumption).

The **Target value at feed-in point** also applies if a further source feeds into this Smart Meter. In this case, however:

- The Fronius Smart Meter must be installed and configured at the feed-in point.
- The **Allow battery charging from other generators in the home network** function must be activated in the **Components > Battery** menu area.

### Target value at feed-in point

If **Manual** has been selected under Self-Consumption Optimization, the **Opera-**

tion Mode (Consumption/Feed-in) and the Target value at feed-in point can be set.

### IMPORTANT!

**Self-Consumption Optimization** has lower priority than **Battery Management**.

---

#### **External generators** (only possible with active battery)

If other decentralized generators are installed in the house, which are incorporated in the self-consumption regulation of the Fronius Hybrid inverter, the **Allow battery charging from other generators in the home network** function must be activated in the **Device Configuration > Components** menu area (see chapter [Components](#) on page 112).

This enables users to charge the battery using energy from the home network via the Fronius inverter (battery support required). You can restrict how much power is consumed by the Fronius inverter by specifying the maximum AC power (AC max.). As a maximum, a power consumption equal to the AC rated power of the Fronius inverter is possible.

---

#### **Battery Management**

Using the **Time-dependent battery control**, it is possible to specify, restrict, or prevent the charging/discharging of the battery at/to a defined power.

**Battery Management** is influenced, for example, by the following settings:

- Permitted battery charging from the public grid
- Power limit of the inverter, energy storage device, or overall system
- Control specifications via Modbus
- Self-consumption optimization

### IMPORTANT!

The defined regulations for **battery control** have the second lowest priority after **Self-Consumption Optimization**. Depending on the configuration, the regulations may not be fulfilled due to other settings.

The following values can be selected for the **Time-dependent battery control** regulations:

- **Max. charging power**  
The max. charging power of the battery is the value set in the **Power** input field.  
If no feed into the public grid and/or direct consumption in the home is possible, the set value **Max. charging power** is ignored and the battery is charged with the generated energy.
- **Min. charging power**  
The min. charging power of the battery is the value set in the **Power** input field.
- **Max. discharge power**  
The max. discharge power of the battery is the value set in the **Power** input field.
- **Min. discharge power**  
The min. discharge power of the battery is the value set in the **Power** input field.

The timing of when the regulation applies is set in the **Time** input fields and by selecting the **days of the week**.

It is not possible to define a time window beyond midnight (00:00).

**Example:** Two entries are needed to set a regulation of 22:00 to 06:00: "22:00 - 23:59" and "00:00 - 06:00".

# System

---

## General

- 1 Enter the name of the system in the input field **PV System Name** (max. 30 characters).
  - 2 Select the **Timezone Region** and **Timezone Location** in the drop-down lists.
  - 3 Click **Save**.
- ✓ *System name, time zone, and time zone location are saved.*
- 

## Update

All available updates for inverters and other Fronius devices are provided on the product pages and in the "Fronius Download Search" area at [www.fronius.com](http://www.fronius.com).

### Update

- 1 Drag the firmware file into the **Drag & drop file here** field, or select via **Browse file**.
- ✓ *Update is started.*
- 

## Setup wizard

The guided setup wizard can be accessed here.

---

## Restoring factory settings

### All settings

Resets all configuration data, apart from the country setup. Changes to the country setup may only be made by authorized personnel.

### All settings without network

Resets all configuration data, apart from the country setup and the network settings. Changes to the country setup may only be made by authorized personnel.

---

## Event log

**Current messages** All current events of the linked system components are displayed here.

### IMPORTANT!

Depending on the type of event, this must be confirmed via the "tick" button so that it can be further processed.

### History

All events of the linked system components that are no longer present are displayed here.

---

## Information

All the information regarding the system and the current settings is displayed and provided for download in this menu area.

---

## License Manager

The power data and functional scope of the inverter are stored in the license file. If the inverter, power stage set PC board, or data communication area is replaced, the license file must also be replaced.

---

## Licensing

### Licensing - online (recommended)

This requires an Internet connection and a completed Fronius Solar.web configuration.

- 1 Finish all installation work (refer to the chapter headed [Closing the inverter's connection area/housing cover, and commissioning](#) on page 103).
- 2 Establish a connection to the user interface of the inverter.
- 3 Enter the serial number and verification code (VCode) of the defective and replacement device. The serial number and VCode can be found on the rating plate of the inverter (refer to the chapter headed [Information on the device](#) on page 59).
- 4 Click the **Start online licensing** button.
- 5 Skip past the Terms and conditions of use and Network settings menu items by clicking **Next**.

✓ *License activation is started.*

### Licensing - offline

There must be no Internet connection in this case. If offline licensing is carried out while there is an active Internet connection, the license file is automatically loaded onto the inverter, resulting in the following error when the license file is uploaded: "The license has already been installed and the wizard can be closed".

- 1 Finish all installation work (refer to the chapter headed [Closing the inverter's connection area/housing cover, and commissioning](#) on page 103).
- 2 Establish a connection to the user interface of the inverter.
- 3 Enter the serial number and verification code (VCode) of the defective and replacement device. The serial number and VCode can be found on the rating plate of the inverter (refer to the chapter headed [Information on the device](#) on page 59).
- 4 Click the **Start offline licensing** button.
- 5 Download the service file onto the mobile device by clicking the **Download service file** button.
- 6 Open [licensemanager.solarweb.com](http://licensemanager.solarweb.com) and log in with username and password.
- 7 Drag the service file into the **Drag service file here or click to upload** field or click to upload it.
- 8 Download the newly generated license file onto the mobile device by clicking the **Download license file** button.
- 9 Switch to the user interface of the inverter and drag the license file into the **Drag & drop license file here** field or select via **Choose license file**.

✓ *License activation is started.*

---

## Support

### Activating the support user

- 1 Click the **Enable Support User Account** button.

✓ *The support user is activated.*

### IMPORTANT!

The support user exclusively enables Fronius Technical Support to configure settings on the inverter via a secure connection. Access is deactivated by clicking the **Terminate Support User Session** button.

---

### Generating support info (for Fronius Support)

- 1 Click the **Generate support info** button.

- 2** The sdp.cry file is downloaded automatically. For manual download, click the **Download support info** button.

✓ *The sdp.cry file is saved in the downloads.*

---

### **Activating remote access**

- 1** Click the **Activate Remote Access** button.

✓ *Remote access is activated for Fronius Support.*

### **IMPORTANT!**

The remote access exclusively enables Fronius Technical Support to access the inverter via a secure connection. In this case, diagnostics data are transmitted, which are used for troubleshooting. The remote access can be activated only upon request by Fronius Support.

# Communication

---

## Network

### Server addresses for data transfer

If a firewall is used for outgoing connections, the below protocols, server addresses, and ports must be allowed for successful data transfer, see:

[https://www.fronius.com/~/downloads/Solar%20Energy/Firmware/SE\\_FW\\_Changelog\\_Firewall\\_Rules\\_EN.pdf](https://www.fronius.com/~/downloads/Solar%20Energy/Firmware/SE_FW_Changelog_Firewall_Rules_EN.pdf)

When using FRITZ!Box products, Internet access must be configured without any restrictions or limitations. The DHCP Lease Time (validity) must not be set to 0 (=infinite).

---

### LAN:



### Establishing a connection:

- 1 Enter the host name.
- 2 Select the connection type: **Automatic** or **Static**.
- 3 For the **Static** connection type, enter the IP address, subnet mask, DNS, and gateway.
- 4 Click the **Connect** button.

✓ *The connection is established.*

After connecting, the status of the connection should be checked.

---

### WiFi:



### Establishing a connection via WPS:

- The access point of the inverter must be active. This is opened by touching the sensor  > Communications LED flashes blue
- 1 Establish the connection to the inverter in the network settings (the inverter is displayed with the name "FRONIUS\_" and the serial number of the device).
  - 2 Enter the password from the rating plate and confirm.  
**IMPORTANT!**  
To enter the password in Windows 10, first select the **Connect using a security key instead** link to be able to establish the connection with the password.
  - 3 Enter the IP address 192.168.250.181 in the address bar of the browser and confirm.
  - 4 In the **Communication > Network > WLAN > WPS** menu area, click the **Activate** button.
  - 5 Activate WPS on the WiFi router (see WiFi router documentation).
  - 6 Click on the **Start** button. The connection is established automatically.
  - 7 Log in to the user interface of the inverter.
  - 8 Check the network details and connection to Fronius Solar.web.

After connecting, the status of the connection should be checked.

**Selecting and connecting to a WiFi network:**The networks found are displayed in the list. Clicking on the Refresh button will ↻ perform a new search for available WiFi networks. The selection list can be limited further via the **Search network** input field.

- 1 Select network from the list.
  - 2 Select the connection type: **Automatic** or **Static**.
  - 3 For the **Automatic** connection type, enter the WiFi password and host name.
  - 4 For the **Static** connection type, enter the IP address, subnet mask, DNS, and gateway.
  - 5 Click the **Connect** button.
- ✓ *The connection is established.*

After connecting, the status of the connection should be checked.

---

#### Access point:



The inverter serves as the access point. A PC or mobile device connects directly to the inverter. Connecting to the Internet is not possible. Assign a **Network Name (SSID)** and **Network Key (PSK)** to establish a connection. Assign a **Network Key (PSK)** with at least 20 characters, consisting of upper and lower case letters, special characters, and numbers, to protect the device from unauthorized access.

It is possible to operate a connection via WiFi and via the access point at the same time.

---

## Modbus

The inverter communicates with system components (e.g., Fronius Smart Meter) and other inverters via Modbus. The primary device (Modbus Client) sends control commands to the secondary device (Modbus Server). The control commands are executed by the secondary device.

### RTU Server

The following input fields and functions are available for communication via Modbus RTU:

---

#### Meter address offset

The value entered (1-247) is the identification number (unit ID) assigned to the meter.

Factory setting: 200

---

#### Inverter address

The value entered (1-247) is the identification number (unit ID) assigned to the inverter.

Factory setting: 1

---

#### SunSpec Model Type

There are two different settings, depending on the SunSpec model.

**float:** SunSpec Inverter Model 111, 112, 113 or 211, 212, 213.

**int + SF:** SunSpec Inverter Model 101, 102, 103 or 201, 202, 203.

---

---

**Interface**

Select one of the two interfaces **Modbus 0 (M0) RTU** or **Modbus 1 (M1) RTU**.

---

**Baud Rate**

The baud rate influences the speed of the transmission between the individual components connected in the system. When selecting the baud rate, it should be ensured that this is the same on the transmit and receive side.

---

**Parity**

The parity bit can be used for parity checks. This is used to identify transmission errors. In this case, a parity bit can ensure a specified number of bits. The value (0 or 1) of the parity bit must be calculated at the transmitter, and is checked at the receiver using the same calculation. The calculation of the parity bit can be carried out for even or odd parity.

---

**Allow Control**

If this option is activated, the inverter is controlled via Modbus.

Inverter control includes the following functions:

- On/off
  - Power reduction
  - Setting a constant power factor (cos phi)
  - Setting a constant reactive power
  - Battery control settings with battery
- 

**TCP Server**

The following input fields and functions are available for communication via Modbus TCP:

---

**Meter address offset**

The value entered (1-247) is the identification number (unit ID) assigned to the meter.

Factory setting: 200

---

**SunSpec Model Type**

There are two different settings, depending on the SunSpec model.

**float:** SunSpec Inverter Model 111, 112, 113 or 211, 212, 213.

**int + SF:** SunSpec Inverter Model 101, 102, 103 or 201, 202, 203.

---

**Modbus port**

Number of the TCP port (502 or 1502) to be used for Modbus communication.

---

**Meter Address**

The value entered is the identification number (unit ID) assigned to the meter, which can be found on the user interface of the inverter in the **Communication > Modbus** menu area.

Factory setting: 200

---

**Allow Control**

If this option is activated, the inverter is controlled via Modbus.

Inverter control includes the following functions:

- On/off
  - Power reduction
  - Setting a constant power factor (cos phi)
  - Setting a constant reactive power
  - Battery control settings with battery
-

---

**Restrict Control**

Restrict the control of the inverter to a device with a fixed IP address.

---

**Cloud control**

The utility/energy supplier can influence the output power of the inverter with **Cloud control**. This requires the inverter to have an active Internet connection.

Parameter	Display	Description
<b>Cloud control</b>	Off	Cloud control of the inverter is deactivated.
	On	Cloud control of the inverter is activated.

Profile	Value range	Description
<b>Allow cloud control for regulatory purposes (Technician)</b>	Deactivated/ Activated	The function may be mandatory for proper operation of the system.*
<b>Allow cloud control for Virtual Power Plants (Customer)</b>	Deactivated/ Activated	If the <b>Allow remote control for regulatory purposes (technician)</b> function is activated (technician access required), the <b>Allow remote control for virtual power plants</b> function is automatically activated and cannot be deactivated.*

**\* Cloud control**

A virtual power plant is an interconnection of multiple generators. This virtual power plant can be controlled by means of the cloud control via the Internet. An active inverter Internet connection is a prerequisite for this. System data are transferred.

---

**Solar API**

The **Solar API** is an IP-based, open JSON interface. If enabled, IOT devices in the local network may access inverter information without authentication. For security reasons, the interface is disabled in the factory. Activate the interface manually if it is required for a third-party application (e.g., EV charger, smart home solutions, etc.). If there is a Fronius Wattpilot in the network, the inverter automatically activates the **Solar API**.

Fronius recommends using Fronius Solar.web for monitoring and analyzing the inverter and connected system components.

In the event of a firmware update to version 1.14.x, the Solar API setting is applied. In systems with a version below 1.14.x, the Solar API is activated; with higher versions, it is deactivated but can be switched on and off via the menu.

**Manually activating the Fronius Solar API**

On the user interface of the inverter in the **Communication > Solar API** menu area, activate the function **Activate communication via Solar API**.

---

**Fronius Solar.web**

In this menu, you can agree to the technically necessary data processing or reject it.

In addition, the transfer of analysis data and remote configuration via Fronius Solar.web can be enabled or disabled.

# Safety and grid requirements

---

## Country setup

### **WARNING!**

#### **Danger from unauthorized fault analyses and repair work.**

This can result in serious injury and damage to property.

- ▶ Fault analyses and repair work on the PV system may only be carried out by installers/service technicians from authorized specialist companies in accordance with national standards and regulations.

### **NOTE!**

#### **Risk due to unauthorized access.**

Incorrectly set parameters can have a negative effect on the public grid and/or the grid power feed operation of the inverter and result in the loss of standard conformity.

- ▶ Parameters may only be adjusted by installers/service technicians from authorized specialist companies.
- ▶ Do not give the access code to third parties and/or unauthorized persons.

### **NOTE!**

#### **Risk due to incorrectly set parameters.**

Incorrectly set parameters can have a negative effect on the public grid and/or cause inverter malfunctions and failures and result in the loss of standard conformity.

- ▶ Parameters may only be adjusted by installers/service technicians from authorized specialist companies.
- ▶ Parameters may only be adjusted if this has been approved or requested by the utility.
- ▶ Any parameter adjustments must be made in compliance with nationally applicable standards and/or directives as well as the specifications of the utility.

The **Country Setup** menu area is intended exclusively for installers/service technicians from authorized specialist companies. To apply for the access code required for this menu area, see chapter [Requesting inverter codes in Solar.SOS](#).

The selected country setup for the country in question contains preset parameters in accordance with nationally applicable standards and requirements. Changes may need to be made to the selected country setup depending on local grid conditions and the specifications of the utility.

---

## Requesting inverter codes in Solar.SOS

The **Country Setup** menu area is intended exclusively for installers/service technicians from authorized specialist companies. The inverter access code required for this menu area can be requested in the Fronius Solar.SOS portal.

Requesting inverter codes in Fronius Solar.SOS:

- 1 Open [solar-sos.fronius.com](https://solar-sos.fronius.com) in the browser
- 2 Log in with your Fronius account
- 3 At the top right, click on the drop-down menu 

- 4 Select the **Show inverter codes** menu item
  - ✓ A contract page appears on which the request for the access code to change the grid parameters for Fronius inverters is located
- 5 Accept the terms and conditions of use by checking **Yes, I have read and agree to the terms of use** and click **Confirm & Save**
- 6 After that, the codes can be retrieved in the drop-down menu at the top right under **Show inverter codes**



### CAUTION!

#### Risk due to unauthorized access.

Incorrectly set parameters can have a negative effect on the public grid and/or the grid power feed operation of the inverter and result in the loss of standard conformity.

- ▶ Parameters may only be adjusted by installers/service technicians from authorized specialist companies.
- ▶ Do not give the access code to third parties and/or unauthorized persons.

### Absolute Generation Limit

Activating this function limits the output power of the inverter to the specified value in watts.

### Import limitation

Energy companies or grid operators can prescribe import limitations for inverters. The amperage is limited to the set value.

- 1 Under **Limit** select **Current Limitation**.
- 2 Enter the **limit value** in amperes.
- 3 Click on **Save**.

### Export limitation

Energy companies or grid operators can prescribe feed-in limits for inverters (e.g., max. 70% of the kWp or max. 5 kW). The effective power at the grid connection point (installation location of the Fronius Smart Meter or primary meter) is limited to the set value.

The feed-in limit takes account of self-consumption in the household before the power of an inverter is reduced. An individual limit can be set.

In order to minimize the yield losses due to the power of feeding in limitation, the power available from the module array can be:

- Used for (controllable) loads such as Fronius Ohmpilot, Fronius Wattpilot, I/O-controlled loads
- Stored in a battery

If these possibilities have been exhausted, the power drawn from the module array is reduced to such an extent that the feed-in limit is not exceeded.

Installation variants with an inverter, Fronius Smart Meter, and system components are listed under [Different operating modes](#).

#### Total DC power of the system

Input field for the total DC power of the entire system in Wp.

This value is used if the **Maximum grid feed-in power** is specified in %.

**Power Control** deactivated

The inverter converts all available PV energy.

**Power Control** activated

Feeding in limited with the following selection options:

- **Total Power Limit**

The entire photovoltaic system is limited to a fixed feed-in limit. A value must be set for the permissible total power of feeding in.

**IMPORTANT!**

**Power Control** settings are automatically applied for the dynamic feed-in limit of I/O power management. **Total Power Limit** is the default configuration.

**Export Limit Control (Soft Limit)**

If this value is exceeded, the inverter readjusts down to the set value within the time required by the national standards and regulations.

**Maximum grid feed-in power**

Input field for the **Maximum grid feed-in power** in W or % (setting range: -10 to 100%).

If there is no meter in the system or if the primary meter has failed, the inverter limits its output power to the set value.

**Export Limit Protection (Hard Limit)**

**IMPORTANT!**

This function is only available if **Export Limit Control (Soft Limit)** is activated.

If this value is exceeded, the inverter switches off within max. 5 seconds. This value must be higher than the value set for **Export Limit Control (Soft Limit)**.

Activate the function **Reduce inverter power to 0% if meter connection has been lost** for control in the event of a fail-safe.

The use of WiFi for communication between the Smart Meter and the inverter is not recommended for the fail-safe function. Even short-term disconnections can cause the inverter to shut down. This problem is particularly common with weak WiFi signal strengths, a slow or overloaded WiFi connection, and automatic channel selection of the router.

**Limit multiple inverters (only Soft Limit)**

Control of the dynamic feed-in limit for several inverters, for details on configuration, see chapter [Dynamic feed-in limit with multiple inverters](#) on page 138.

<b>Example: Feed-in limit (not taking into account the efficiency)</b>	
PV system to Fronius inverter:	5,000 W
Consumption in home:	1,000 W
Maximum permitted power of feeding in of the entire system:	60% = 3,000 W
<b>Situation 1: The battery may be charged</b>	
Power at the grid feed-in point:	0 W
Power at the inverter output:	1,000 W

<b>Example: Feed-in limit (not taking into account the efficiency)</b>	
Power into the battery:	3,000 W
<b>Situation 2: The battery must not be charged</b>	
Power at the grid feed-in point	3,000 W
Power at the inverter output:	4,000 W
Power into the battery:	0 W
In this example, only 3,000 W may be fed into the grid at the grid feed-in point. However, loads that are located between the inverter and grid feed-in point can be supplied by means of additional feed-in of the inverter and are adjusted.	

### Dynamic feed-in limit with multiple inverters

#### **IMPORTANT!**

To view and change settings in this menu item, select the user **Technician**, and enter and confirm the password for the user **Technician**. Settings in this menu area may only be made by trained and qualified personnel.

The inverter can be used as a primary device to control dynamic feed-in limits for additional Fronius inverters (secondary devices) so that feed-in limits prescribed by energy companies or utilities can be centrally managed. This control refers to the **Soft Limit** feed-in limit (see [Export limitation](#)). The following requirements must be met:

- Power Control and the **Limit multiple inverters (only Soft Limit and I/O Power Management)** function are activated and configured on the user interface of the primary device.
- Primary device and secondary device(s) are physically connected to the same network router via LAN.
- Inverter Control via Modbus TCP is activated and configured for all secondary devices.
- The Fronius Smart Meter is configured as a primary meter and connected to the primary device.

#### **IMPORTANT!**

Only one primary meter is required for the primary device.

#### **IMPORTANT!**

If an inverter with a battery is connected, it must be used as the primary device for dynamic feed-in limits.

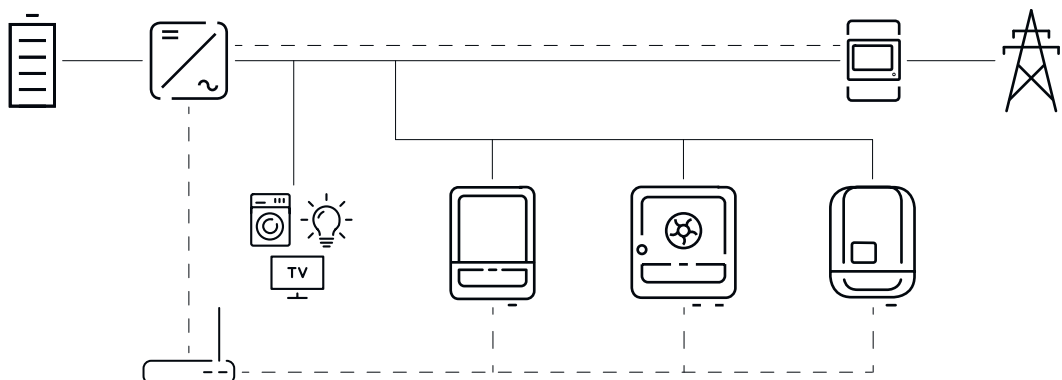

Example connection diagram for dynamic feed-in limit with multiple inverters

### System limits

- Systems with a maximum of 20 inverters (1 primary device + 19 secondary devices) are supported.
- The control is designed for photovoltaic systems with a total output of up to 300 kW.
- In the case of larger system capacities, the control times in the system are extended.
- For systems >300 kW, the use of a plant controller is recommended.

The dynamic feed-in limit is available for the following device combinations:

Primary device	Secondary devices
Fronius GEN24	Fronius GEN24, Fronius Verto, Fronius Tauro, Fronius Argeno, Fronius SnapINverter with Fronius Datamanager 2.0*
Fronius Verto	Fronius GEN24, Fronius Verto, Fronius Tauro, Fronius Argeno, Fronius SnapINverter with Fronius Datamanager 2.0*
Fronius Tauro	Fronius GEN24, Fronius Verto, Fronius Tauro, Fronius Argeno, Fronius SnapINverter with Fronius Datamanager 2.0*

\* Up to four additional Fronius SnapINverters can be connected to each Fronius SnapINverter with Fronius Datamanager 2.0.

### Primary meter





The Fronius Smart Meter acts as the only primary meter and is connected directly to the primary device. The Smart Meter measures the total output power of all inverters into the grid and passes this information to the primary device.

### Primary device

The export limitation is configured on the user interface of the inverter:

- 1 In the **Safety and Grid Regulations > Export Limitation** menu area, activate the **Power Control** function and select **Total Power Limit**.
- 2 Configure the country-specific settings.
- 3 In the **Safety and Grid Regulations > Export Limitation** menu area, activate the **Limit multiple inverters (only Soft Limit and I/O Power Limit)** function.

The primary device automatically scans the network for available secondary devices. A list of the inverters found is displayed. Click the refresh button  to perform the search again.

DETECTED INVERTERS		ADDITIONAL INVERTERS				
26 Inverters were found 						<a href="#">Use all Inverters</a>
Status	Name	Device Type	Serial Number	Hostname	Ip Address	Use Inverter
INACTIVE	jf-rop	S10RW	33302856	jf-rop.local	10.5.48.141	
INACTIVE	Symo-Gen24-12SC7	S12RW	34590379	Symo-Gen24-12-SC7.j...	10.5.48.29	
INACTIVE	pilot2v-haas1	V30RW	45454545	pilot2v-haas1.local	10.5.48.165	

- 4 Activate **Use Inverter** against all secondary devices to which an export limitation applies. Click **Use all inverters** to enable the function for the primary device and all secondary devices.

The status of the inverters listed is displayed as follows:

- **Inactive:** Secondary device is not configured for the power control.
- **Disconnected:** Secondary device is configured, network connection not possible.
- **Connected:** Secondary device is configured and accessible via the network of the primary device.

- 5 In the **Safety and Grid Regulations > I/O Power Management** menu area, set the controlling priorities as follows:
  1. **I/O Power Limit**
  2. **Export Limitation**
  3. **Modbus**

### Adding Fronius Argeno and other inverters manually

- 1 Select the **Additional inverters** menu area.
- 2 Enter the name, hostname or IP address, and the Modbus address of the secondary device.
- 3 Click **Add inverter +**.

### Secondary device

A secondary device takes over the export limitation of the primary device. No data are sent to the primary device for the export limitation. The following configurations must be set for the power control:

### User interface secondary device GEN24 / Verto / Tauro

- 1 Select the user **Technician** and enter the password for the user **Technician**.
- 2 In the **Modbus** menu area, activate the **TCP Server** mode and the **Allow Control** function.
- 3 For a fail-safe scenario, in the **Safety and Grid Regulations > I/O Power Management** menu area, set the controlling priorities as follows:
  1. **Modbus**
  2. **Export Limitation**
  3. **I/O Power Limit**
- 4 In the **Safety and Grid Regulations > Export Limitation** menu area, select and edit the following settings:
  - Activate the **Power Control** function
  - Select **Total Power Limit** and specify the total DC power of the entire system in W
  - Enable **Export Limit Control (Soft Limit)** and enter a value of 0 W for the **Maximum grid feed-in power**.
  - Enable the **Reduce inverter power to 0% if meter connection has been lost** function

---

## I/O Power Management

### General

Settings relevant to the grid operator are defined as rules under this menu item. This relates to an effective power limit in % or watts and/or a power factor specification.

### IMPORTANT!

To view and change settings in this menu item, select the user **Technician**, and enter and confirm the password for the user **Technician**. Only technical specialists may make settings in this menu area.

Under **Rules**, expand a menu area (e.g., **Rule 1**). Configure the following settings:

### Limitation

#### IMPORTANT!

A dynamic feed-in limit for several inverters can be configured under [Export limitation](#). I/O power management rules are transferred from the inverter (primary device) to connected inverters in the system (secondary devices).

Select the following rules for power management:

- **I/O Generation Limit (%)**: The total output power of the connected inverter is statically limited to the defined value of the absolute rated power.
- **Export Limit Control (W)**: The effective power fed in at the grid connection point is limited to the set value (e.g., 5000 watts). The output powers of the inverters (primary and secondary devices) are dynamically adjusted depending on their self-consumption.
- **Shutdown single device**: The inverter stops grid power feed operation and switches to standby mode.

#### IMPORTANT!

The rules for shutdown apply to this device and cannot be applied to other inverters in the system.

#### Input pattern (assignment of individual I/Os)

- 1 click = white, contact open
- 2 clicks = blue, contact closed
- 3 clicks = gray, not used

#### Power Factor ( $\cos \varphi$ ) (define value)

#### Impedance response

- **Capacitive**
- **Inductive**

#### DNO Feedback

If the rule is activated, always configure the **DNO Feedback** output, e.g., for operating a signal device.

The **Import** and **Export** of defined rules can be carried out in the data format \*.fpc.

If there is an active rule for the control of the inverter, the device indicates this in the **overview** of the user interface under **Device State**.

---

#### Controlling Priorities

Used to set controlling priorities for I/O Power Management (DRM or ripple control receiver), the feed-in limit, and control via Modbus.

1 = highest priority, 3 = lowest priority

Local priorities of the I/O Power Management, the feed-in limit, and the Modbus interface are deactivated by cloud control commands (regulatory purposes and virtual power plants) – see [Cloud control](#) on page 133 – and by backup power.

In terms of control priorities, the device differentiates between **power control** and **inverter shutdown**. Inverter shutdown always takes precedence over power control. An inverter shutdown command is always executed and does not need to be prioritized.

### Power control

- I/O Power Management (DRM/ripple control receiver signal)—according to command
- Export Limitation (Soft Limit)—always active
- Modbus (generation limit)—according to command

### Inverter shutdown

- Shutdown single device
- Export Limitation (Hard Limit)
- Modbus (shutdown command) – according to command

### Connection diagram - 4 relays

Connect the ripple control signal receiver and the I/O terminals of the inverter to one another as shown in the connection diagram. For distances greater than 10 m between the inverter and the ripple control signal receiver, use a shielded data communication cable (CAT 5 or higher) with twisted cable pairs. Connect the shielding on one side to the push-in terminal of the data communication area (SHIELD).

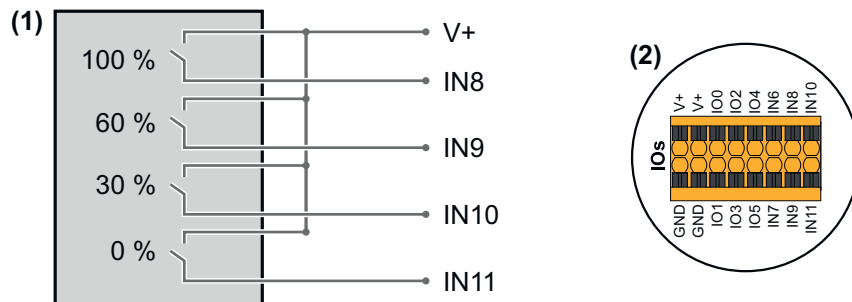

- (1) Ripple control signal receiver with 4 relays for effective power limitation.
- (2) I/O connection terminals of the data communication area.

### Use pre-configured file for 4-relay operation:

- 1 Download the file (.fpc) under [4-relay operation](#) to the mobile device.
  - 2 Upload the file (.fpc) in the **I/O Power Management** menu area by clicking the **Import** button.
  - 3 Click **Save**.
- ✓ *The settings for 4-relay operation are saved.*

## I/O power management settings - 4 relays

### I/O Power Management



DNO feedback pin  
Not used

Rules + Add

**Rule 1** 🗑️ 🟢 ^

0 2 4 6 8 10  
1 3 5 7 9 11

Limitation  
I/O Generation Limit (%)

Active Power \* %  
 100

Power Factor (cos φ) \* Impedance response  
 1 Capacitive

DNO Feedback

**Rule 2** 🗑️ 🟢 ^

0 2 4 6 8 10  
1 3 5 7 9 11

Limitation  
I/O Generation Limit (%)

Active Power \* %  
 60

Power Factor (cos φ) \* Impedance response  
 1 Capacitive

DNO Feedback

**Rule 3** 🗑️ 🟢 ^

0 2 4 6 8 10  
1 3 5 7 9 11

Limitation  
I/O Generation Limit (%)

Active Power \* %  
 30

Power Factor (cos φ) \* Impedance response  
 1 Capacitive

DNO Feedback

**Rule 4** 🗑️ 🟢 ^

0 2 4 6 8 10  
1 3 5 7 9 11

Limitation  
I/O Generation Limit (%)

Active Power \* %  
 0

Power Factor (cos φ) \* Impedance response  
 1 Capacitive

DNO Feedback

📄 Import 📄 Export

- 0 Activate Backup interlock
- 1 Rule 1
- 2 None
- 3 None
- 4 None
- 5 None
- 6 Open grid relais feedback
- 7 Backup interlock feedback
- 8 I/O control
- 9 I/O control
- 10 I/O control
- 11 I/O control

## Connection diagram - 3 relays

Connect the ripple control signal receiver and the I/O terminals of the inverter to one another as shown in the connection diagram. For distances greater than 10 m between the inverter and the ripple control signal receiver, use a shielded data communication cable (CAT 5 or higher) with twisted cable pairs. Connect the shielding on one side to the push-in terminal of the data communication area (SHIELD).

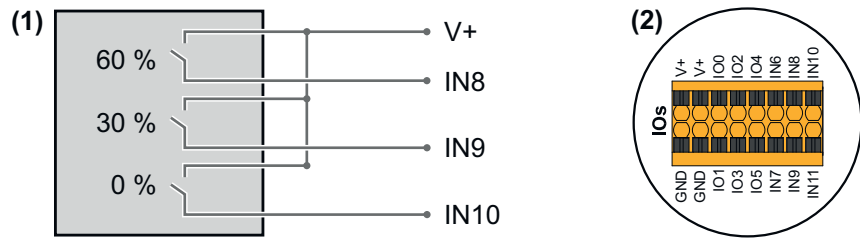

- (1) Ripple control signal receiver with 3 relays for effective power limitation.
- (2) I/O connection terminals of the data communication area.

**Use pre-configured file for 3-relay operation:**

- 1 Download the file (.fpc) under [3-relay operation](#) to the mobile device.
- 2 Upload the file (.fpc) in the **I/O Power Management** menu area by clicking the **Import** button.
- 3 Click **Save**.

✓ *The settings for 3-relay operation are saved.*

## I/O power management settings - 3 relays

### I/O Power Management

DNO feedback pin  
Not used

Rules + Add

**Rule 1**

0 2 4 6 8 10  
1 3 5 7 9 11

Limitation  
I/O Generation Limit (%)

Active Power \* 100 %

Power Factor (cos φ) \* 1 Impedance response Capacitive

DNO Feedback

**Rule 2**

0 2 4 6 8 10  
1 3 5 7 9 11

Limitation  
I/O Generation Limit (%)

Active Power \* 60 %

Power Factor (cos φ) \* 1 Impedance response Capacitive

DNO Feedback

**Rule 3**

0 2 4 6 8 10  
1 3 5 7 9 11

Limitation  
I/O Generation Limit (%)

Active Power \* 30 %

Power Factor (cos φ) \* 1 Impedance response Capacitive

DNO Feedback

**Rule 4**

0 2 4 6 8 10  
1 3 5 7 9 11

Limitation  
I/O Generation Limit (%)

Active Power \* 0 %

Power Factor (cos φ) \* 1 Impedance response Capacitive

DNO Feedback

Import Export

- 0 Activate Backup interlock
- 1 Rule 1
- 2 None
- 3 None
- 4 None
- 5 None
- 6 Open grid relais feedback
- 7 Backup interlock feedback
- 8 I/O control
- 9 I/O control
- 10 I/O control
- 11 None

## Connection diagram - 2 relays

Connect the ripple control signal receiver and the I/O terminals of the inverter to one another as shown in the connection diagram. For distances greater than 10 m between the inverter and the ripple control sig-

nal receiver, use a shielded data communication cable (CAT 5 or higher) with twisted cable pairs. Connect the shielding on one side to the push-in terminal of the data communication area (SHIELD).

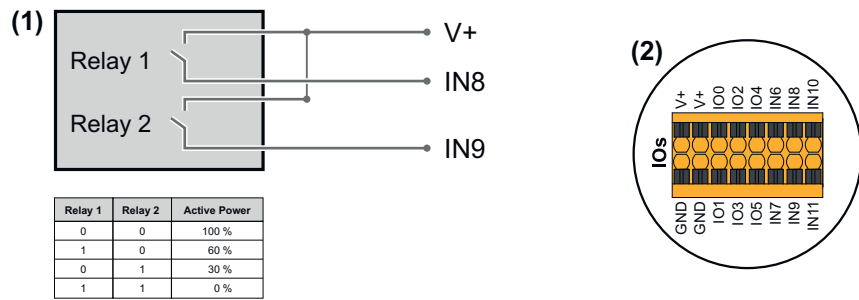

- (1) Ripple control signal receiver with 2 relays for effective power limitation.
- (2) I/O connection terminals of the data communication area.

**Use pre-configured file for 2-relay operation:**

- 1** Download the file (.fpc) under [2-relay operation](#) to the mobile device.
  - 2** Upload the file (.fpc) in the **I/O Power Management** menu area by clicking the **Import** button.
  - 3** Click **Save**.
- ✓ *The settings for 2-relay operation are saved.*

## I/O power management settings - 2 relays

### I/O Power Management



DNO feedback pin  
Not used

Rules + Add

**Rule 1**

Limitation  
I/O Generation Limit (%)

Active Power \* 100 %

Power Factor (cos φ) \* 1 Impedance response Capacitive

DNO Feedback

**Rule 2**

Limitation  
I/O Generation Limit (%)

Active Power \* 60 %

Power Factor (cos φ) \* 1 Impedance response Capacitive

DNO Feedback

**Rule 3**

Limitation  
I/O Generation Limit (%)

Active Power \* 30 %

Power Factor (cos φ) \* 1 Impedance response Capacitive

DNO Feedback

**Rule 4**

Limitation  
I/O Generation Limit (%)

Active Power \* 0 %

Power Factor (cos φ) \* 1 Impedance response Capacitive

DNO Feedback

Import Export

- 0 Activate Backup interlock
- 1 Rule 1
- 2 None
- 3 None
- 4 None
- 5 None
- 6 Open grid relais feedback
- 7 Backup interlock feedback
- 8 I/O control
- 9 I/O control
- 10 None
- 11 None

## Connection diagram - 1 relay

The ripple control signal receivers and the I/O terminals of the inverter can be connected to one another as shown in the connection diagram. For distances of over 10 m between the inverter and the ripple control signal receiver, a CAT 5 STP cable is recommended as a minimum and the shielding must be connected on one side at the push-in terminal of the data communication area (SHIELD).



- (1) Ripple control signal receiver with 1 relay for effective power limitation.
- (2) I/O connection terminals of the data communication area.

**Use pre-configured file for 1-relay operation:**

- 1** Download the file (.fpc) under [1-relay operation](#) to the mobile device.
  - 2** Upload the file (.fpc) in the **I/O Power Management** menu area by clicking the **Import** button.
  - 3** Click **Save**.
- ✓ *The settings for 1-relay operation are saved.*

## I/O power management settings - 1 relay

## I/O Power Management

V+/GND

I/O

I

V+	V+	0	2	4	6	8	10
GND	GND	1	3	5	7	9	11

DNO feedback pin  
Not used ▼

**Rules**
+ Add

**Rule 1**
🗑️  ^

0	2	4	6	8	10
1	3	5	7	9	11

Limitation  
I/O Generation Limit (%) ▼

Active Power \*

100 %

Power Factor (cos φ) \*

Impedance response

1
Capacitive ▼

DNO Feedback

**Rule 2**
🗑️  ^

0	2	4	6	8	10
1	3	5	7	9	11

Limitation  
I/O Generation Limit (%) ▼

Active Power \*

0 %

Power Factor (cos φ) \*

Impedance response

1
Capacitive ▼

DNO Feedback

📄 Import
📄 Export

- 0 Activate Backup interlock
- 1 Rule 1
- 2 None
- 3 None
- 4 None
- 5 None
- 6 Open grid relais feedback
- 7 Backup interlock feedback
- 8 I/O control
- 9 None
- 10 None
- 11 None

## Connecting the ripple control receiver with several inverters

The grid operator may request the connection of one or more inverters to a ripple control receiver in order to limit the effective power and/or the power factor of the photovoltaic system.

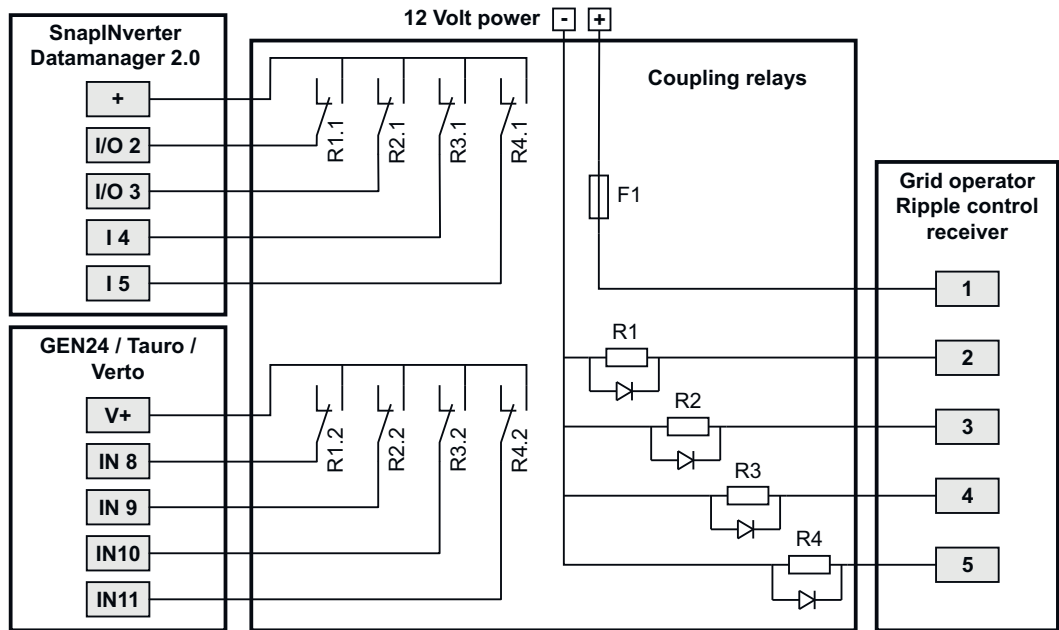

Connection diagram for ripple control receiver with several inverters

The following Fronius inverters can be connected to the ripple control receiver via a distributor (coupling relay):

- Symo GEN24
- Primo GEN24
- Tauro
- Verto
- SnapINverter (only devices with Fronius Datamanager 2.0)

**IMPORTANT!**

On the user interface of each inverter connected to the ripple control receiver, the **4-relay mode** setting (see [Connection diagram - 4 relays](#) and [I/O power management settings - 4 relays](#)) must be activated.

**Autotest  
(CEI 0-21)**

**Description**

The **Autotest** makes it possible to check the Italian protection function, required by the applicable standard for monitoring the voltage and frequency limit values of the inverter during commissioning. In normal operation, the inverter constantly checks the real-time actual value of the voltage and frequency of the grid.

Once the Autotest has started, different individual tests are carried out automatically, in succession. Depending on the grid conditions, the duration of the test is approximately 15 minutes.

**IMPORTANT!**

In Italy, the inverter may only be commissioned following a successfully completed Autotest (CEI 0-21). If an Autotest is not passed, grid power feed operation may not take place. Once the Autotest is started, it must be completed successfully. The Autotest cannot be started during backup power mode.

Umax	Test for checking the maximum voltage in the phase conductors
Umin	Test for checking the minimum voltage in the phase conductors
fmax	Test for checking the maximum mains frequency
fmin	Test for checking the minimum mains frequency

fmax alt	Test for checking an alternative maximum mains frequency
fmin alt	Test for checking an alternative minimum mains frequency
U outer min	Test for checking the minimum outer voltages
U longT.	Test for checking the 10 min. voltage average

### Print to PDF

- 1 Click the **Print to PDF** button.
- 2 Enter the file name into the input field and click on the **Print** button.

✓ *The PDF is created and shown.*

### Note on the Autotest

The limit values are set in the **Safety and Grid Regulations > Country Setup > Grid Support Functions** menu area.

The **Country Setup** menu area is intended exclusively for installers/service technicians from authorized specialist companies. The inverter access code required for this menu area can be requested in the Fronius Solar.SOS portal (see chapter [Requesting inverter codes in Solar.SOS](#) on page 135).



# Options



# Surge protection device (SPD)

---

## General

A surge protection device (SPD) protects against temporary overvoltages and diverts surge currents (e.g., lightning strike). Based on an overall lightning protection concept, the SPD contributes to the protection of the photovoltaic system components.

For detailed information on the wiring diagram of the surge protection device, see chapter [Surge protection device \(SPD\)](#) on page 230.

If the surge protection device is triggered, the color of the indicator changes from green to red (mechanical display) and the operating status LED of the inverter lights up red (see chapter [Button functions and LED status indicator](#) on page 37). The error code **1030 WSD Open** is displayed on the user interface of the inverter in the **System > Event Log** menu area or in the user menu under **Notifications** and in Fronius Solar.web. In this case, the inverter must be repaired by an authorized specialist company.

### IMPORTANT!

The inverter also switches off if the 2-pin signal cable of the surge protection device is interrupted or damaged.

### External surge protection device

To receive a notification when external surge protection devices are triggered, it is recommended to connect the feedback contacts connected in series to the WSD input.

---

## Safety

### WARNING!

#### **Danger due to electrical voltage on live parts of the photovoltaic system.**

This can result in serious injury and damage to property.

- ▶ Disconnect live parts of the photovoltaic system on all pins and on all sides.
- ▶ Secure against re-activation in accordance with national regulations.
- ▶ Allow the capacitors of the inverter to discharge (2 minutes).
- ▶ Check that the inverter is de-energized with a suitable measuring device.

### WARNING!

#### **Danger due to work that has been carried out incorrectly.**

This can result in serious injury and damage to property.

- ▶ Installing and connecting an option must only be carried out by service personnel trained by Fronius and only within the scope of the respective technical regulations.
- ▶ Follow the safety rules.

---

## Scope of supply

The surge protection device (SPD) is available as an option and can be retrofitted to the inverter.

For technical data, see chapter [Technical data](#) on page 193.

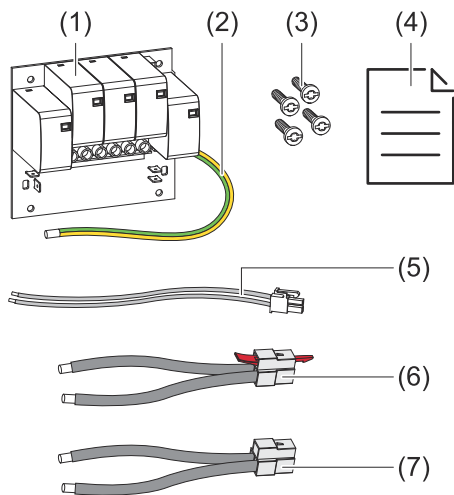

1. PC board
2. 4 TX20 screws
3. Ground conductor
4. 2-pin signal cable
5. PV- cable
6. PV+ cable
7. User information

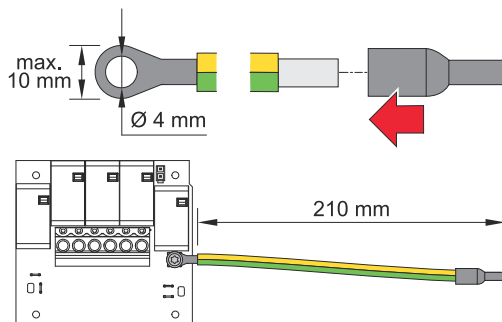

**IMPORTANT!**

A larger ground conductor cross-section may be required depending on national standards and regulations.

Fit a ring cable lug (internal diameter: 4 mm, outer diameter: max. 10 mm) as well as a corresponding ferrule. Fasten the ground conductor to the PC board with a torque of 1.5 Nm.

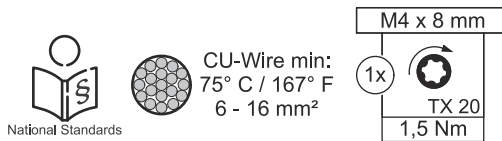

**De-energizing the inverter**

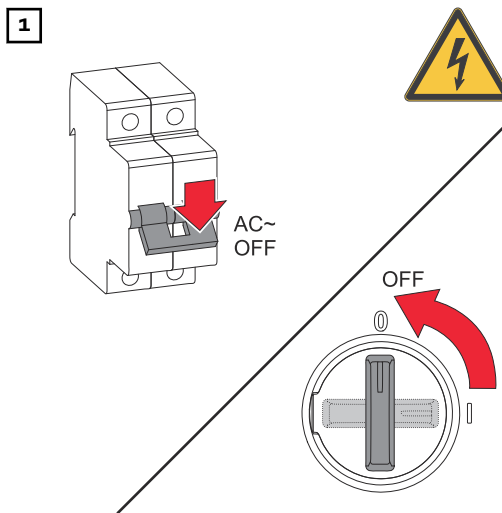

Turn off the automatic circuit breaker. Set the DC disconnect to the "off" switch position.

**2** Disconnect connections from the solar module strings (+/-).

3

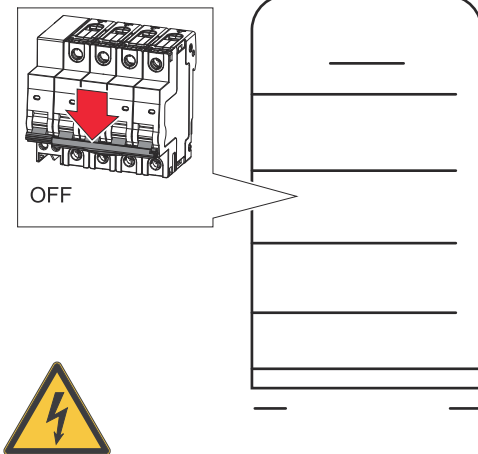

Disconnect connections from the solar module strings (+/-). Switch off the battery connected to the inverter.

Wait for the capacitors of the inverter to discharge (2 minutes).

## Installation

### CAUTION!

#### **Danger due to insufficiently dimensioned ground conductors.**

This may result in damage to the inverter due to thermal overload.

- The national standards and regulations must be observed for dimensioning of the ground conductor.

1

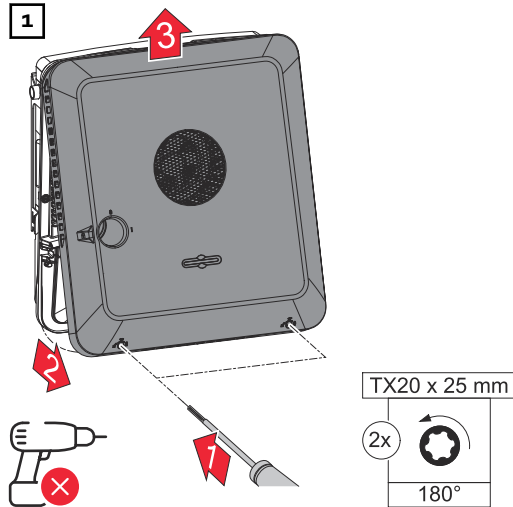

Loosen the 2 screws on the underside of the housing cover by rotating them 180° to the left using a screwdriver (TX20). Then lift the housing cover away from the inverter at the bottom and detach from above.

2

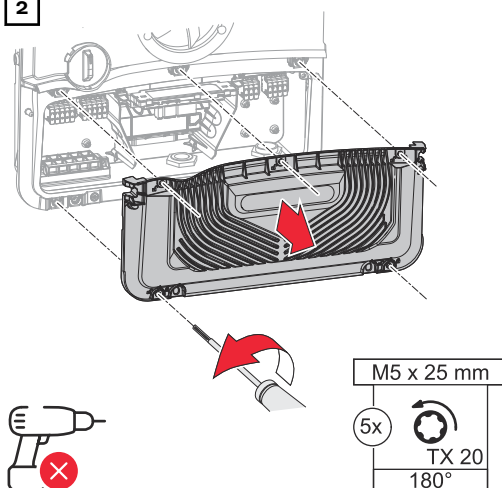

Loosen the 5 screws on the connection area cover by rotating them 180° to the left using a screwdriver (TX20). Remove the connection area cover from the device.

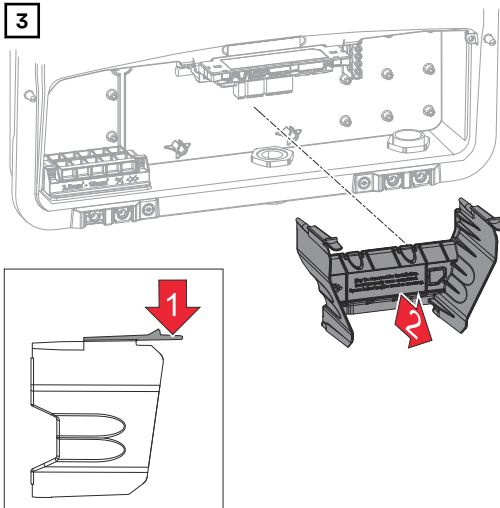

Remove the connection area divider by pressing the snap tabs.

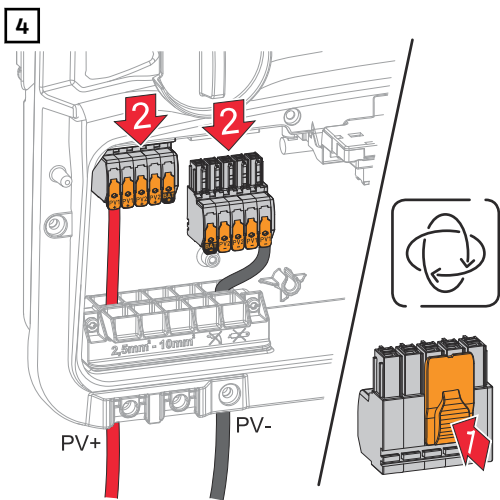

Remove the DC push-in terminals from the slots.

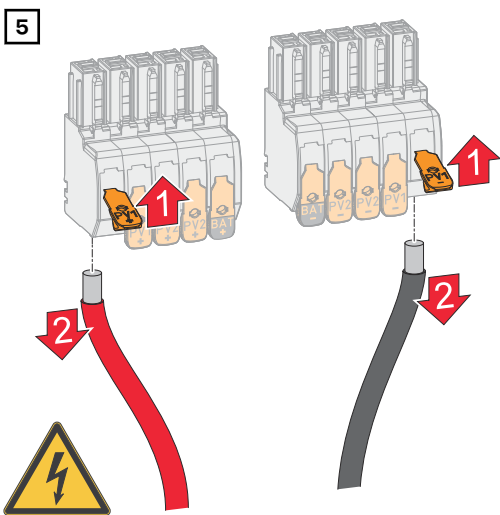

Remove cables from the terminals (only necessary for an existing installation).

6

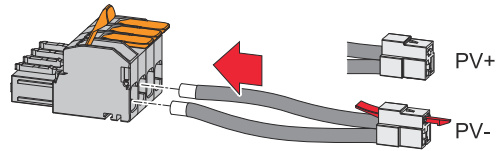

Connect the PV+/PV- cables supplied to the corresponding connection sockets.

**IMPORTANT!**

When connecting, note the labeling on the cables.

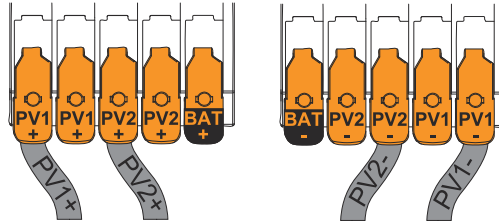

7

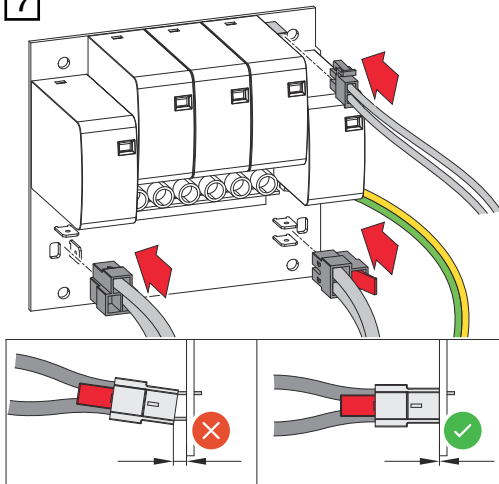

Connect the cables supplied to the corresponding connection sockets on the PC board.

**IMPORTANT!**

The plugs must be plugged in to the stops on the PC board.

8

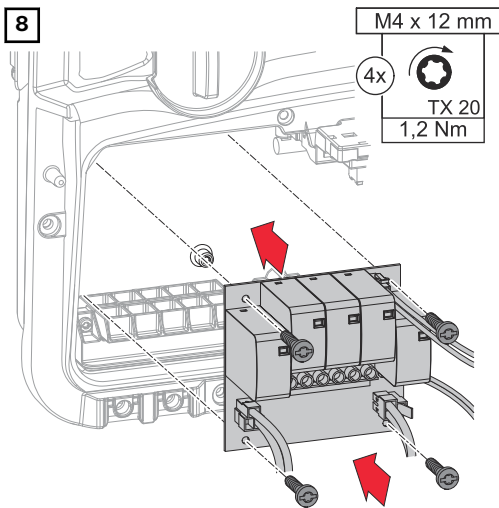

Insert the PC board into the inverter and fasten it using the 4 screws supplied (TX20) and a torque of 1.0 - 1.2 Nm.

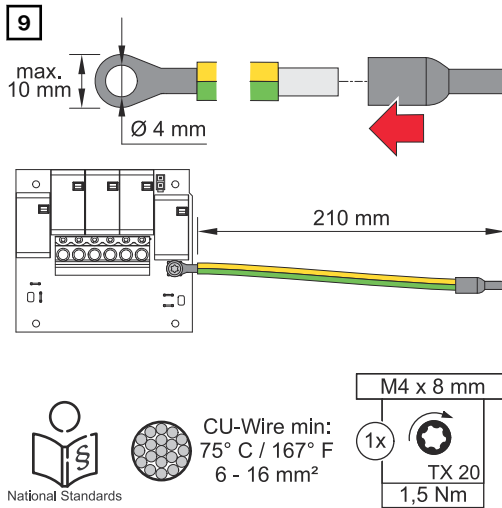

**IMPORTANT!**

A larger ground conductor cross-section may be required depending on national standards and regulations.

Dimension the cable cross-section of the ground conductor in accordance with national standards and regulations and attach a ring cable lug (internal diameter: 4 mm, outer diameter: max. 10 mm) as well as a corresponding ferrule. Fasten the ground conductor to the PC board with a torque of 1.5 Nm.

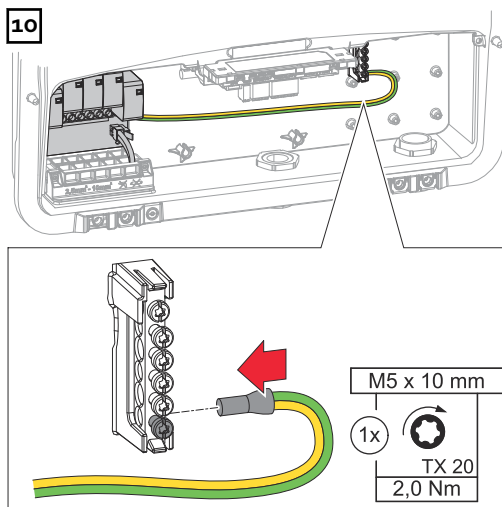

Fasten the ground conductor to the first input from the bottom on the ground electrode terminal using a screwdriver (TX20) and a torque of 1.8-2 Nm.

**IMPORTANT!**

Using other inputs can make the use of the connection area dividers more difficult or damage the ground conductor.

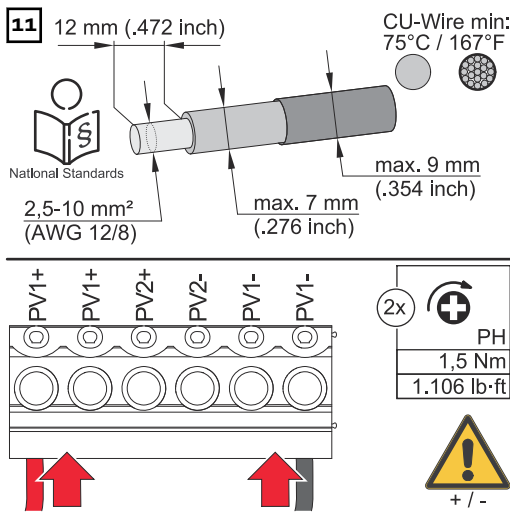

Strip the insulation of the single conductors by 12 mm and fasten to the respective slot of the terminal located on the PC board with a torque of 1.2-1.5 Nm.

**IMPORTANT!**

The cable cross-section must be selected according to the specifications for the respective power category of the inverter (see chapter [Permissible cables for the electrical connection](#) on page 68).

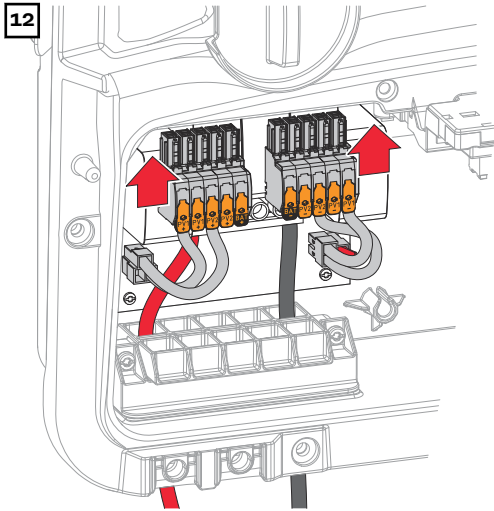

Push the DC push-in terminals into the corresponding slot until there is an audible click.

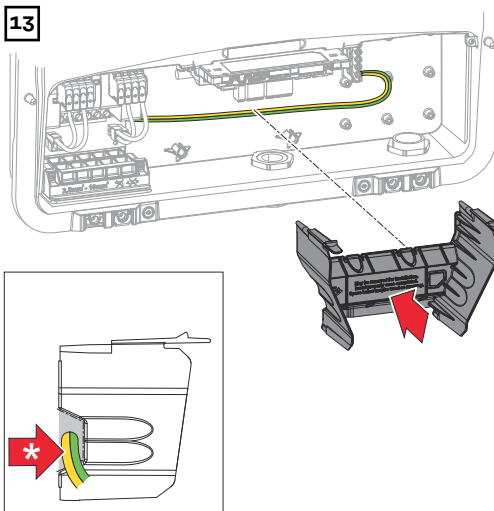

Re-insert the connection area divider.

\* Lay the ground conductor in the integrated cable duct.

**IMPORTANT!**

Ensure that the ground conductor is not damaged (e.g., broken, kinked, crushed, etc.) when inserting the connection area divider.

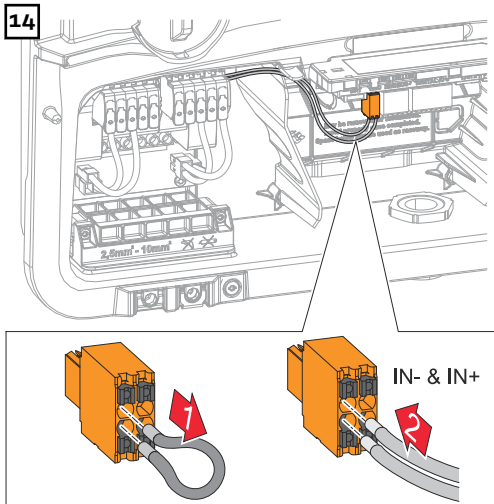

Remove the bypass installed ex works on the push-in WSD terminal.

Connect the signal cables to the IN- and IN+ slots in accordance with the labeling on the push-in WSD terminal.

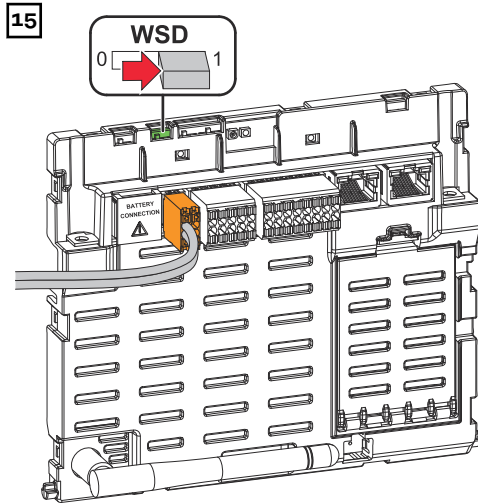

Check whether the WSD switch is in position 1; adjust if necessary (factory setting: position 1).

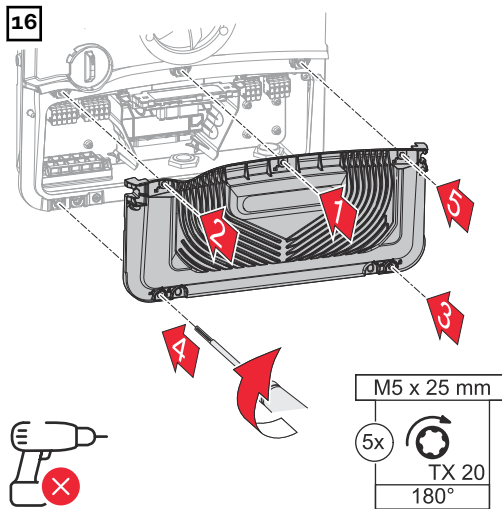

Place the cover on the connection area. Tighten the 5 screws by rotating them 180° to the right in the indicated order using a screwdriver (TX20).

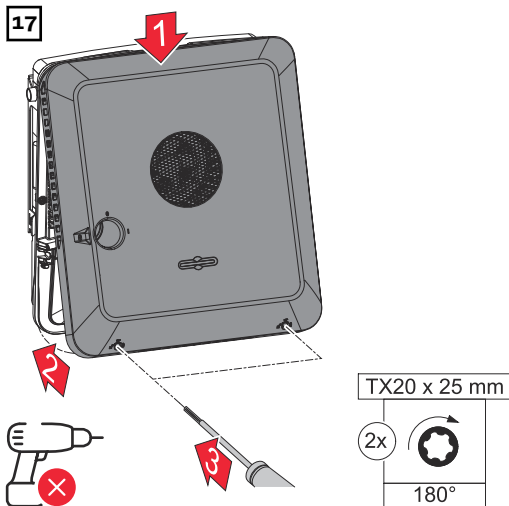

Clip the housing cover into the inverter from above. Press on the lower part of the housing cover and tighten the 2 screws by rotating them 180° to the right using a screwdriver (TX20).

**Starting up the inverter**

**1**

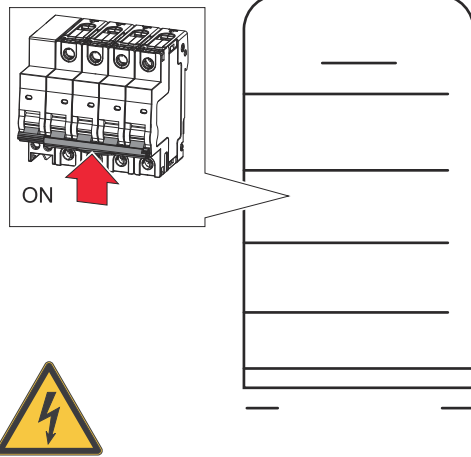

Connect the solar module strings (+/-). Switch on the battery connected to the inverter.

**2**

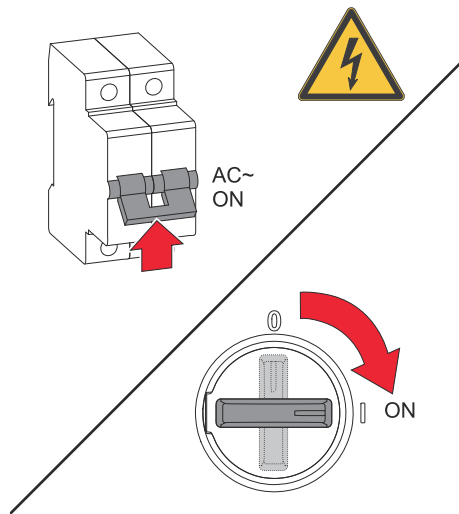

Set the DC disconnect to the "on" switch position. Turn on the automatic circuit breaker.

# DC Connector Kit GEN24

## General

The DC Connector Kit GEN24 (item number: 4,240,046) enables PV-connection strings with a total current of more than 22 A to be connected.

## General information about PV modules

To enable suitable PV modules to be chosen and to use the inverter as efficiently as possible, it is important to bear the following points in mind:

- If insolation is constant and the temperature is falling, the open-circuit voltage of the PV modules will increase. The open-circuit voltage must not exceed the max. permissible system voltage. An open-circuit voltage above the indicated values will damage the inverter, and all warranty rights will become null and void.
- The temperature coefficients on the data sheet of the PV modules must be observed.
- Exact values for sizing the PV modules can be obtained using suitable calculation tools, such as the [Fronius Solar.creator](#).

### IMPORTANT!

Before connecting up the PV modules, check that the voltage for the PV modules specified by the manufacturer corresponds to the actual measured voltage.

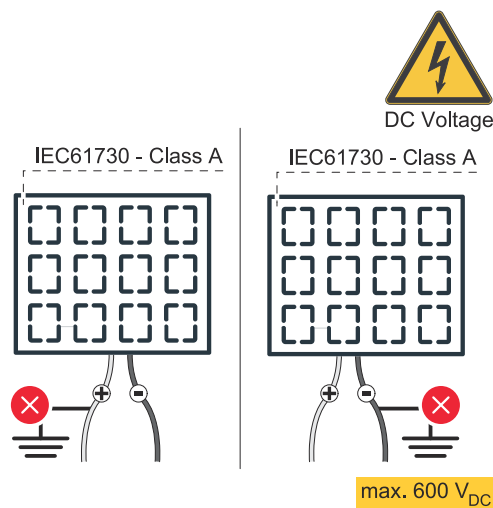

### IMPORTANT!

The PV modules connected to the inverter must comply with the IEC 61730 Class A standard.

### IMPORTANT!

Solar module strings must not be grounded.

## Safety



### WARNING!

#### **Danger from incorrect operation and work that is not carried out properly.**

This can result in severe personal injury and damage to property.

- ▶ The commissioning, maintenance, and service work in the inverter's power stage set may only be carried out by Fronius-trained service personnel in accordance with the technical specifications.
- ▶ Read the installation instructions and operating instructions before installing and commissioning the equipment.

**⚠ WARNING!**

**Danger from mains voltage and DC voltage from PV modules that are exposed to light.**

This can result in severe personal injury and damage to property.

- ▶ All connection, maintenance, and service work should only be carried out when the AC and DC sides have been disconnected from the inverter and are de-energized.
- ▶ Only an authorized electrical engineer is permitted to connect this equipment to the public grid.

**⚠ WARNING!**

**Danger of an electric shock due to improperly connected terminals/PV plug connectors.**

An electric shock can be fatal.

- ▶ When connecting, ensure that each pole of a string is routed via the same PV input, e.g.:  
**+ pole string 1** to the input **PV 1.1+** and **- pole string 1** to the input **PV 1.1-**

**⚠ WARNING!**

**Danger from damaged and/or contaminated terminals.**

This can result in severe personal injury and damage to property.

- ▶ Prior to connection work, check the terminals for damage and contamination.
- ▶ Remove any contamination while the equipment is de-energized.
- ▶ Have defective terminals replaced by an authorized specialist company.

**Scope of supply**

The DC Connector Kit GEN24 is available as an option and can be retrofitted to the inverter.

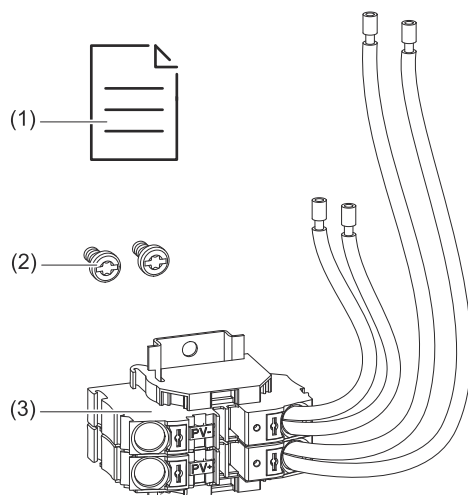

1. User information
2. 2 TX20 screws
3. DC Connector Kit GEN24

## De-energizing the inverter

1

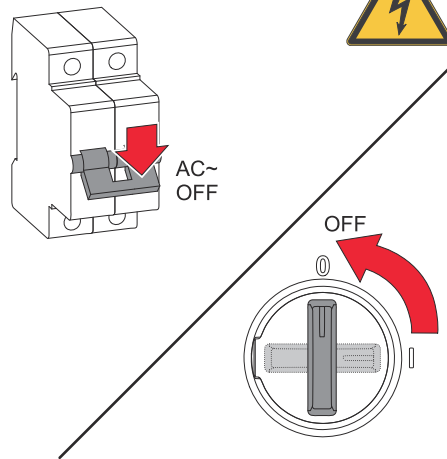

Turn off the automatic circuit breaker. Set the DC disconnect to the "off" switch position.

2

Disconnect connections from the solar module strings (+/-).

3

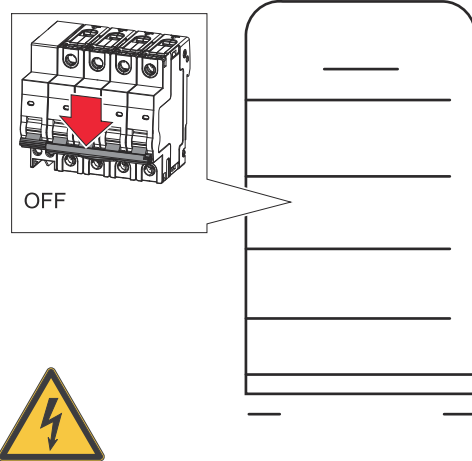

Disconnect connections from the solar module strings (+/-). Switch off the battery connected to the inverter.

Wait for the capacitors of the inverter to discharge (2 minutes).

## Installation

### CAUTION!

#### **Risk due to insufficiently dimensioned DC cables.**

This may result in damage to the inverter due to thermal overload.

- For dimensioning the DC cables, observe the information according to chapter [Permissible cables for the electrical connection](#) on page 68.

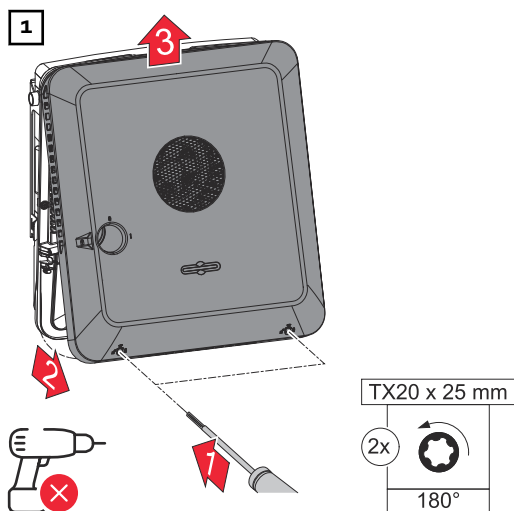

Loosen the 2 screws on the underside of the housing cover by rotating them 180° to the left using a screwdriver (TX20). Then lift the housing cover away from the inverter at the bottom and detach from above.

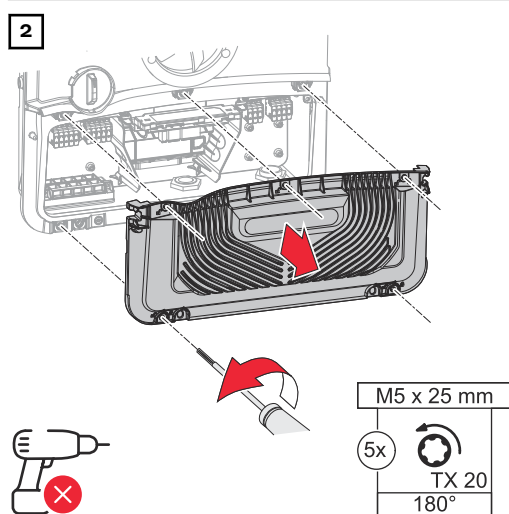

Loosen the 5 screws on the connection area cover by rotating them 180° to the left using a screwdriver (TX20). Remove the connection area cover from the device.

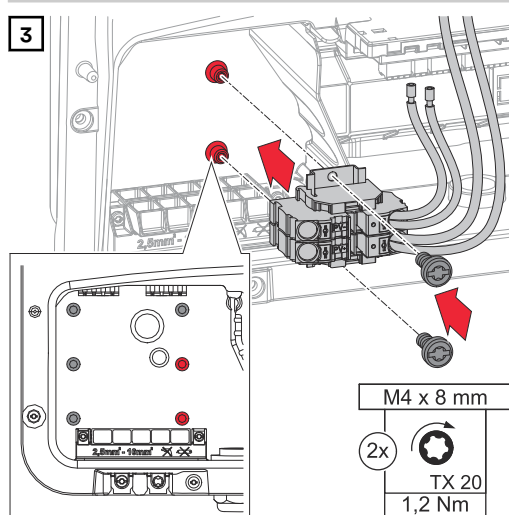

Insert the DC Connector GEN24 into the inverter and fasten it using the 2 screws supplied (TX20) and a torque of 1.2 Nm.

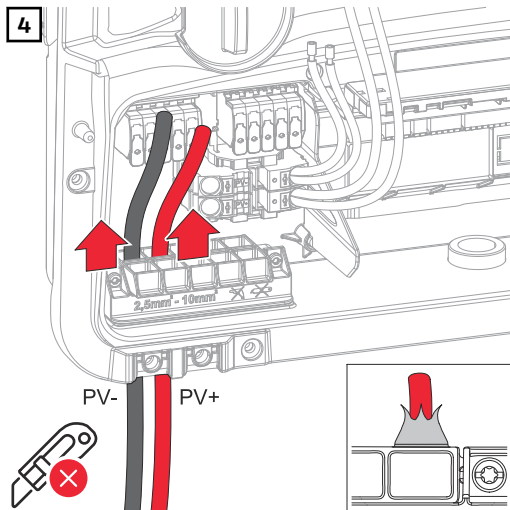

Push the DC cables through the DC bushings by hand.

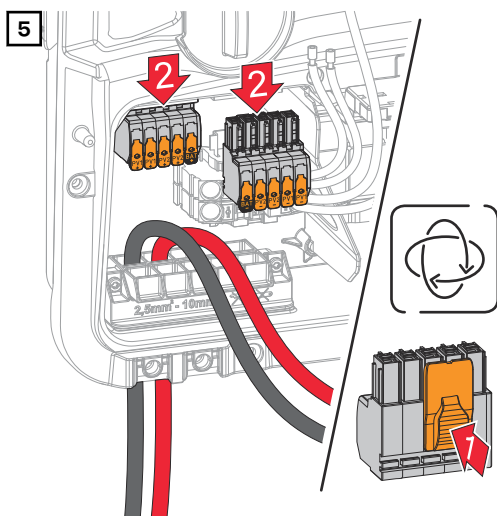

Press the latch on the back of the terminal and remove the DC terminals.

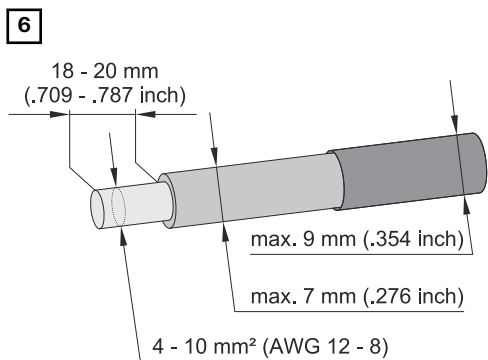

Strip the insulation of the single conductors by 18 - 20 mm. Select the cable cross-section in accordance with the instructions in [Permissible cables for the electrical connection](#) from page 68.

CU-Wire min:  
75° C / 167° F

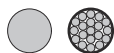

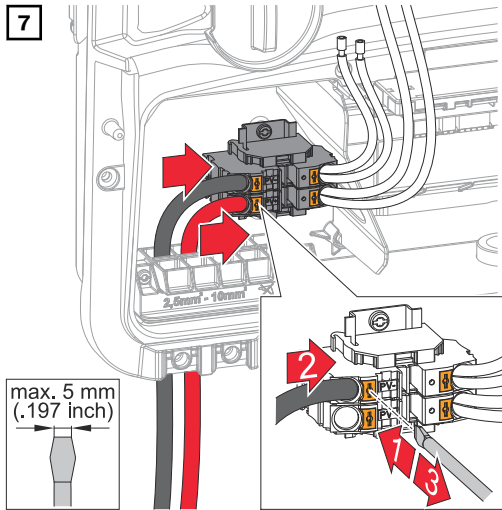

Press the latch on the terminal with a slotted screwdriver. Insert the stripped single conductor into the slot provided in the terminal as far as it will go. Then remove the slotted screwdriver from the latch.

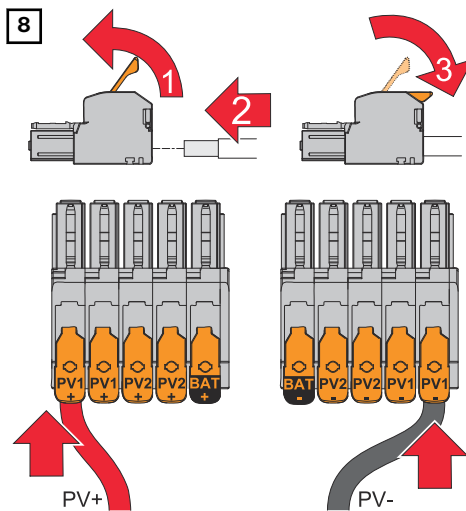

Lift the operating lever of the terminal to open. Insert the stripped single conductor into the slot provided in the terminal as far as it will go. Then close the operating lever until it engages.

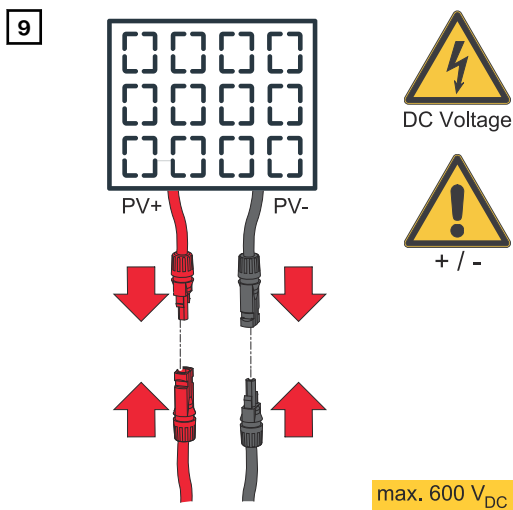

Connect the solar module strings (+/-).

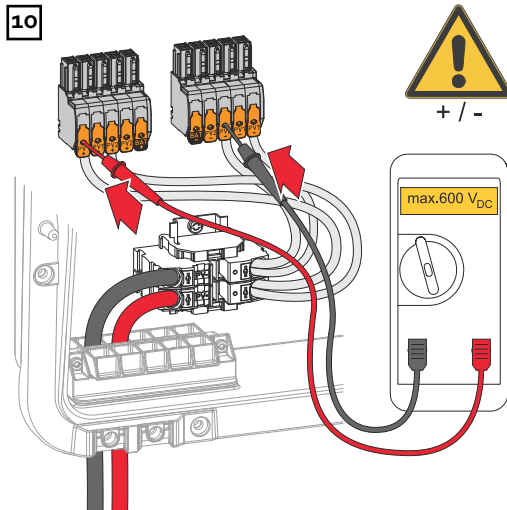

Use a suitable measuring instrument to check the voltage and polarity of the DC cabling.

**CAUTION!**

**Danger due to polarity reversal at the terminals.**

This may result in severe damage to the inverter.

- ▶ Use a suitable measuring instrument to check the voltage (**max. 600 V<sub>DC</sub>**) and the polarity of the DC cabling.

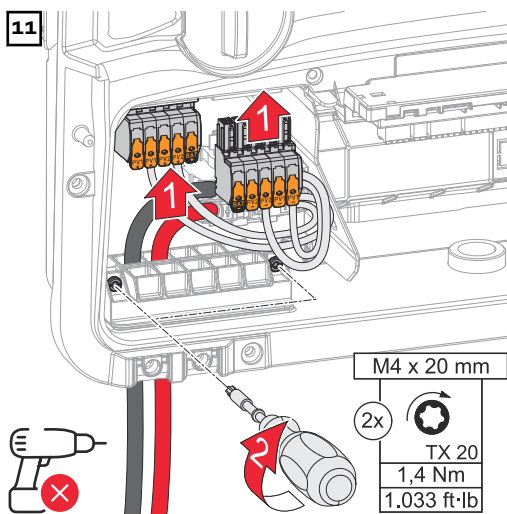

Insert the DC terminals into the respective slot until they engage. Fasten the screws of the strain-relief device to the housing using a screwdriver (TX20) and a torque of 1.3 - 1.5 Nm.

**NOTE!**

**Risk due to overtorque at the strain-relief device.**

Damage to the strain-relief device may result.

- ▶ Do not use a drill driver.

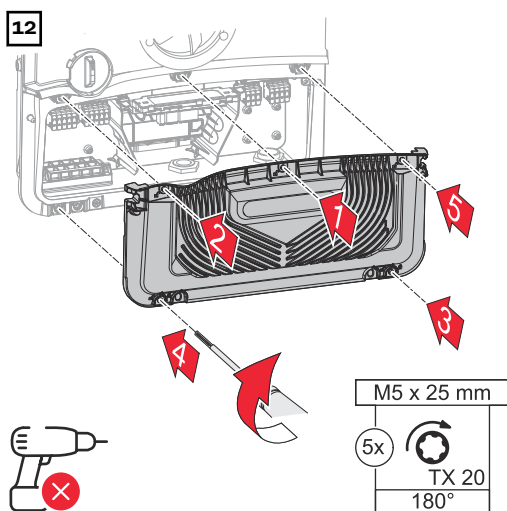

Place the cover on the connection area. Tighten the 5 screws by rotating them 180° to the right in the indicated order using a screwdriver (TX20).

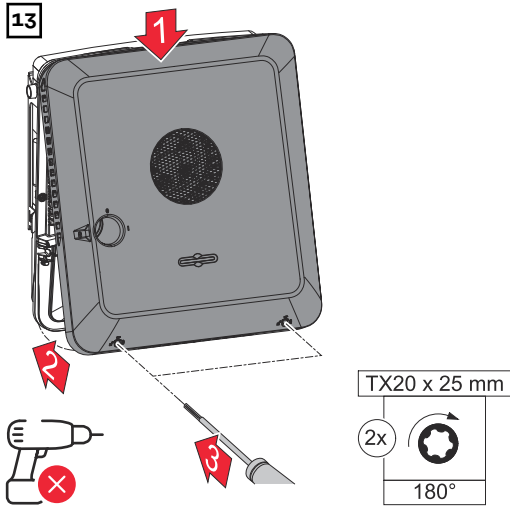

Clip the housing cover into the inverter from above.  
Press on the lower part of the housing cover and tighten the 2 screws by rotating them 180° to the right using a screwdriver (TX20).

### Starting up the inverter

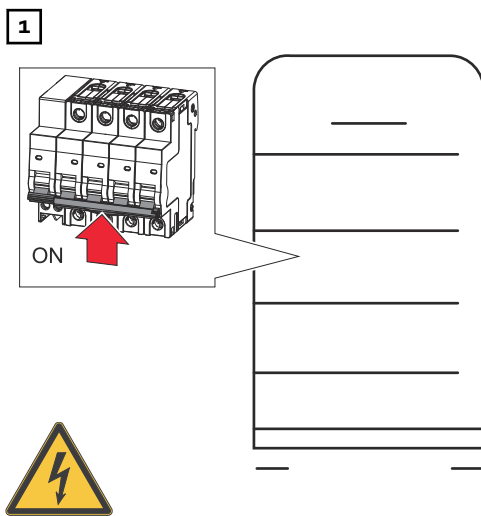

Connect the solar module strings (+/-).  
Switch on the battery connected to the inverter.

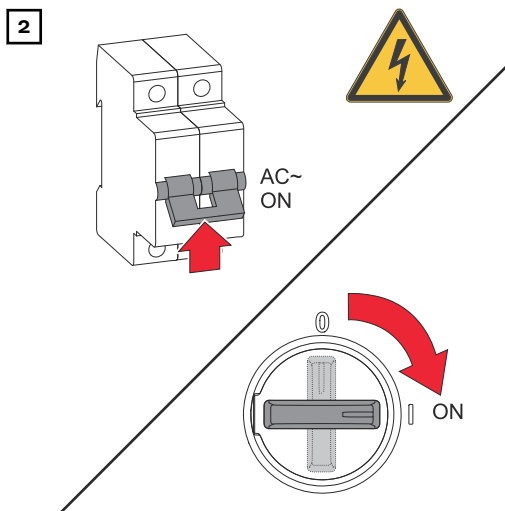

Set the DC disconnect to the "on" switch position.  
Turn on the automatic circuit breaker.

# PV Point Comfort

## Safety

### **WARNING!**

#### **Danger due to electrical voltage on live parts of the photovoltaic system.**

This can result in serious injury and damage to property.

- ▶ Disconnect live parts of the photovoltaic system on all pins and on all sides.
- ▶ Secure against re-activation in accordance with national regulations.
- ▶ Allow the capacitors of the inverter to discharge (2 minutes).
- ▶ Check that the inverter is de-energized with a suitable measuring device.

### **WARNING!**

#### **Danger due to work that has been carried out incorrectly.**

This can result in serious injury and damage to property.

- ▶ Installing and connecting an option must only be carried out by service personnel trained by Fronius and only within the scope of the respective technical regulations.
- ▶ Follow the safety rules.

### **WARNING!**

#### **Danger due to damaged and/or contaminated terminals.**

This can result in serious injury and damage to property.

- ▶ Before making any connections, check the terminals for damage and contamination.
- ▶ Remove contamination in the de-energized state.
- ▶ Have defective terminals repaired by an authorized specialist.

### **CAUTION!**

#### **Danger due to electrostatic discharge (ESD).**

This may result in damage to electronic components.

- ▶ Pay attention to the ESD marking on the product and/or on the packaging.
- ▶ Take ESD protection measures (grounding, neutralizing, and shielding).

### **NOTE!**

#### **The continuous supply via the PV Point depends on the available PV power.**

If the solar modules are not supplying enough power, interruptions may occur.

- ▶ Do not connect any loads that require an uninterruptible supply.

### **IMPORTANT!**

The valid national laws, standards, and provisions, as well as the specifications of the relevant grid operator are to be taken into account and applied.

It is highly recommended that the specific installation be agreed with the grid operator and explicitly approved by this operator. This obligation applies to system constructors in particular (e.g., installers).

### Scope of supply

The PV Point Comfort is available as an option and can be retrofitted to the inverter.

For technical data, see chapter [Technical data](#) on page 193.

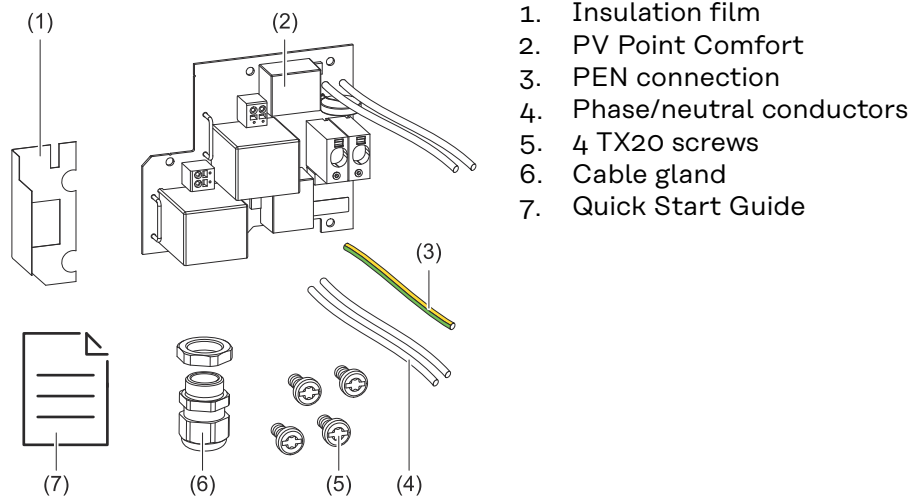

### De-energizing the inverter

1

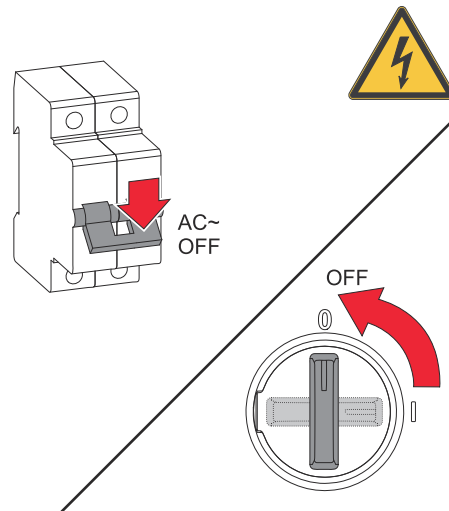

Turn off the automatic circuit breaker. Set the DC disconnector to the "off" switch position.

2

Disconnect connections from the solar module strings (+/-).

3

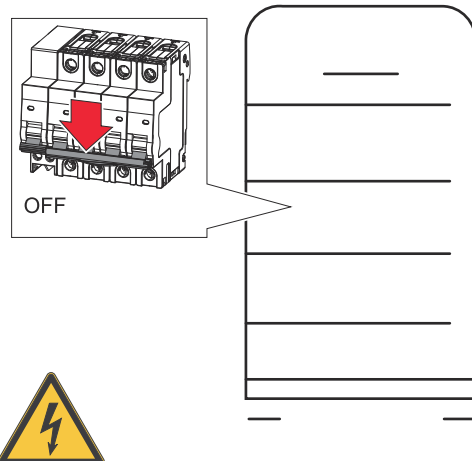

Disconnect connections from the solar module strings (+/-). Switch off the battery connected to the inverter.

Wait for the capacitors of the inverter to discharge (2 minutes).

## Installation

### CAUTION!

#### **Danger due to insufficiently dimensioned ground conductors.**

This may result in damage to the inverter due to thermal overload.

- The national standards and regulations must be observed for dimensioning of the ground conductor.

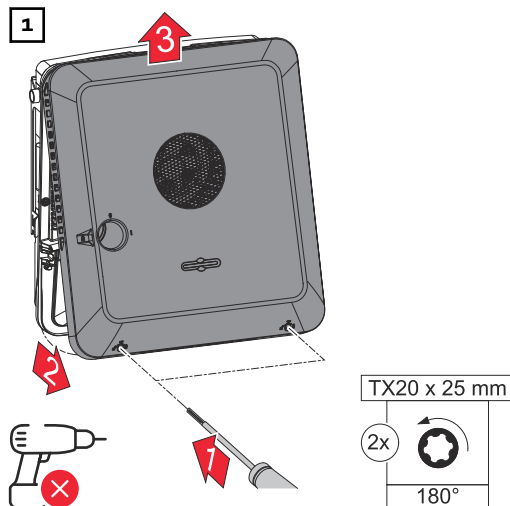

Loosen the 2 screws on the underside of the housing cover by rotating them 180° to the left using a screwdriver (TX20). Then lift the housing cover away from the inverter at the bottom and detach from above.

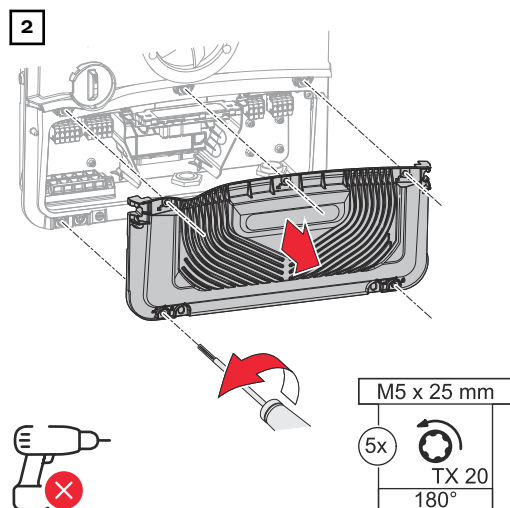

Loosen the 5 screws on the connection area cover by rotating them 180° to the left using a screwdriver (TX20). Remove the connection area cover from the device.

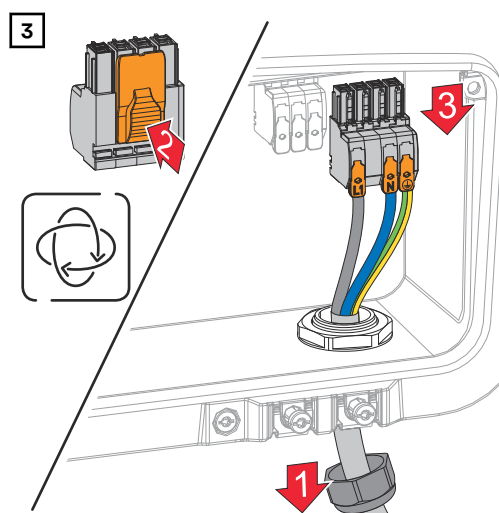

Press the latch on the back of the terminal and remove the AC terminals. Loosen the cable gland.

4

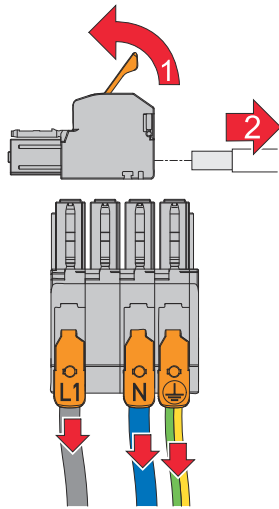

Disconnect the single conductors from the AC terminal (only necessary for an existing installation).

5

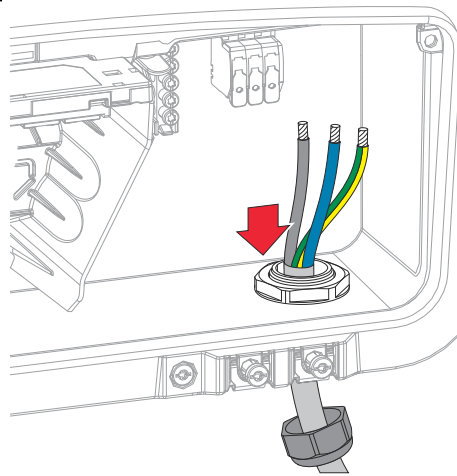

Remove the mains cable from the inverter.

6

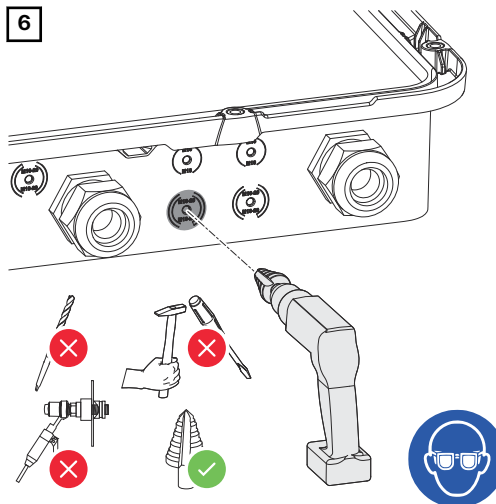

Drill out the optional cable gland with a step drill.

7

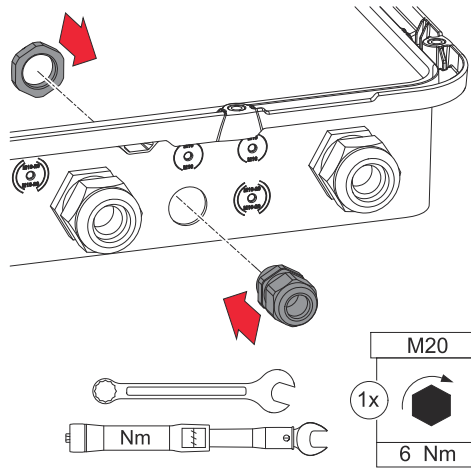

Insert the cable gland into the hole and fasten with a torque of 6 Nm.

8

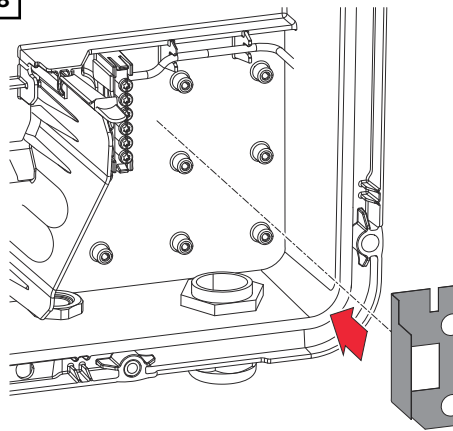

Insert the insulating film on the right side of the ground electrode terminal.

9

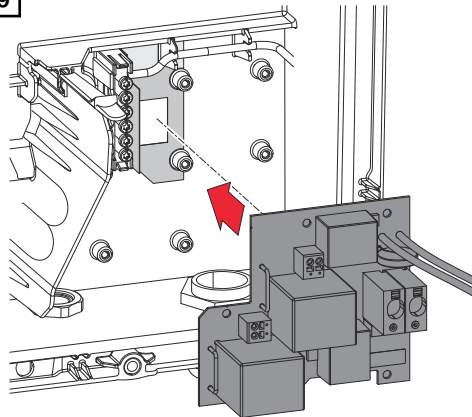

Insert the PC board into the inverter.

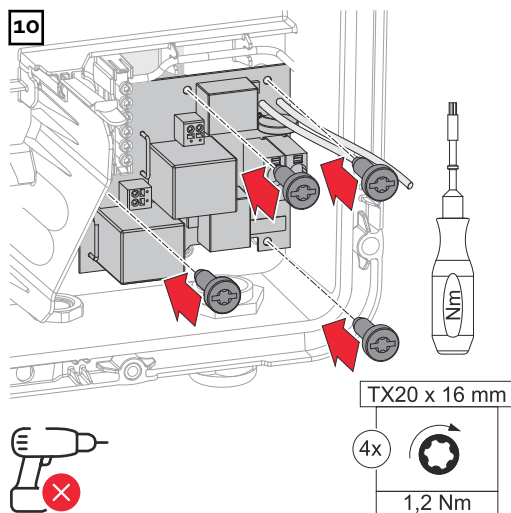

Fasten the PC board using the 4 screws supplied (TX20) and a torque of 1.2 Nm.

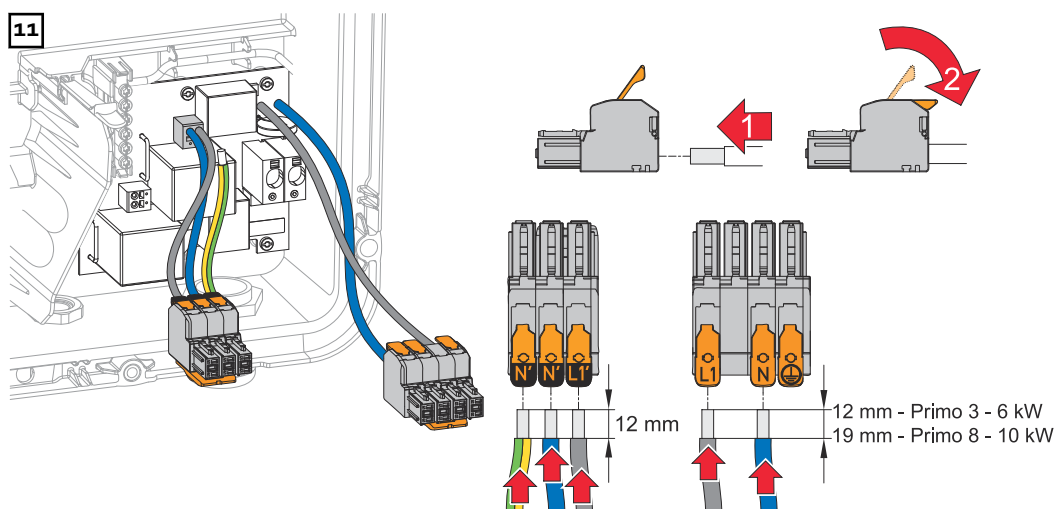



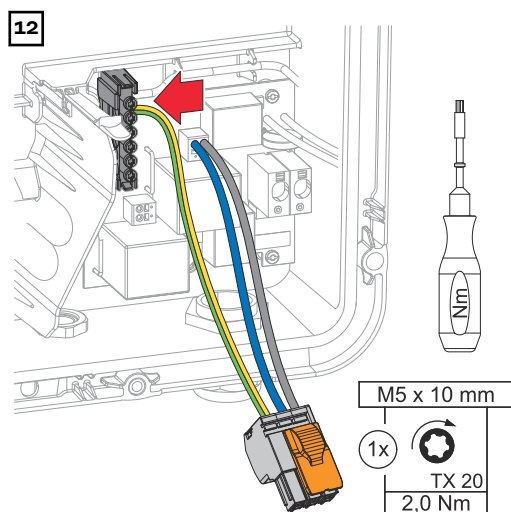

Strip the insulation of the single conductors (Primo 3 - 6 kW = 12 mm, Primo 8 - 10 kW = 19 mm). Lift to open the AC terminal's operating lever and insert the stripped single conductor into the slot provided on the AC terminal, all the way up to the stop. Then close the operating lever until it engages.

**IMPORTANT!**

The PEN connection must be established in accordance with national regulations. If necessary, the supplied PEN connection must be replaced.



Fasten the PEN conductor to the ground electrode terminal at the second input from above using a screwdriver (TX20) and a torque of 1.8 - 2 Nm.

13			
Inverter (AC~)		$\varnothing$	
Primo GEN24 3 - 6 kW	Cu	2,5 - 10 mm <sup>2</sup>	12 mm
Primo GEN24 8 - 10 kW	Cu	2,5 - 16 mm <sup>2</sup>	19 mm
PV Point		$\varnothing$	
	Cu	1,5 - 2,5 mm <sup>2</sup>	12 mm

Strip the insulation of the single conductors according to the specifications depending on the power category of the inverter.

The cable cross-section must be selected according to the specifications for the respective power category of the inverter (see chapter [Permissible cables for the electrical connection](#) on page 68).

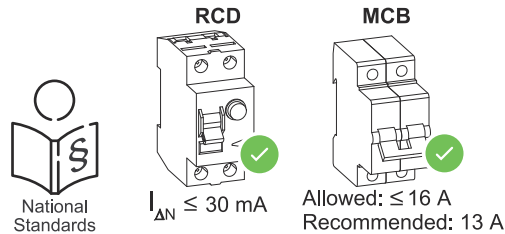

### IMPORTANT!

If necessary, an automatic circuit breaker with a maximum 16 A can also be used for fuse protection. A maximum of 13 A can be supplied in backup power mode. The residual current circuit breaker and automatic circuit breaker must be designed in accordance with the national regulations.

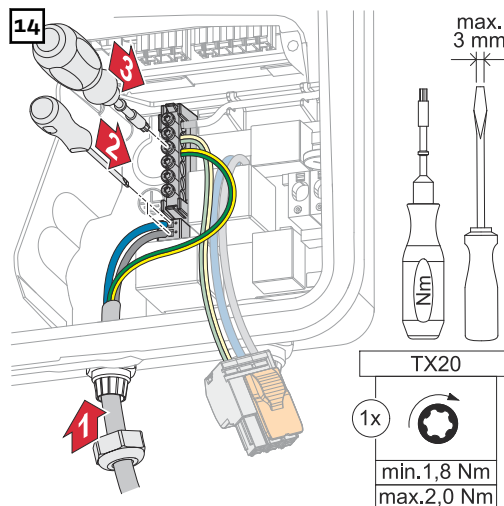

Connect the phase/neutral conductors to the terminals provided. Fasten the ground conductor to the ground electrode terminal at the third input from above using a screwdriver (TX20) and a torque of 1.8 - 2 Nm.

### IMPORTANT!

The ground conductor must be connected using a movement loop so that the ground conductor is disconnected last if the cable gland fails.

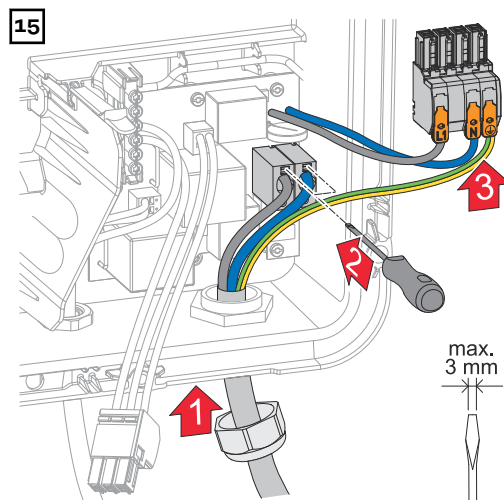

Connect the stripped phase/neutral conductors to the terminals provided.

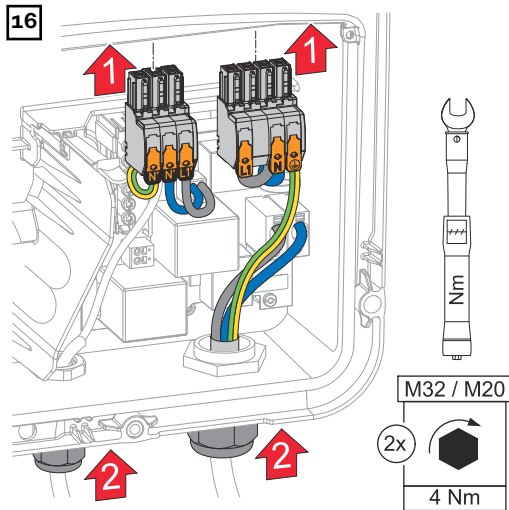

Insert the terminals into the respective slot until they engage. Fasten the union nuts of the cable glands with a torque of 4 Nm.

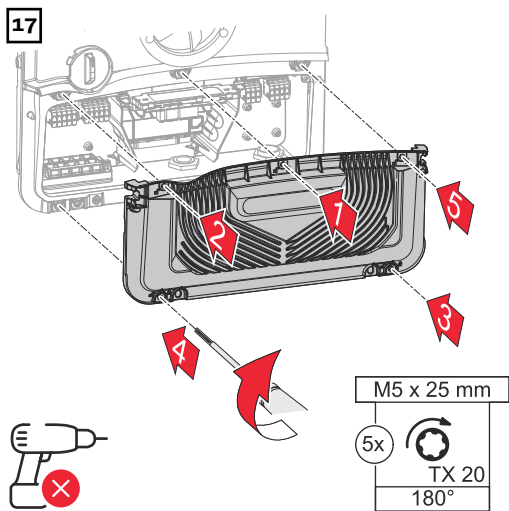

Place the cover on the connection area. Tighten the 5 screws by rotating them 180° to the right in the indicated order using a screwdriver (TX20).

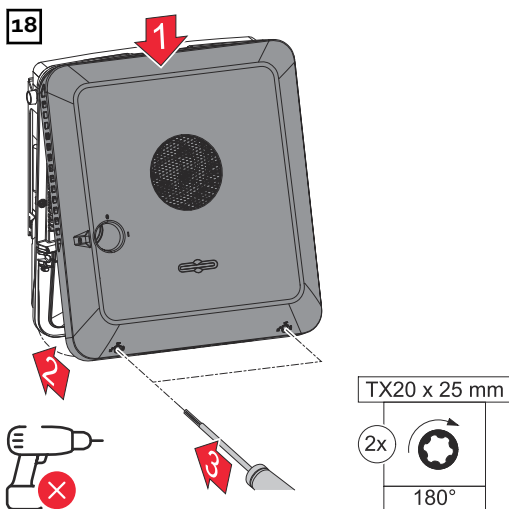

Clip the housing cover into the inverter from above. Press on the lower part of the housing cover and tighten the 2 screws by rotating them 180° to the right using a screwdriver (TX20).

## Starting up the inverter

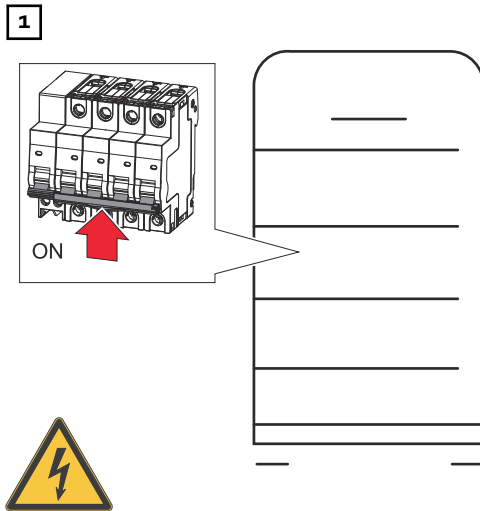

Connect the solar module strings (+/-). Switch on the battery connected to the inverter.

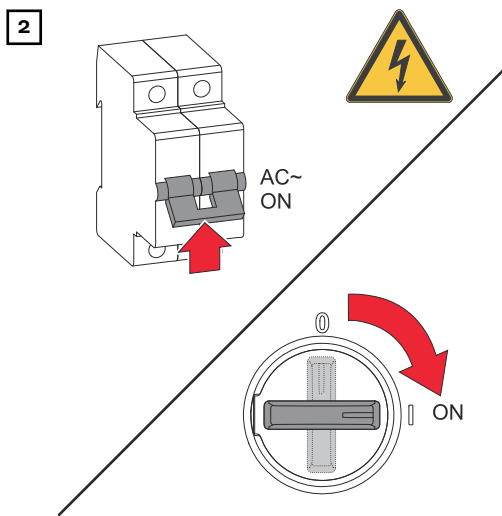

Set the DC disconnect to the "on" switch position. Turn on the automatic circuit breaker.

## Configuring the PV Point Comfort

Firmware version 1.25.2 or higher is required to commission the PV Point Comfort. Outdated firmware versions could lead to incompatibilities between the inverter and PV Point Comfort. In this case, the inverter firmware should be updated in accordance with the chapter headed [Update](#) on page 127.

- 1 Call up the user interface of the inverter.
    - Open web browser.
    - In the browser's address bar, enter the IP address (IP address for WLAN: 192.168.250.181, IP address for LAN: 169.254.0.180) or enter and confirm the host and domain name of the inverter.

✓ *The user interface of the inverter is displayed.*
  - 2 Click on the **Device Configuration** button.
  - 3 Log in to the login area with user **Technician** and the technician password.
  - 4 Go to the **Device Configuration > Functions and I/Os** menu area.
  - 5 Enable the **Backup Power** function.
  - 6 Select **PV Point** mode in the **Backup Power Mode** drop-down list.
  - 7 Click the **Save** button to save the settings.
- ✓ *The **PV Point** backup power mode has been configured.*

---

**Testing backup power mode**

Testing backup power mode is recommended:

- during first-time installation and configuration
- after working on the switch cabinet
- during ongoing operation (recommendation: at least every 6 months)

A battery charge of min. 30% is recommended for test mode.

A description of how to run the test mode can be found in the [checklist – Backup power](https://www.fronius.com/en/search-page) (https://www.fronius.com/en/search-page, item number: 42,0426,0365).



# Appendix



# Service, maintenance and disposal

---

**General** The inverter is designed so that it does not require additional maintenance work. Nevertheless, a few points must be considered during operation to ensure that the inverter works perfectly.

---

**Cleaning** Wipe the inverter, if necessary, with a damp cloth. Do not use cleaning agents, scouring agents, solvents, or similar products to clean the inverter.

---

**Maintenance** Maintenance and service work may only be carried out by a trained technician.

---

**Safety** The DC disconnect is used only to switch off power to the power stage set. When the DC disconnect is turned off, the connection area is still energized.

 **WARNING!**

**Danger from mains voltage and DC voltage from PV modules.**

This can result in severe personal injury and damage to property.

- ▶ The connection area must only be opened by an authorized electrician.
- ▶ The separate power stage set area must only be opened by Fronius-trained service technicians.
- ▶ Prior to any connection work, ensure that the inverter is de-energized on the AC side and the DC side.

 **WARNING!**

**Danger of residual voltage from capacitors.**

This can result in severe personal injury and damage to property.

- ▶ Allow the capacitors of the inverter to discharge (2 minutes).

**Operation in dusty environments**

**NOTE!**

**If the inverter is operated in dusty environments, dirt may build up on the heat sink and fan.**

This may result in a loss of power due to insufficient cooling of the inverter.

- ▶ Make sure that the ambient air can always flow through the inverter's ventilation slots unimpeded.
- ▶ Remove any build-ups of dirt from the heat sink and the fan.

1

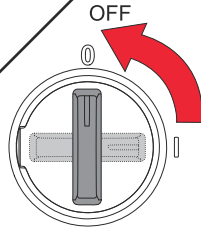
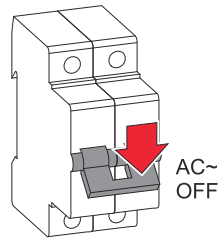

Switch off power to the inverter and wait for the specified time until the capacitors have discharged and the fan has shut down. Turn the DC disconnect to the "Off" switch setting.

2

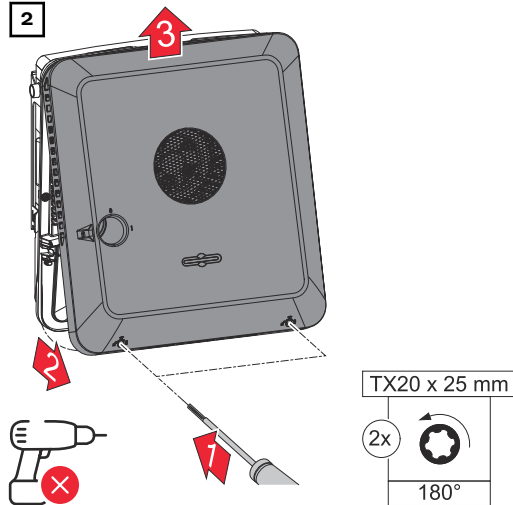

Loosen the screws on the underside of the housing cover by rotating them 180° to the left using a screwdriver (TX20). Then lift the housing cover away from the inverter at the bottom and detach from above.

3

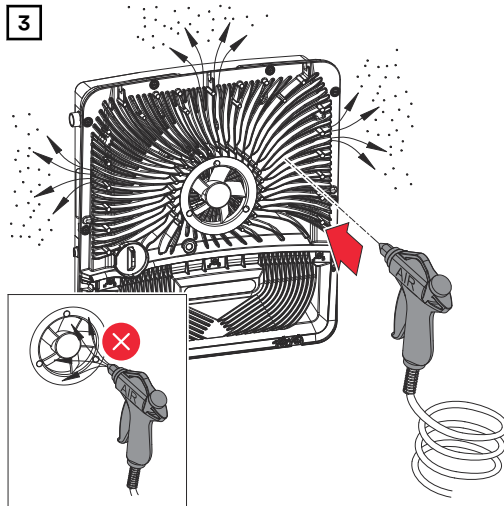

Remove any build-up of dirt on the heat sink and fan using compressed air, a cloth, or a brush.

**NOTE!**

**Risk due to damage to the fan bearing in the event of incorrect cleaning.**

Excessive speeds and the application of pressure to the fan bearing can cause damage.

- ▶ Block the fan and clean with compressed air.
- ▶ When using a cloth or brush, clean the fan without applying any pressure.

To start up the inverter again, follow the steps listed above in reverse order.

**Disposal**

Waste electrical and electronic equipment must be collected separately and recycled in an environmentally sound manner in accordance with the European Directive and national law. Used equipment must be returned to the distributor or through a local authorized collection and disposal system. Proper disposal of the

used device promotes sustainable recycling of resources and prevents negative effects on health and the environment.

**Packaging materials**

- Collect separately
- Observe local regulations
- Crush cardboard boxes

# Warranty provisions

---

## **Fronius manufacturer's warranty**

Detailed warranty conditions specific to your country can be found at [www.fronius.com/solar/garantie](http://www.fronius.com/solar/garantie).

To secure the full warranty period for the newly installed Fronius product, it is necessary to register at [www.solarweb.com](http://www.solarweb.com).

# Components for switching to backup power

Components for automatic backup power changeover to Full Backup

## Fronius components

Product	Item number
Fronius Smart Meter 63A-1	43,0001,1477
Fronius Smart Meter 50kA-3	43,0001,1478
Fronius Smart Meter TS 100A-1	43,0001,0045
Fronius Smart Meter TS 5kA-3	43,0001,0046
Fronius Smart Meter WR	43,0001,3591

## Third-party components

Manufacturers/types other than the product examples listed are permissible, provided that they meet the same technical and functional requirements.

### Grid and system protection

Manufacturer/type	Bender GmbH & Co. KG VMD460-NA-D-2 Tele Haase Steuergeräte Ges.m.b.H. RE-NA003-M64
-------------------	---

### K1 and K2 - Installation contactor with auxiliary contact

Number of pins	1-pin or 2-pin (depending on the cabling variant)
Rated current	depending on the house connection
Coil voltage	230 V AC
Rated frequency	50/60 Hz
Coil fuse	6 A
Min. short circuit current	3 kA (contacts)
Test standard	IEC 60947-4-1

### Auxiliary contact

Number of NC contacts	1
Switching voltage	12 - 230 V @ 50 / 60 Hz
Min. nominal current	1 A
Min. short circuit current	1 kA
Manufacturer/type	ISKRA IK63-40 / Schrack BZ326461

### Buffer power supply - Fault Ride Through cabling variant

Manufacturer/type	BKE JS-20-240/DIN_BUF
-------------------	-----------------------

<b>K1 and K2 - DC installation contactor with auxiliary contact (Fault Ride Through)</b>	
Number of pins	1-pin or 2-pin (depending on the cabling variant)
Rated current	depending on the house connection
Coil voltage	24 V <sub>DC</sub>
Min. short circuit current	3 kA (contacts)
Test standard	IEC 60947-4-1
<b>Auxiliary contact</b>	
Number of NC contacts	1
Switching voltage	24 V <sub>DC</sub>
Min. nominal current	1 A
Min. short circuit current	1 kA
Manufacturer/type	Finder 22.64.0.024.4710

<b>K3 - Modular relay</b>	
Number of changeover contacts	2
Coil voltage	12 V DC
Test standard	IEC 60947-4-1
Manufacturer/type	Finder 22.23.9.012.4000 / Schrack relay RT424012 (bracket RT17017, relay base RT78725)

<b>K4 and K5 - Installation contactor</b>	
Number of NC contacts	2 (25 A)
Coil voltage	230 V AC (2P)
Rated frequency	50/60 Hz
Coil fuse	6 A
Min. short circuit current	3 kA (contacts)
Test standard	IEC 60947-4-1
Manufacturer/type	ISKRA IKA225-02

**Components for manual backup power changeover to Full Backup**

<b>Product</b>	<b>Item number</b>
Fronius Smart Meter 63A-1	43,0001,1477
Fronius Smart Meter TS 100A-1	43,0001,0045
Fronius Backup Switch 1P/3P-63A	4,050,221
Fronius Backup Switch 1PN/3PN-63A	4,050,220

# Status codes and remedy

## Display

Status codes are displayed on the user interface of the inverter in the **System > Event Log** menu area or in the user menu under **Notifications** and in Fronius Solar.web\*.

\* If configured accordingly, see chapter [Fronius Solar.web](#) on page 19.

## Status codes

### 1006 – ArcDetected (operating LED: flashes yellow)

Cause: An electric arc has been identified on the PV system.

Remedy: No action required. The supply of energy from the inverter into the grid is automatically started again after 5 minutes.

### 1030 – WSD Open (operating LED: flashes red)

Cause: A device that is connected in the WSD chain has interrupted the signal line (e.g., surge protection device) or the bypass installed ex works as standard has been removed and no trigger device has been installed.

Remedy: If the SPD surge protection device has tripped, the inverter must be repaired by an authorized specialist.

OR: Install the bypass installed ex works as standard or a trigger device.

OR: Turn the WSD (wired shutdown) switch to position 1 (WSD primary device).

#### **WARNING!**

##### **Danger from work that is not carried out properly.**

This can result in serious injury and damage to property.

- ▶ The installation and connection of an SPD surge protection device may only be carried out by Fronius-trained service personnel in accordance with the technical specifications.
- ▶ Observe safety rules.

### 1173 – ArcContinuousFault (operating LED: flashes red)

Cause: An electric arc has been identified on the PV system, and the maximum number of automatic connections within 24 hours has been reached.

Remedy: Keep the sensor pressed on the inverter for 3 seconds (max. 6 seconds).

OR: On the user interface of the inverter, in the **System > Event Log** menu area, confirm the status **1173 - ArcContinuousFault**.

OR: On the user interface of the inverter, in the **Notifications** user menu, confirm the status **1173 - ArcContinuousFault**.

#### **CAUTION!**

##### **Danger from damaged components of the PV system**

Serious personal injury/damage to property may result.

- ▶ Before the status **1173 - ArcContinuousFault** is confirmed, the entire photovoltaic system affected must be checked for any possible damage.
- ▶ Damaged components must be repaired by qualified specialists.

---

**1191 – AfcIDataTransfer (operating LED: flashes yellow)**

Cause: An electric arc has been identified on the PV system.

Remedy: No action required.

---

# Technical data

## Fronius Primo GEN24 3.0 SC / 3.0 Plus SC

DC input data	
MPP voltage range (at rated power)	190-480 V
Max. connected load ( $P_{PV \max}$ )	
Total	4,500 Wp
PV 1	4,500 Wp
PV 2	4,500 Wp
Max. processable PV power	
Total	3,110 Wp
PV 1	3,110 Wp
PV 2	3,110 Wp
Max. input voltage at 1,000 W/m <sup>2</sup> /-10 °C in an open circuit	600 V
Min. input voltage	65 V
Feed-in start-up input voltage in grid operation <sup>5)</sup>	80 V
Max. input current	
PV 1	22.0 A
PV 2	16.0 A
Max. short circuit current for module array ( $I_{SC \text{ PV}}$ )	
PV 1	44 A
PV 2	32 A
Max. total short circuit current for module array ( $I_{SC \text{ PV1}} + I_{SC \text{ PV2}} = I_{SC \text{ max}}$ )	76 A
Max. inverter backfeed current to the array <sup>3)</sup>	
PV 1	44 A
PV 2	32 A
Number of inputs—PV 1	2
Number of inputs—PV 2	2
Max. capacity of the PV generator against ground	
Total	600 nF
PV 1	600 nF
PV 2	600 nF
Limit value of the insulation resistance test between module array and ground (on delivery) <sup>10)</sup>	100 k $\Omega$
Adjustable range of insulation resistance test between module array and ground <sup>9)</sup>	10-10,000 k $\Omega$

DC input data	
Limit value and trip time of sudden residual fault current monitoring (on delivery)	30 / 300 mA / ms 60 / 150 mA / ms 90 / 40 mA / ms
Limit value and trip time of continuous residual fault current monitoring (on delivery)	300 / 300 mA / ms
Adjustable range of continuous residual current monitoring <sup>9)</sup>	30-300 mA
Cyclic repetition of the insulation resistance test (on delivery)	24 h
Adjustable range for cyclic repetition of the insulation resistance test	-

DC input data battery	
Max. voltage	465 V
Min. voltage	150 V
Max. current	22 A
Max. output	3,000 W
DC inputs	1

AC input/output data	
Rated power ( $P_{nom}$ )	3,000 W
Max. output power	3,000 W
Rated apparent power	3,000 VA
Nominal mains voltage	1 ~ NPE 220 V / 230 V / 240 V
Min. mains voltage	155 V <sup>1)</sup>
Max. mains voltage	270 V <sup>1)</sup>
Max. output current	19.4 A
Current (inrush) <sup>6)</sup>	20 A / 1.3 ms
Nominal frequency	50 / 60 Hz <sup>1)</sup>
Initial symmetrical short-circuit current / phase $I_K''$	19.4 A
Nominal frequency for Full Backup	53 / 63 Hz <sup>1)</sup>
Total harmonic distortion	< 2%
Power factor $\cos \phi$ <sup>2)</sup>	0.8-1 (adjustable)
Max. permitted grid impedance $Z_{max}$ on PCC <sup>4)</sup>	None
Max. output fault current / duration	29 A / 3 ms

AC output data PV Point / PV Point Comfort	
Max. output power	4,133 W (for 5 s)
Rated power	3,000 W

AC output data PV Point / PV Point Comfort	
Rated output current	13 A
Nominal mains voltage	1 ~ NPE 220 V / 230 V / 240 V
Nominal frequency	53 / 63 Hz <sup>1)</sup>
Switching time	~ 15 s
Power factor cos phi <sup>2)</sup>	0-1

AC output data Full Backup	
Max. output power	4,133 W (for 5 s)
Rated power	3,000 W
Rated output current	13 A
Nominal mains voltage	1 ~ NPE 220 V / 230 V / 240 V
Nominal frequency for Full Backup	53 / 63 Hz <sup>1)</sup>
Switching time	~ 10 s
Power factor cos phi <sup>2)</sup>	0-1

General data	
Max. efficiency	97.7%
Europ. efficiency ( $U_{mpp\ nom}$ )	96.7%
Europ. efficiency ( $U_{mpp\ max}$ )	96.2%
Europ. efficiency ( $U_{mpp\ min}$ )	95.7%
Self-consumption at night	8.2 W
Cooling	Controlled forced-air ventilation
Protection class	IP 66
Dimensions H × W × D	530 × 474 × 165 millimeters
Weight	15.2 kg
Inverter topology	Non-insulated, no transformer
Permitted ambient temperature	-40 °C-+60 °C
Permissible humidity	0-100% (incl. condensation)
EMC emission class (in accordance with IEC 61000-6-2, IEC 61000-6-3)	B
DC / AC overvoltage category (in accordance with IEC 62109-1)	2 / 3
Pollution degree	2
Sound pressure level	42 dB(A) (ref. 20μPa)
Safety class (in accordance with IEC62103)	1

Protection devices	
DC isolation measurement <sup>11)</sup>	Warning/shutdown at $R_{ISO} < 100\ k\Omega$

Protection devices	
Overload performance	Operating point shift, power limit
DC disconnect	Integrated
RCMU <sup>11)</sup>	Integrated
RCMU classification	The software class of the safety platform(s) is defined as a class B control function (single-channel with periodic self-test) in accordance with IEC 60730 Annex H.
Active anti-islanding method	Frequency shift method
AFCI	Integrated
AFPE (AFCI) classification (in accordance with IEC 63027) <sup>11)</sup>	= F-I-AFPE-1-4-1 Full coverage Integrated AFPE 1 monitored string per input port 4 input ports per channel (MPP1: 2, MPP2: 2) 1 monitored channel
AFPE (AFCI) classification in use with the option DC Connector Kit GEN24 (in accordance with IEC 63027) <sup>11)</sup>	= F-I-AFPE-2-2-1 Full coverage Integrated AFPE 2 monitored strings per input port 2 input ports per channel (MPP1: 1, MPP2: 1) 1 monitored channel

Data communication	
WiFi SMA-RP connection ( <b>FCC ID:</b> QKWPILOT01 / <b>IC ID:</b> 12270A-PILOT01)	802.11b/g/n (WPA, WPA2) Frequency: 2.4 GHz
Ethernet (LAN)	RJ45, 10/100 Mbit
Wired shutdown (WSD)	Max. 28 devices/WSD chain Max. distance between two devices = 100 m
Modbus RTU SunSpec (2x)	RS485 2-wire
Voltage level of digital inputs	Low: min. 0 V-max. 1.8 V High: min. 4.5 V-max. 28.8 V
Input currents of digital inputs	Depending on the input voltage; input resistance = 70 kOhm
Total power for digital output (internal supply)	6 W at 12 V (USB not connected)
Power per digital output (external supply)	1 A at >12.5 V-24 V (max. 3 A in total)
Datalogger/web server	Integrated

**Fronius Primo  
GEN24 3.6 SC /  
3.6 Plus SC**

DC input data	
MPP voltage range (at rated power)	190-480 V
Max. connected load ( $P_{PV \max}$ )	
Total	5,600 Wp
PV 1	5,600 Wp
PV 2	5,600 Wp
Max. processable PV power	
Total	3,810 Wp
PV 1	3,810 Wp
PV 2	3,810 Wp
Max. input voltage at 1,000 W/m <sup>2</sup> /-10 °C in an open circuit	600 V
Min. input voltage	65 V
Feed-in start-up input voltage in grid operation <sup>5)</sup>	80 V
Max. input current	
PV 1	22.0 A
PV 2	16.0 A
Max. short circuit current for module array ( $I_{SC \text{ PV}}$ )	
PV 1	44 A
PV 2	32 A
Max. total short circuit current for module array ( $I_{SC \text{ PV1}} + I_{SC \text{ PV2}} = I_{SC \text{ max}}$ )	76 A
Max. inverter backfeed current to the array <sup>3)</sup>	
PV 1	44 A
PV 2	32 A
Number of inputs—PV 1	2
Number of inputs—PV 2	2
Max. capacity of the PV generator against ground	
Total	740 nF
PV 1	740 nF
PV 2	740 nF
Limit value of the insulation resistance test between module array and ground (on delivery) <sup>10)</sup>	100 kΩ
Adjustable range of insulation resistance test between module array and ground <sup>9)</sup>	10-10,000 kΩ
Limit value and trip time of sudden residual fault current monitoring (on delivery)	30 / 300 mA / ms 60 / 150 mA / ms 90 / 40 mA / ms

<b>DC input data</b>	
Limit value and trip time of continuous residual fault current monitoring (on delivery)	300 / 300 mA / ms
Adjustable range of continuous residual current monitoring <sup>9)</sup>	30-300 mA
Cyclic repetition of the insulation resistance test (on delivery)	24 h
Adjustable range for cyclic repetition of the insulation resistance test	-

<b>DC input data battery</b>	
Max. voltage	465 V
Min. voltage	150 V
Max. current	22 A
Max. output	3,680 W
DC inputs	1

<b>AC input/output data</b>	
Rated power ( $P_{nom}$ )	3,680 W
Max. output power	3,680 W
Rated apparent power	3,680 VA
Nominal mains voltage	1 ~ NPE 220 V / 230 V / 240 V
Min. mains voltage	155 V <sup>1)</sup>
Max. mains voltage	270 V <sup>1)</sup>
Max. output current	23.7 A
Current (inrush) <sup>6)</sup>	20 A / 1.3 ms
Nominal frequency	50 / 60 Hz <sup>1)</sup>
Initial symmetrical short-circuit current / phase $I_K''$	23.7 A
Nominal frequency for Full Backup	53 / 63 Hz <sup>1)</sup>
Total harmonic distortion	< 2%
Power factor $\cos \phi$ <sup>2)</sup>	0.8-1 (adjustable)
Max. permitted grid impedance $Z_{max}$ on PCC <sup>4)</sup>	None
Max. output fault current / duration	29 A / 3 ms

<b>AC output data PV Point / PV Point Comfort</b>	
Max. output power	4,133 W (for 5 s)
Rated power	3,000 W
Rated output current	13 A
Nominal mains voltage	1 ~ NPE 220 V / 230 V / 240 V

AC output data PV Point / PV Point Comfort	
Nominal frequency	53 / 63 Hz <sup>1)</sup>
Switching time	~ 15 s
Power factor cos phi <sup>2)</sup>	0-1

AC output data Full Backup	
Max. output power	5,070 W (for 5 s)
Rated power	3,680 W
Rated output current	16 A
Nominal mains voltage	1 ~ NPE 220 V / 230 V / 240 V
Nominal frequency for Full Backup	53 / 63 Hz <sup>1)</sup>
Switching time	~ 10 s
Power factor cos phi <sup>2)</sup>	0-1

General data	
Max. efficiency	97.7%
Europ. efficiency ( $U_{mpp\ nom}$ )	97.0%
Europ. efficiency ( $U_{mpp\ max}$ )	96.5%
Europ. efficiency ( $U_{mpp\ min}$ )	96.0%
Self-consumption at night	8.2 W
Cooling	Controlled forced-air ventilation
Protection class	IP 66
Dimensions H × W × D	530 × 474 × 165 millimeters
Weight	15.2 kg
Inverter topology	Non-insulated, no transformer
Permitted ambient temperature	-40 °C-+60 °C
Permissible humidity	0-100% (incl. condensation)
EMC emission class (in accordance with IEC 61000-6-2, IEC 61000-6-3)	B
DC / AC overvoltage category (in accordance with IEC 62109-1)	2 / 3
Pollution degree	2
Sound pressure level	42 dB(A) (ref. 20μPa)
Safety class (in accordance with IEC62103)	1

Protection devices	
DC isolation measurement <sup>11)</sup>	Warning/shutdown at $R_{ISO} < 100\ k\Omega$
Overload performance	Operating point shift, power limit
DC disconnect	Integrated

Protection devices	
RCMU <sup>11)</sup>	Integrated
RCMU classification	The software class of the safety platform(s) is defined as a class B control function (single-channel with periodic self-test) in accordance with IEC 60730 Annex H.
Active anti-islanding method	Frequency shift method
AFCI	Integrated
AFPE (AFCI) classification (in accordance with IEC 63027) <sup>11)</sup>	= F-I-AFPE-1-4-1 Full coverage Integrated AFPE 1 monitored string per input port 4 input ports per channel (MPP1: 2, MPP2: 2) 1 monitored channel
AFPE (AFCI) classification in use with the option DC Connector Kit GEN24 (in accordance with IEC 63027) <sup>11)</sup>	= F-I-AFPE-2-2-1 Full coverage Integrated AFPE 2 monitored strings per input port 2 input ports per channel (MPP1: 1, MPP2: 1) 1 monitored channel

Data communication	
WiFi SMA-RP connection ( <b>FCC ID:</b> QKWPILOT01 / <b>IC ID:</b> 12270A-PILOT01)	802.11b/g/n (WPA, WPA2) Frequency: 2.4 GHz
Ethernet (LAN)	RJ45, 10/100 Mbit
Wired shutdown (WSD)	Max. 28 devices/WSD chain Max. distance between two devices = 100 m
Modbus RTU SunSpec (2x)	RS485 2-wire
Voltage level of digital inputs	Low: min. 0 V-max. 1.8 V High: min. 4.5 V-max. 28.8 V
Input currents of digital inputs	Depending on the input voltage; Input resistance = 70 kOhm
Total power for digital output (internal supply)	6 W at 12 V (USB not connected)
Power per digital output (external supply)	1 A at >12.5 V-24 V (max. 3 A in total)
Datalogger/web server	Integrated

**Fronius Primo  
GEN24 4.0 SC /  
4.0 Plus SC**

DC input data	
MPP voltage range (at rated power)	190-480 V

DC input data	
Max. connected load ( $P_{PV \max}$ )	
Total	6,000 Wp
PV 1	6,000 Wp
PV 2	6,000 Wp
Max. processable PV power	
Total	4,140 Wp
PV 1	4,140 Wp
PV 2	4,140 Wp
Max. input voltage at 1,000 W/m <sup>2</sup> /-10 °C in an open circuit	600 V
Min. input voltage	65 V
Feed-in start-up input voltage in grid operation <sup>5)</sup>	80 V
Max. input current	
PV 1	22.0 A
PV 2	16.0 A
Max. short circuit current for module array ( $I_{SC \text{ PV}}$ )	
PV 1	44 A
PV 2	32 A
Max. total short circuit current for module array ( $I_{SC \text{ PV1}} + I_{SC \text{ PV2}} = I_{SC \text{ max}}$ )	76 A
Max. inverter backfeed current to the array <sup>3)</sup>	
PV 1	44 A
PV 2	32 A
Number of inputs—PV 1	2
Number of inputs—PV 2	2
Max. capacity of the PV generator against ground	
Total	800 nF
PV 1	800 nF
PV 2	800 nF
Limit value of the insulation resistance test between module array and ground (on delivery) <sup>10)</sup>	100 kΩ
Adjustable range of insulation resistance test between module array and ground <sup>9)</sup>	10-10,000 kΩ
Limit value and trip time of sudden residual fault current monitoring (on delivery)	30 / 300 mA / ms 60 / 150 mA / ms 90 / 40 mA / ms
Limit value and trip time of continuous residual fault current monitoring (on delivery)	300 / 300 mA / ms
Adjustable range of continuous residual current monitoring <sup>9)</sup>	30-300 mA

DC input data	
Cyclic repetition of the insulation resistance test (on delivery)	24 h
Adjustable range for cyclic repetition of the insulation resistance test	-

DC input data battery	
Max. voltage	465 V
Min. voltage	150 V
Max. current	22 A
Max. output	4,000 W
DC inputs	1

AC input/output data	
Rated power ( $P_{nom}$ )	4,000 W
Max. output power	4,000 W
Rated apparent power	4,000 VA
Nominal mains voltage	1 ~ NPE 220 V / 230 V / 240 V
Min. mains voltage	155 V <sup>1)</sup>
Max. mains voltage	270 V <sup>1)</sup>
Max. output current	25.8 A
Current (inrush) <sup>6)</sup>	20 A / 1.3 ms
Nominal frequency	50 / 60 Hz <sup>1)</sup>
Initial symmetrical short-circuit current / phase $I_K''$	25.8 A
Nominal frequency for Full Backup	53 / 63 Hz <sup>1)</sup>
Total harmonic distortion	< 2%
Power factor $\cos \phi$ <sup>2)</sup>	0.8-1 (adjustable)
Max. permitted grid impedance $Z_{max}$ on PCC <sup>4)</sup>	None
Max. output fault current / duration	29 A / 3 ms

AC output data PV Point / PV Point Comfort	
Max. output power	4,133 W (for 5 s)
Rated power	3,000 W
Rated output current	13 A
Nominal mains voltage	1 ~ NPE 220 V / 230 V / 240 V
Nominal frequency	53 / 63 Hz <sup>1)</sup>
Switching time	~ 15 s
Power factor $\cos \phi$ <sup>2)</sup>	0-1

<b>AC output data Full Backup</b>	
Max. output power	5,510 W (for 5 s)
Rated power	4,000 W
Rated output current	17.4 A
Nominal mains voltage	1 ~ NPE 220 V / 230 V / 240 V
Nominal frequency for Full Backup	53 / 63 Hz <sup>1)</sup>
Switching time	~ 10 s
Power factor cos phi <sup>2)</sup>	0-1

<b>General data</b>	
Max. efficiency	97.7%
Europ. efficiency ( $U_{mpp\ nom}$ )	97.1%
Europ. efficiency ( $U_{mpp\ max}$ )	96.7%
Europ. efficiency ( $U_{mpp\ min}$ )	96.1%
Self-consumption at night	8.2 W
Cooling	Controlled forced-air ventilation
Protection class	IP 66
Dimensions H × W × D	530 × 474 × 165 millimeters
Weight	15.2 kg
Inverter topology	Non-insulated, no transformer
Permitted ambient temperature	-40 °C +60 °C
Permissible humidity	0-100% (incl. condensation)
EMC emission class (in accordance with IEC 61000-6-2, IEC 61000-6-3)	B
DC / AC overvoltage category (in accordance with IEC 62109-1)	2 / 3
Pollution degree	2
Sound pressure level	42 dB(A) (ref. 20μPa)
Safety class (in accordance with IEC62103)	1

<b>Protection devices</b>	
DC isolation measurement <sup>11)</sup>	Warning/shutdown at $R_{ISO} < 100\ k\Omega$
Overload performance	Operating point shift, power limit
DC disconnecter	Integrated
RCMU <sup>11)</sup>	Integrated
RCMU classification	The software class of the safety platform(s) is defined as a class B control function (single-channel with periodic self-test) in accordance with IEC 60730 Annex H.

Protection devices	
Active anti-islanding method	Frequency shift method
AFCI	Integrated
AFPE (AFCI) classification (in accordance with IEC 63027) <sup>11)</sup>	= F-I-AFPE-1-4-1 Full coverage Integrated AFPE 1 monitored string per input port 4 input ports per channel (MPP1: 2, MPP2: 2) 1 monitored channel
AFPE (AFCI) classification in use with the option DC Connector Kit GEN24 (in accordance with IEC 63027) <sup>11)</sup>	= F-I-AFPE-2-2-1 Full coverage Integrated AFPE 2 monitored strings per input port 2 input ports per channel (MPP1: 1, MPP2: 1) 1 monitored channel

Data communication	
WiFi SMA-RP connection ( <b>FCC ID:</b> QKWPILOT01 / <b>IC ID:</b> 12270A-PILOT01)	802.11b/g/n (WPA, WPA2) Frequency: 2.4 GHz
Ethernet (LAN)	RJ45, 10/100 Mbit
Wired shutdown (WSD)	Max. 28 devices/WSD chain Max. distance between two devices = 100 m
Modbus RTU SunSpec (2x)	RS485 2-wire
Voltage level of digital inputs	Low: min. 0 V-max. 1.8 V High: min. 4.5 V-max. 28.8 V
Input currents of digital inputs	Depending on the input voltage; input resistance = 70 kOhm
Total power for digital output (internal supply)	6 W at 12 V (USB not connected)
Power per digital output (external supply)	1 A at >12.5 V-24 V (max. 3 A in total)
Datalogger/web server	Integrated

**Fronius Primo  
GEN24 4.6 SC /  
4.6 Plus SC**

DC input data	
MPP voltage range (at rated power)	190-480 V
Max. connected load ( $P_{PV \max}$ )	
Total	6,900 Wp
PV 1	6,900 Wp
PV 2	6,900 Wp

DC input data	
Max. processable PV power Total PV 1 PV 2	4,750 Wp 4,750 Wp 4,750 Wp
Max. input voltage at 1,000 W/m <sup>2</sup> /-10 °C in an open circuit	600 V
Min. input voltage	65 V
Feed-in start-up input voltage in grid operation <sup>5)</sup>	80 V
Max. input current PV 1 PV 2	22.0 A 16.0 A
Max. short circuit current for module array ( $I_{SC\ PV}$ ) PV 1 PV 2	44 A 32 A
Max. total short circuit current for module array ( $I_{SC\ PV1} + I_{SC\ PV2} = I_{SC\ max}$ )	76 A
Max. inverter backfeed current to the array <sup>3)</sup> PV 1 PV 2	44 A 32 A
Number of inputs—PV 1	2
Number of inputs—PV 2	2
Max. capacity of the PV generator against ground Total PV 1 PV 2	920 nF 920 nF 920 nF
Limit value of the insulation resistance test between module array and ground (on delivery) <sup>10)</sup>	100 kΩ
Adjustable range of insulation resistance test between module array and ground <sup>9)</sup>	10-10,000 kΩ
Limit value and trip time of sudden residual fault current monitoring (on delivery)	30 / 300 mA / ms 60 / 150 mA / ms 90 / 40 mA / ms
Limit value and trip time of continuous residual fault current monitoring (on delivery)	300 / 300 mA / ms
Adjustable range of continuous residual current monitoring <sup>9)</sup>	30-300 mA
Cyclic repetition of the insulation resistance test (on delivery)	24 h
Adjustable range for cyclic repetition of the insulation resistance test	-

DC input data battery	
Max. voltage	465 V
Min. voltage	150 V
Max. current	22 A
Max. output	4,600 W
DC inputs	1

AC input/output data	
Rated power ( $P_{nom}$ )	4,600 W
Max. output power	4,600 W
Rated apparent power	4,600 VA
Nominal mains voltage	1 ~ NPE 220 V / 230 V / 240 V
Min. mains voltage	155 V <sup>1)</sup>
Max. mains voltage	270 V <sup>1)</sup>
Max. output current	27.5 A
Current (inrush) <sup>6)</sup>	20 A / 1.3 ms
Nominal frequency	50 / 60 Hz <sup>1)</sup>
Initial symmetrical short-circuit current / phase $I_{K''}$	27.5 A
Nominal frequency for Full Backup	53 / 63 Hz <sup>1)</sup>
Total harmonic distortion	< 2%
Power factor $\cos \phi$ <sup>2)</sup>	0.8-1 (adjustable)
Max. permitted grid impedance $Z_{max}$ on PCC <sup>4)</sup>	None
Max. output fault current / duration	29 A / 3 ms

AC output data PV Point / PV Point Comfort	
Max. output power	4,133 W (for 5 s)
Rated power	3,000 W
Rated output current	13 A
Nominal mains voltage	1 ~ NPE 220 V / 230 V / 240 V
Nominal frequency	53 / 63 Hz <sup>1)</sup>
Switching time	~ 15 s
Power factor $\cos \phi$ <sup>2)</sup>	0-1

AC output data Full Backup	
Max. output power	6,338 W (for 5 s)
Rated power	4,600 W
Rated output current	20 A
Nominal mains voltage	1 ~ NPE 220 V / 230 V / 240 V

<b>AC output data Full Backup</b>	
Nominal frequency for Full Backup	53 / 63 Hz <sup>1)</sup>
Switching time	~ 10 s
Power factor cos phi <sup>2)</sup>	0-1

<b>General data</b>	
Max. efficiency	97.7%
Europ. efficiency (U <sub>mpp nom</sub> )	97.2%
Europ. efficiency (U <sub>mpp max</sub> )	96.8%
Europ. efficiency (U <sub>mpp min</sub> )	96.4%
Self-consumption at night	8.2 W
Cooling	Controlled forced-air ventilation
Protection class	IP 66
Dimensions H × W × D	530 × 474 × 165 millimeters
Weight	15.2 kg
Inverter topology	Non-insulated, no transformer
Permitted ambient temperature	-40 °C - +60 °C
Permissible humidity	0-100% (incl. condensation)
EMC emission class (in accordance with IEC 61000-6-2, IEC 61000-6-3)	B
DC / AC overvoltage category (in accordance with IEC 62109-1)	2 / 3
Pollution degree	2
Sound pressure level	42 dB(A) (ref. 20μPa)
Safety class (in accordance with IEC62103)	1

<b>Protection devices</b>	
DC isolation measurement <sup>11)</sup>	Warning/shutdown at R <sub>ISO</sub> < 100 kOhm
Overload performance	Operating point shift, power limit
DC disconnecter	Integrated
RCMU <sup>11)</sup>	Integrated
RCMU classification	The software class of the safety platform(s) is defined as a class B control function (single-channel with periodic self-test) in accordance with IEC 60730 Annex H.
Active anti-islanding method	Frequency shift method
AFCI	Integrated

Protection devices	
AFPE (AFCI) classification (in accordance with IEC 63027) <sup>11)</sup>	= F-I-AFPE-1-4-1 Full coverage Integrated AFPE 1 monitored string per input port 4 input ports per channel (MPP1: 2, MPP2: 2) 1 monitored channel
AFPE (AFCI) classification in use with the option DC Connector Kit GEN24 (in accordance with IEC 63027) <sup>11)</sup>	= F-I-AFPE-2-2-1 Full coverage Integrated AFPE 2 monitored strings per input port 2 input ports per channel (MPP1: 1, MPP2: 1) 1 monitored channel

Data communication	
WiFi SMA-RP connection ( <b>FCC ID:</b> QKWPILOT01 / <b>IC ID:</b> 12270A-PILOT01)	802.11b/g/n (WPA, WPA2) Frequency: 2.4 GHz
Ethernet (LAN)	RJ45, 10/100 Mbit
Wired shutdown (WSD)	Max. 28 devices/WSD chain Max. distance between two devices = 100 m
Modbus RTU SunSpec (2x)	RS485 2-wire
Voltage level of digital inputs	Low: min. 0 V-max. 1.8 V High: min. 4.5 V-max. 28.8 V
Input currents of digital inputs	Depending on the input voltage; input resistance = 70 kOhm
Total power for digital output (internal supply)	6 W at 12 V (USB not connected)
Power per digital output (external supply)	1 A at >12.5 V-24 V (max. 3 A in total)
Datalogger/web server	Integrated

**Fronius Primo  
GEN24 5.0 SC /  
5.0 Plus SC**

DC input data	
MPP voltage range (at rated power)	190-480 V
Max. connected load ( $P_{PV\ max}$ )	
Total	7,500 Wp
PV 1	7,500 Wp
PV 2	7,500 Wp
Max. processable PV power	
Total	5,170 Wp
PV 1	5,170 Wp
PV 2	5,170 Wp

<b>DC input data</b>	
Max. input voltage at 1,000 W/m <sup>2</sup> /-10 °C in an open circuit	600 V
Min. input voltage	65 V
Feed-in start-up input voltage in grid operation <sup>5)</sup>	80 V
Max. input current PV 1 PV 2	22.0 A 16.0 A
Max. short circuit current for module array ( $I_{SC\ PV}$ ) PV 1 PV 2	44 A 32 A
Max. total short circuit current for module array ( $I_{SC\ PV1} + I_{SC\ PV2} = I_{SC\ max}$ )	76 A
Max. inverter backfeed current to the array <sup>3)</sup> PV 1 PV 2	44 A 32 A
Number of inputs—PV 1	2
Number of inputs—PV 2	2
Max. capacity of the PV generator against ground Total PV 1 PV 2	1,000 nF 1,000 nF 1,000 nF
Limit value of the insulation resistance test between module array and ground (on delivery) <sup>10)</sup>	100 k $\Omega$
Adjustable range of insulation resistance test between module array and ground <sup>9)</sup>	10-10,000 k $\Omega$
Limit value and trip time of sudden residual fault current monitoring (on delivery)	30 / 300 mA / ms 60 / 150 mA / ms 90 / 40 mA / ms
Limit value and trip time of continuous residual fault current monitoring (on delivery)	300 / 300 mA / ms
Adjustable range of continuous residual current monitoring <sup>9)</sup>	30-300 mA
Cyclic repetition of the insulation resistance test (on delivery)	24 h
Adjustable range for cyclic repetition of the insulation resistance test	-

<b>DC input data battery</b>	
Max. voltage	465 V

DC input data battery	
Min. voltage	150 V
Max. current	22 A
Max. output	5,000 W
DC inputs	1

AC input/output data	
Rated power ( $P_{nom}$ )	5,000 W
Max. output power	5,000 W
Rated apparent power	5,000 VA
Nominal mains voltage	1 ~ NPE 220 V / 230 V / 240 V
Min. mains voltage	155 V <sup>1)</sup>
Max. mains voltage	270 V <sup>1)</sup>
Max. output current	27.5 A
Current (inrush) <sup>6)</sup>	20 A / 1.3 ms
Nominal frequency	50 / 60 Hz <sup>1)</sup>
Initial symmetrical short-circuit current / phase $I_K''$	27.5 A
Nominal frequency for Full Backup	53 / 63 Hz <sup>1)</sup>
Total harmonic distortion	< 2%
Power factor $\cos \phi$ <sup>2)</sup>	0.8-1 (adjustable)
Max. permitted grid impedance $Z_{max}$ on PCC <sup>4)</sup>	None
Max. output fault current / duration	29 A / 3 ms

AC output data PV Point / PV Point Comfort	
Max. output power	4,133 W (for 5 s)
Rated power	3,000 W
Rated output current	13 A
Nominal mains voltage	1 ~ NPE 220 V / 230 V / 240 V
Nominal frequency	53 / 63 Hz <sup>1)</sup>
Switching time	~ 15 s
Power factor $\cos \phi$ <sup>2)</sup>	0-1

AC output data Full Backup	
Max. output power	6,890 W (for 5 s)
Rated power	5,000 W
Rated output current	21.7 A
Nominal mains voltage	1 ~ NPE 220 V / 230 V / 240 V
Nominal frequency for Full Backup	53 / 63 Hz <sup>1)</sup>

<b>AC output data Full Backup</b>	
Switching time	~ 10 s
Power factor cos phi <sup>2)</sup>	0-1

<b>General data</b>	
Max. efficiency	97.7%
Europ. efficiency (U <sub>mpp nom</sub> )	97.3%
Europ. efficiency (U <sub>mpp max</sub> )	96.9%
Europ. efficiency (U <sub>mpp min</sub> )	96.4%
Self-consumption at night	8.2 W
Cooling	Controlled forced-air ventilation
Protection class	IP 66
Dimensions H × W × D	530 × 474 × 165 millimeters
Weight	15.2 kg
Inverter topology	Non-insulated, no transformer
Permitted ambient temperature	-40 °C - +60 °C
Permissible humidity	0-100% (incl. condensation)
EMC emission class (in accordance with IEC 61000-6-2, IEC 61000-6-3)	B
DC / AC overvoltage category (in accordance with IEC 62109-1)	2 / 3
Pollution degree	2
Sound pressure level	42 dB(A) (ref. 20μPa)
Safety class (in accordance with IEC62103)	1

<b>Protection devices</b>	
DC isolation measurement <sup>11)</sup>	Warning/shutdown at R <sub>ISO</sub> < 100 kOhm
Overload performance	Operating point shift, power limit
DC disconnector	Integrated
RCMU <sup>11)</sup>	Integrated
RCMU classification	The software class of the safety platform(s) is defined as a class B control function (single-channel with periodic self-test) in accordance with IEC 60730 Annex H.
Active anti-islanding method	Frequency shift method
AFCI	Integrated

Protection devices	
AFPE (AFCI) classification (in accordance with IEC 63027) <sup>11)</sup>	= F-I-AFPE-1-4-1 Full coverage Integrated AFPE 1 monitored string per input port 4 input ports per channel (MPP1: 2, MPP2: 2) 1 monitored channel
AFPE (AFCI) classification in use with the option DC Connector Kit GEN24 (in accordance with IEC 63027) <sup>11)</sup>	= F-I-AFPE-2-2-1 Full coverage Integrated AFPE 2 monitored strings per input port 2 input ports per channel (MPP1: 1, MPP2: 1) 1 monitored channel

Data communication	
WiFi SMA-RP connection ( <b>FCC ID:</b> QKWPILOT01 / <b>IC ID:</b> 12270A-PILOT01)	802.11b/g/n (WPA, WPA2) Frequency: 2.4 GHz
Ethernet (LAN)	RJ45, 10/100 Mbit
Wired shutdown (WSD)	Max. 28 devices/WSD chain Max. distance between two devices = 100 m
Modbus RTU SunSpec (2x)	RS485 2-wire
Voltage level of digital inputs	Low: min. 0 V-max. 1.8 V High: min. 4.5 V-max. 28.8 V
Input currents of digital inputs	Depending on the input voltage; input resistance = 70 kOhm
Total power for digital output (internal supply)	6 W at 12 V (USB not connected)
Power per digital output (external supply)	1 A at >12.5 V-24 V (max. 3 A in total)
Datalogger/web server	Integrated

**Fronius Primo  
GEN24 6.0 SC /  
6.0 Plus SC**

DC input data	
MPP voltage range (at rated power)	190-480 V
Max. connected load ( $P_{PV \max}$ )	
Total	9,000 Wp
PV 1	8,000 Wp
PV 2	8,000 Wp
Max. processable PV power	
Total	6,200 Wp
PV 1	6,200 Wp
PV 2	6,200 Wp

<b>DC input data</b>	
Max. input voltage at 1,000 W/m <sup>2</sup> /-10 °C in an open circuit	600 V
Min. input voltage	65 V
Feed-in start-up input voltage in grid operation <sup>5)</sup>	80 V
Max. input current PV 1 PV 2	22.0 A 16.0 A
Max. short circuit current for module array ( $I_{SC\ PV}$ ) PV 1 PV 2	44 A 32 A
Max. total short circuit current for module array ( $I_{SC\ PV1} + I_{SC\ PV2} = I_{SC\ max}$ )	76 A
Max. inverter backfeed current to the array <sup>3)</sup> PV 1 PV 2	44 A 32 A
Number of inputs—PV 1	2
Number of inputs—PV 2	2
Max. capacity of the PV generator against ground Total PV 1 PV 2	1,200 nF 1,060 nF 1,060 nF
Limit value of the insulation resistance test between module array and ground (on delivery) <sup>10)</sup>	100 k $\Omega$
Adjustable range of insulation resistance test between module array and ground <sup>9)</sup>	10-10,000 k $\Omega$
Limit value and trip time of sudden residual fault current monitoring (on delivery)	30 / 300 mA / ms 60 / 150 mA / ms 90 / 40 mA / ms
Limit value and trip time of continuous residual fault current monitoring (on delivery)	300 / 300 mA / ms
Adjustable range of continuous residual current monitoring <sup>9)</sup>	30-300 mA
Cyclic repetition of the insulation resistance test (on delivery)	24 h
Adjustable range for cyclic repetition of the insulation resistance test	-

<b>DC input data battery</b>	
Max. voltage	465 V

DC input data battery	
Min. voltage	150 V
Max. current	22 A
Max. output	6,000 W
DC inputs	1

AC input/output data	
Rated power ( $P_{nom}$ )	6,000 W
Max. output power	6,000 W
Rated apparent power	6,000 VA
Nominal mains voltage	1 ~ NPE 220 V / 230 V / 240 V
Min. mains voltage	155 V <sup>1)</sup>
Max. mains voltage	270 V <sup>1)</sup>
Max. output current	27.5 A
Current (inrush) <sup>6)</sup>	20 A / 1.3 ms
Nominal frequency	50 / 60 Hz <sup>1)</sup>
Initial symmetrical short-circuit current / phase $I_K''$	27.5 A
Nominal frequency for Full Backup	53 / 63 Hz <sup>1)</sup>
Total harmonic distortion	< 2%
Power factor $\cos \phi$ <sup>2)</sup>	0.8-1 (adjustable)
Max. permitted grid impedance $Z_{max}$ on PCC <sup>4)</sup>	None
Max. output fault current / duration	29 A / 3 ms

AC output data PV Point / PV Point Comfort	
Max. output power	4,133 W (for 5 s)
Rated power	3,000 W
Rated output current	13 A
Nominal mains voltage	1 ~ NPE 220 V / 230 V / 240 V
Nominal frequency	53 / 63 Hz <sup>1)</sup>
Switching time	~ 15 s
Power factor $\cos \phi$ <sup>2)</sup>	0-1

AC output data Full Backup	
Max. output power	8,268 W (for 5 s)
Rated power	6,000 W
Rated output current	26.1 A
Nominal mains voltage	1 ~ NPE 220 V / 230 V / 240 V
Nominal frequency for Full Backup	53 / 63 Hz <sup>1)</sup>

<b>AC output data Full Backup</b>	
Switching time	~ 10 s
Power factor cos phi <sup>2)</sup>	0-1

<b>General data</b>	
Max. efficiency	97.7%
Europ. efficiency (U <sub>mpp nom</sub> )	97.4%
Europ. efficiency (U <sub>mpp max</sub> )	97.1%
Europ. efficiency (U <sub>mpp min</sub> )	96.5%
Self-consumption at night	8.2 W
Cooling	Controlled forced-air ventilation
Protection class	IP 66
Dimensions H × W × D	530 × 474 × 165 millimeters
Weight	15.2 kg
Inverter topology	Non-insulated, no transformer
Permitted ambient temperature	-40 °C - +60 °C
Permissible humidity	0-100% (incl. condensation)
EMC emission class (in accordance with IEC 61000-6-2, IEC 61000-6-3)	B
DC / AC overvoltage category (in accordance with IEC 62109-1)	2 / 3
Pollution degree	2
Sound pressure level	42 dB(A) (ref. 20μPa)
Safety class (in accordance with IEC62103)	1

<b>Protection devices</b>	
DC isolation measurement <sup>11)</sup>	Warning/shutdown at R <sub>ISO</sub> < 100 kOhm
Overload performance	Operating point shift, power limit
DC disconnector	Integrated
RCMU <sup>11)</sup>	Integrated
RCMU classification	The software class of the safety platform(s) is defined as a class B control function (single-channel with periodic self-test) in accordance with IEC 60730 Annex H.
Active anti-islanding method	Frequency shift method
AFCI	Integrated

Protection devices	
AFPE (AFCI) classification (in accordance with IEC 63027) <sup>11)</sup>	= F-I-AFPE-1-4-1 Full coverage Integrated AFPE 1 monitored string per input port 4 input ports per channel (MPP1: 2, MPP2: 2) 1 monitored channel
AFPE (AFCI) classification in use with the option DC Connector Kit GEN24 (in accordance with IEC 63027) <sup>11)</sup>	= F-I-AFPE-2-2-1 Full coverage Integrated AFPE 2 monitored strings per input port 2 input ports per channel (MPP1: 1, MPP2: 1) 1 monitored channel

Data communication	
WiFi SMA-RP connection ( <b>FCC ID:</b> QKWPILOT01 / <b>IC ID:</b> 12270A-PILOT01)	802.11b/g/n (WPA, WPA2) Frequency: 2.4 GHz
Ethernet (LAN)	RJ45, 10/100 Mbit
Wired shutdown (WSD)	Max. 28 devices/WSD chain Max. distance between two devices = 100 m
Modbus RTU SunSpec (2x)	RS485 2-wire
Voltage level of digital inputs	Low: min. 0 V-max. 1.8 V High: min. 4.5 V-max. 28.8 V
Input currents of digital inputs	Depending on the input voltage; input resistance = 70 kOhm
Total power for digital output (internal supply)	6 W at 12 V (USB not connected)
Power per digital output (external supply)	1 A at >12.5 V-24 V (max. 3 A in total)
Datalogger/web server	Integrated

## WLAN

Frequency range	2412 - 2462 MHz
Channels / power used	Channel: 1-11 b,g,n HT20 Channel: 3-9 HT40 <18 dBm
Modulation	802.11b: DSSS (1Mbps DBPSK, 2Mbps DQPSK, 5.5/11Mbps CCK) 802.11g: OFDM (6/9Mbps BPSK, 12/18Mbps QPSK, 24/36Mbps 16-QAM, 48/54Mbps 64-QAM) 802.11n: OFDM (6.5 BPSK, QPSK, 16-QAM, 64-QAM)

**Technical data of surge protection device DC SPD type 1+2 GEN24**

<b>General data</b>	
Continuous operating current ( $I_{cpv}$ )	< 0.1 mA
Rated discharge current ( $I_n$ ) - 15 x 8/20 $\mu$ s pulses	20 kA
Lightning surge current ( $I_{imp}$ ) Max. discharge capacity @ 10/350 $\mu$ s	6.25 kA
Protection level ( $U_p$ ) (star-shaped mounting)	4 kV
Short circuit strength PV ( $I_{scpv}$ )	15 kA

<b>Disconnecter</b>	
Thermal disconnecter	Integrated
External fuse	None

<b>Mechanical properties</b>	
Disconnection indicator	Mechanical indicator (red)
Remote communication of the connection interruption	Output on the changeover contact
Housing material	Thermoplastic UL-94-V0
Test standards	IEC 61643-31 / DIN EN 50539-11 UL1449 ed.4 / VDE 0185-305-3 Bbl. 5

**Explanation of footnotes**

- 1) The values provided are standard values. If required, the inverter is customized for a specific country.
- 2) Depending on the country setup or device-specific settings (ind. = inductive; cap. = capacitive).
- 3) Maximum current from a defective PV module to all other PV modules. From the inverter itself to the PV side of the inverter, this is 0 A.
- 4) Assured by the electrical design of the inverter.
- 5) For backup power mode (PV Point) without battery, a min. voltage of 150 V is required.
- 6) Peak current when turning on the inverter.
- 7) The total nominal output power per phase must not exceed the nominal output power of the inverter.
- 8) Valid for Fronius Primo GEN24 with battery connection and Fronius Primo GEN24 Plus.
- 9) The values provided are standard values. These values must be adjusted according to requirements and PV output.
- 10) The value provided is a max. value. If this value is exceeded, this may impair the function.
- 11) Software class B (single-channel with periodic self-test) according to IEC 60730-1 Appendix H.

**Integrated DC  
disconnector**

<b>General data</b>	
Product name	Benedict LSA32 E 8229
Rated insulation voltage	1000 V <sub>DC</sub>
Rated impulse withstand voltage	6 kV
Suitability for insulation	Yes, DC only
Utilization category and/or PV utilization category	according to IEC/EN 60947-3 utilization category DC-PV2
Rated short-time withstand current (I <sub>cw</sub> )	Rated short-time withstand current (I <sub>cw</sub> ): 1000 A
Rated short-circuit capacity (I <sub>cm</sub> )	Rated short-circuit capacity (I <sub>cm</sub> ): 1000 A

<b>Rated operating current and rated breaking capacity</b>				
Rated operating voltage (U <sub>e</sub> )	Rated operating current (I <sub>e</sub> )	I <sub>(make)</sub> / I <sub>(break)</sub>	Rated operating current (I <sub>e</sub> )	I <sub>(make)</sub> / I <sub>(break)</sub>
300 V <sub>DC</sub>	27 A	108 A	47 A	188 A
400 V <sub>DC</sub>	20 A	80 A	45 A	180 A
500 V <sub>DC</sub>	14 A	56 A	38 A	152 A
600 V <sub>DC</sub>	11.5 A	46 A	33 A	132 A
700 V <sub>DC</sub>	7.5 A	30 A	28 A	112 A
800 V <sub>DC</sub>	5.75 A	23 A	23 A	92 A
900 V <sub>DC</sub>	4.75 A	19 A	20 A	80 A
1 000 V <sub>DC</sub>	4 A	16 A	13 A	52 A
Number of pins	1	1	2	2

# **System circuit diagrams**

# Fronius Primo GEN24 and Fronius Reserva

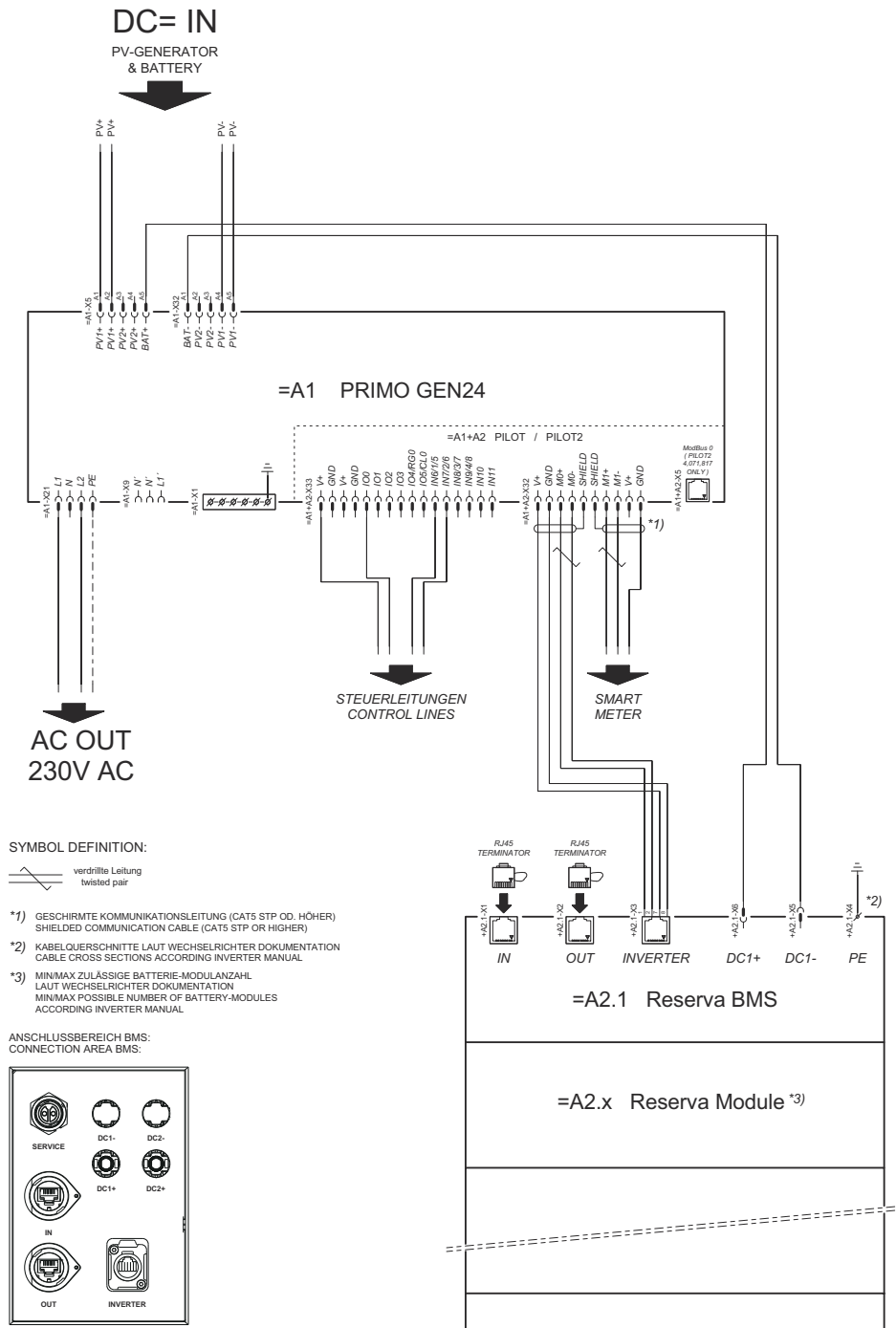

# Fronius Primo GEN24 with Fronius Reserva connected in parallel

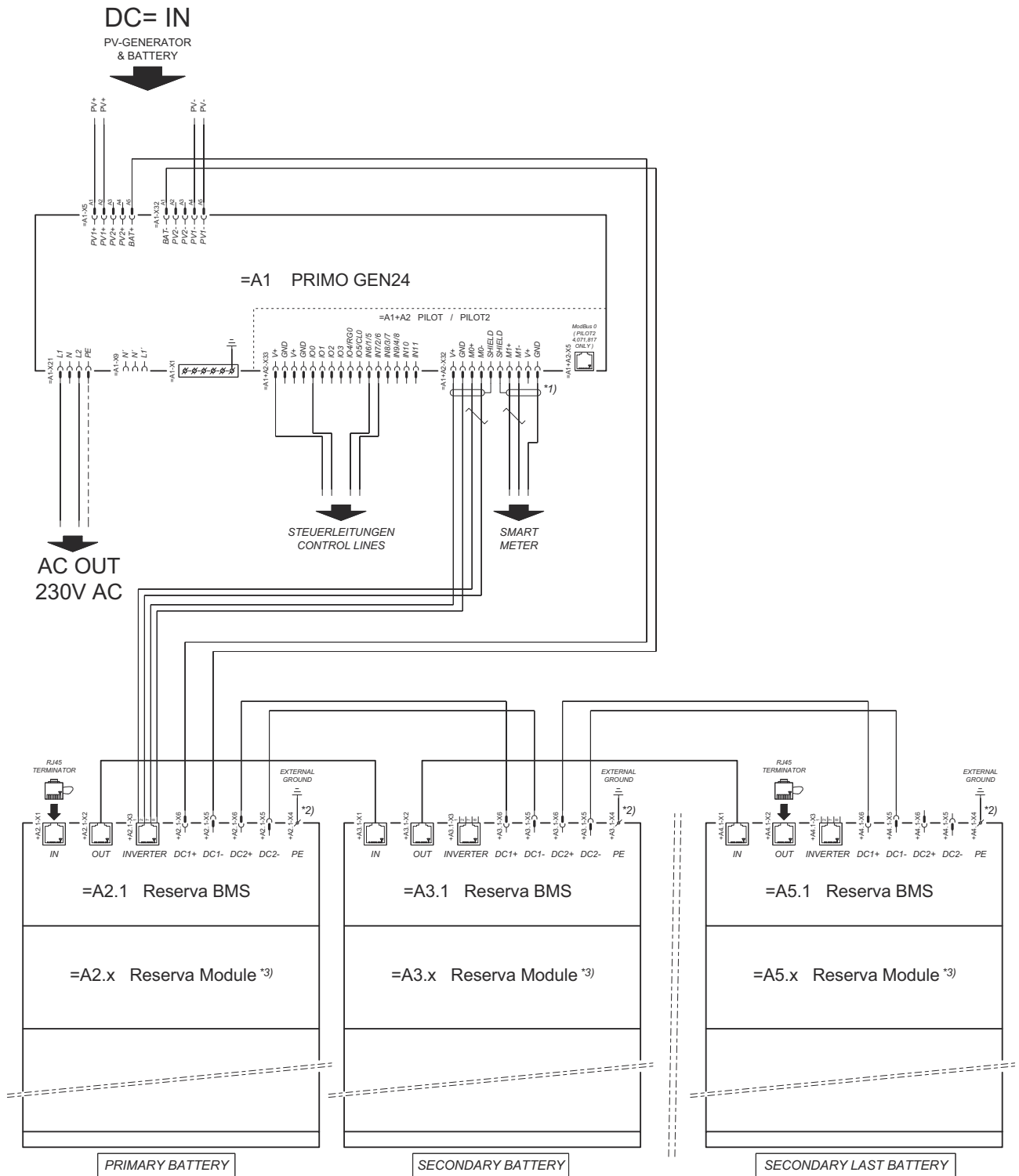

**SYMBOL DEFINITION:**

verdrehte Leitung  
twisted pair

\*1) GESCHIRMTE KOMMUNIKATIONSLEITUNG (CAT5 STP OD. HÖHER)  
SHIELDED COMMUNICATION CABLE (CAT5 STP OR HIGHER)

\*2) KABELÜRSCHNITTE LAUT WECHSELRICHTER DOKUMENTATION  
CABLE CROSS SECTIONS ACCORDING INVERTER MANUAL

\*3) MIN/MAX ZULÄSSIGE BATTERIE-MODULANZAHL  
LAUT WECHSELRICHTER DOKUMENTATION  
MIN/MAX POSSIBLE NUMBER OF BATTERY-MODULES  
ACCORDING INVERTER MANUAL

**ANSCHLUSSBEREICH BMS:  
CONNECTION AREA BMS:**

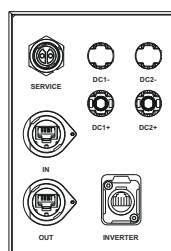

# Fronius Primo GEN24 and Fronius Reserva Pro

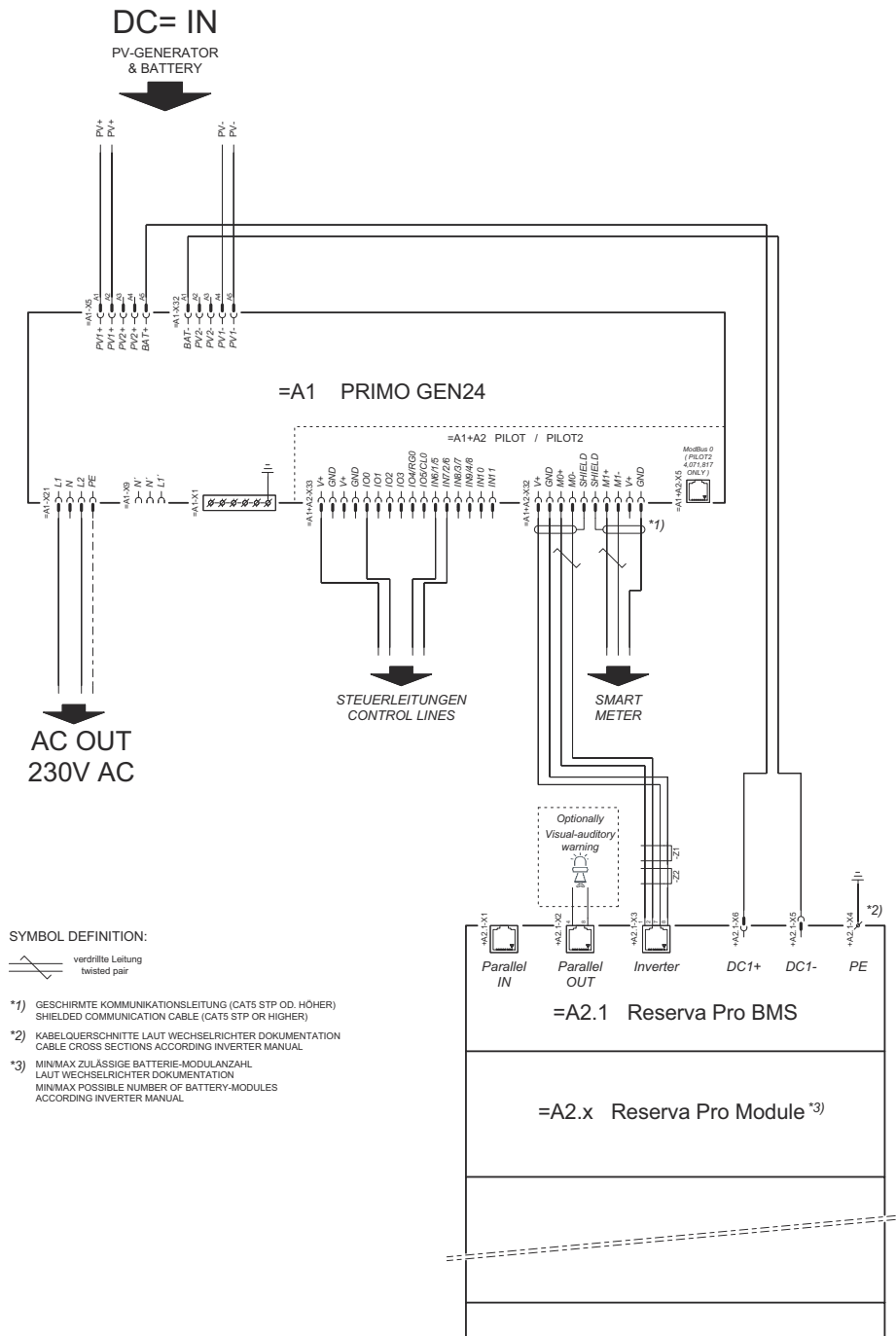

# Fronius Primo GEN24 with Fronius Reserva Pro connected in parallel

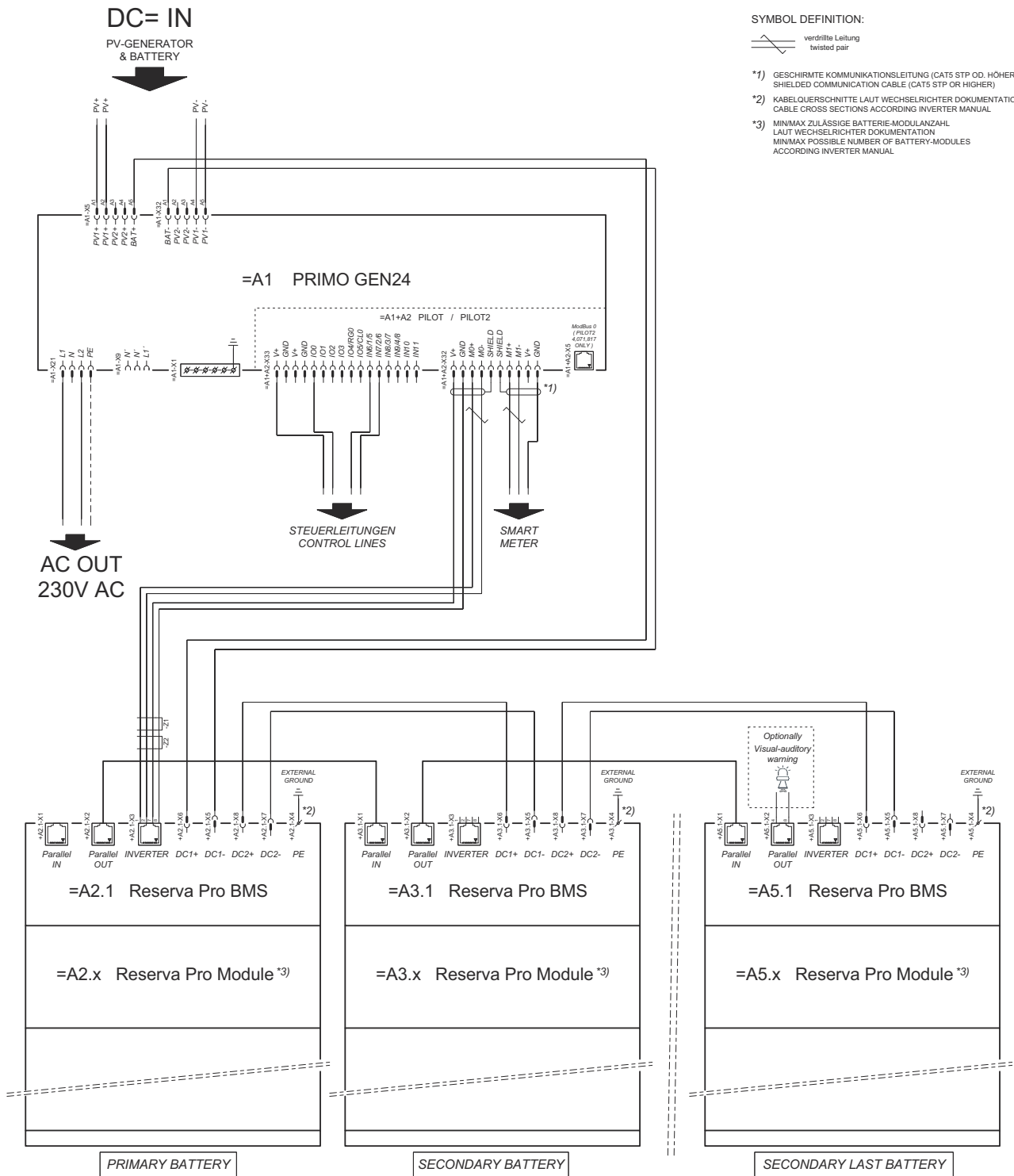

# Fronius Primo GEN24 and BYD Battery-Box Premium HV

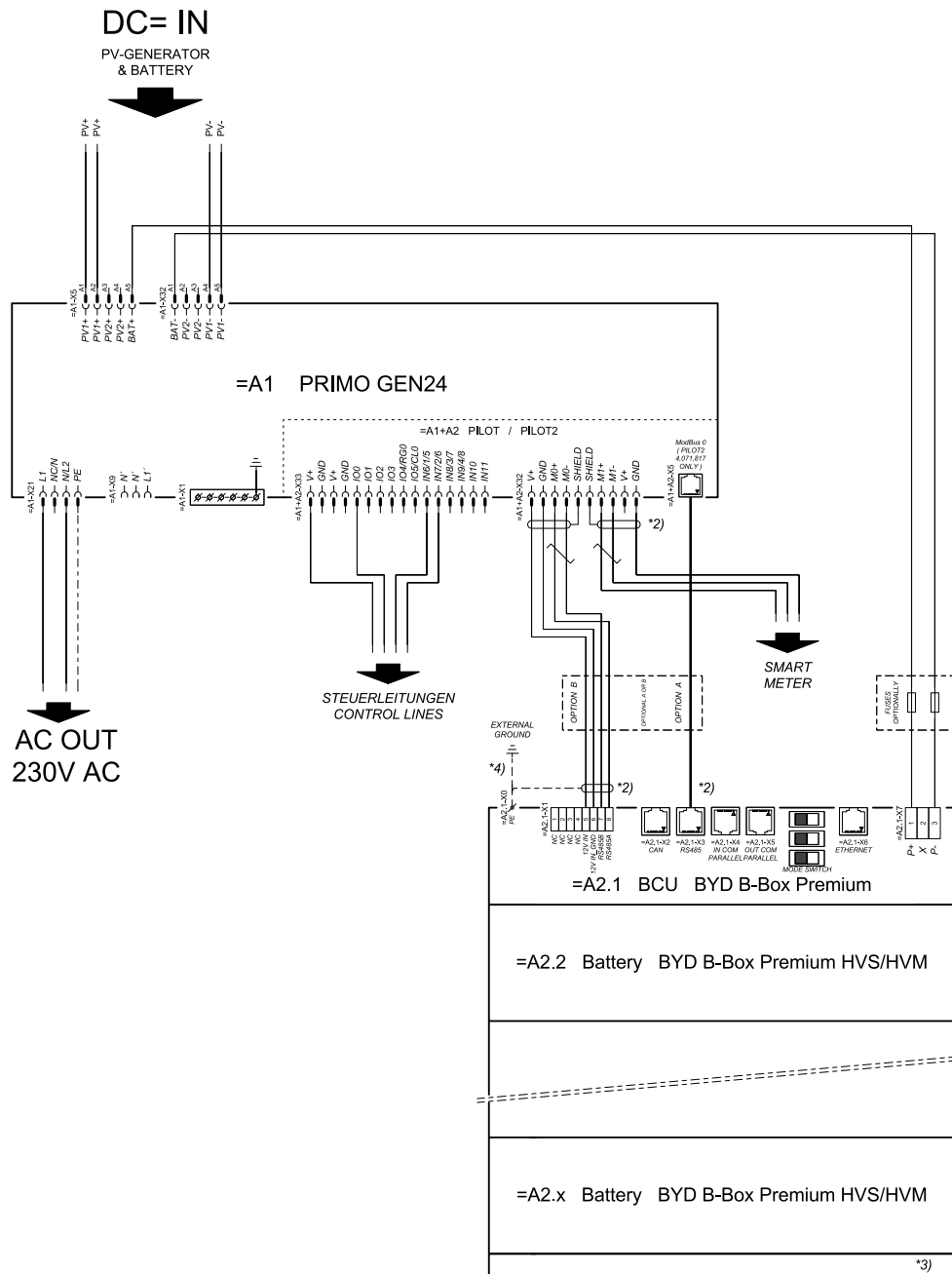

### connection area at BCU:

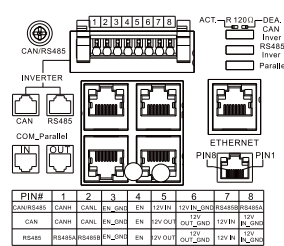

### SYMBOL DEFINITION:

VERDRILLTE LEITUNG  
TWISTED PAIR

\*2) DER MODBUS-KOMMUNIKATIONS-BUS ERFORDERT DEN ABSCHLUSS DER LEITUNGSSENDEN MITTELS ABSCHLUSSWIDERSTÄNDE. DETAILS SIEHE WECHSELRICHTER-DOKUMENTATION. THE MODBUS COMMUNICATION BUS REQUIRES THE TERMINATION OF CABLE ENDS WITH TERMINATION RESISTORS. DETAILS ACCORDING INVERTER MANUAL.

\*3) MIN/MAX ZULÄSSIGE MODULANZAHL LAUT WECHSELRICHTER-DOKUMENTATION. MIN/MAX POSSIBLE NUMBER OF MODULES ACCORDING INVERTER MANUAL.

\*4) DEN QUERSCHNITT DER ERDGUNGSLEITUNG AUS DER DOKUMENTATION DER BYD BATTERY-BOX PREMIUM ENTNEHMEN (> 10 MM²). REFER PE CABLE CROSS-SECTION ACCORDING TO BYD BATTERY-BOX PREMIUM MANUAL (> 10 MM² / AWG7)

# Fronius Primo GEN24 with two BYD Battery-Box Premium HV connected in parallel

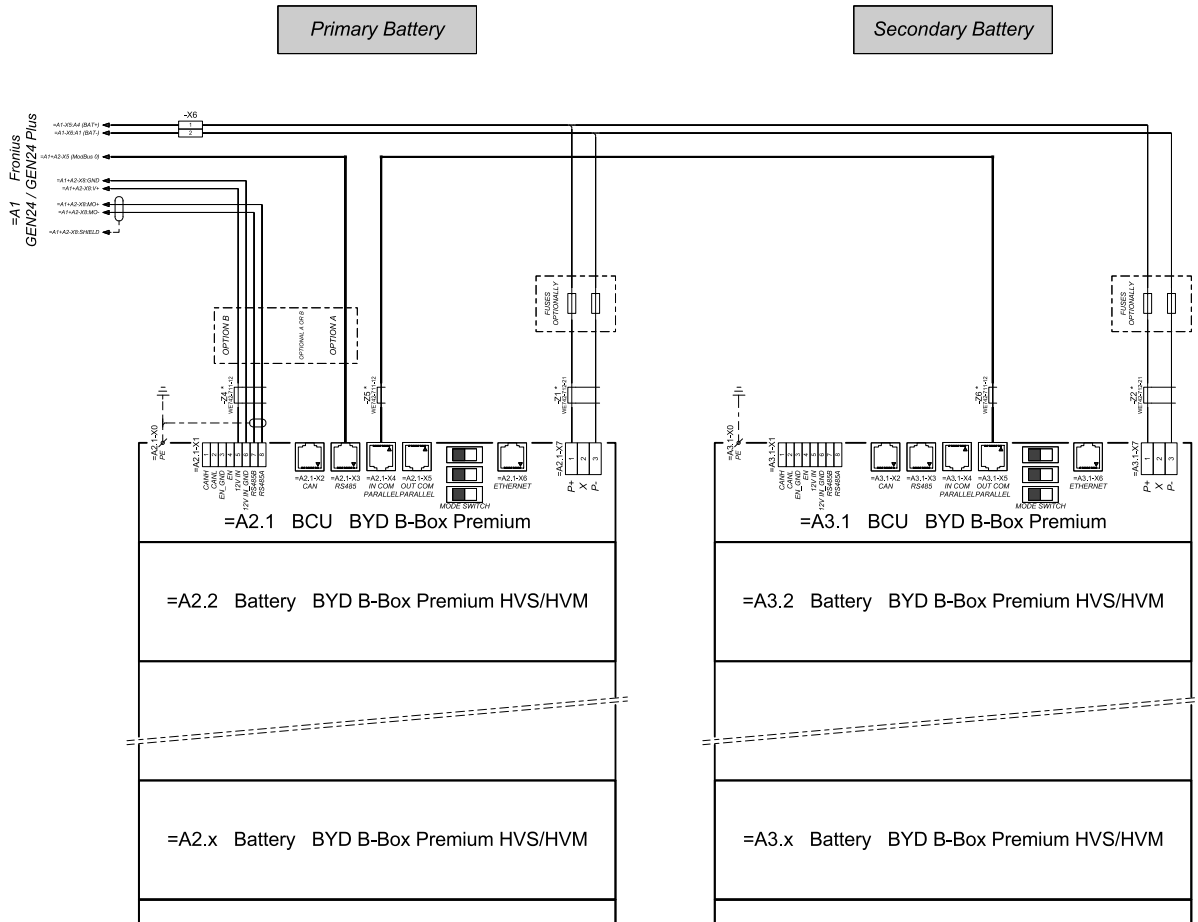

connection area at BCU's:

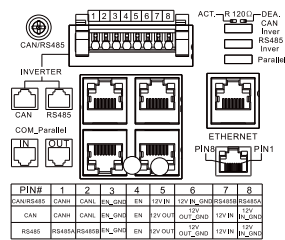

The ferrite cores -Z1 to -Z6 are only mandatory for storage installations in Italy!  
 Certified ferrites for DC connection path: -Z1 and -Z2: WE742-712-21, manufacturer: Würth  
 Certified ferrites for communication connection: -Z4 to -Z6: WE742-711-12, manufacturer: Würth

# Fronius Primo GEN24 with three BYD Battery-Box Premium HV connected in parallel

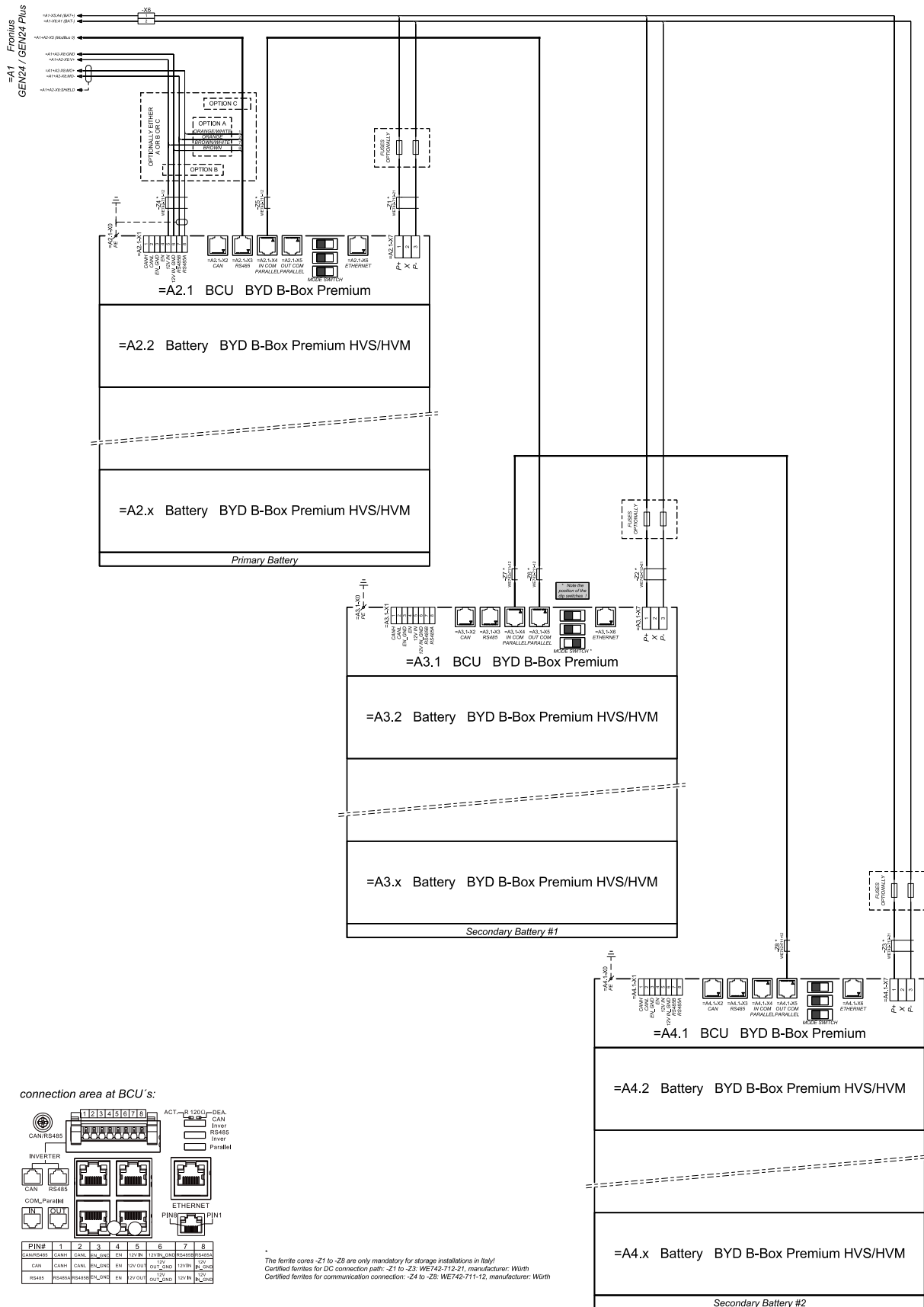



# Fronius Primo GEN24 with BYD Battery-Box HVS +/-HVM+ connected in parallel

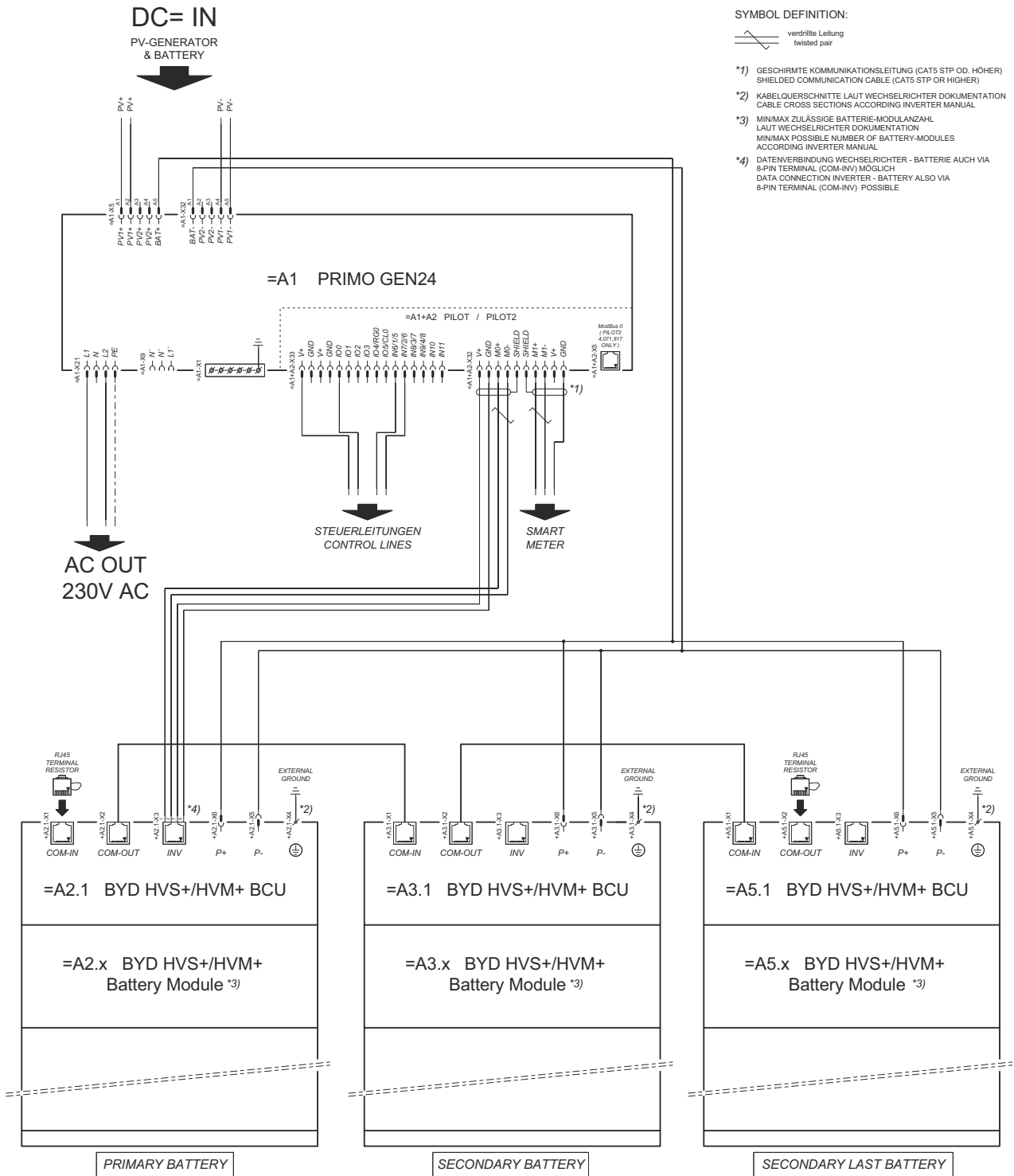

# Fronius Primo GEN24 and LG FLEX

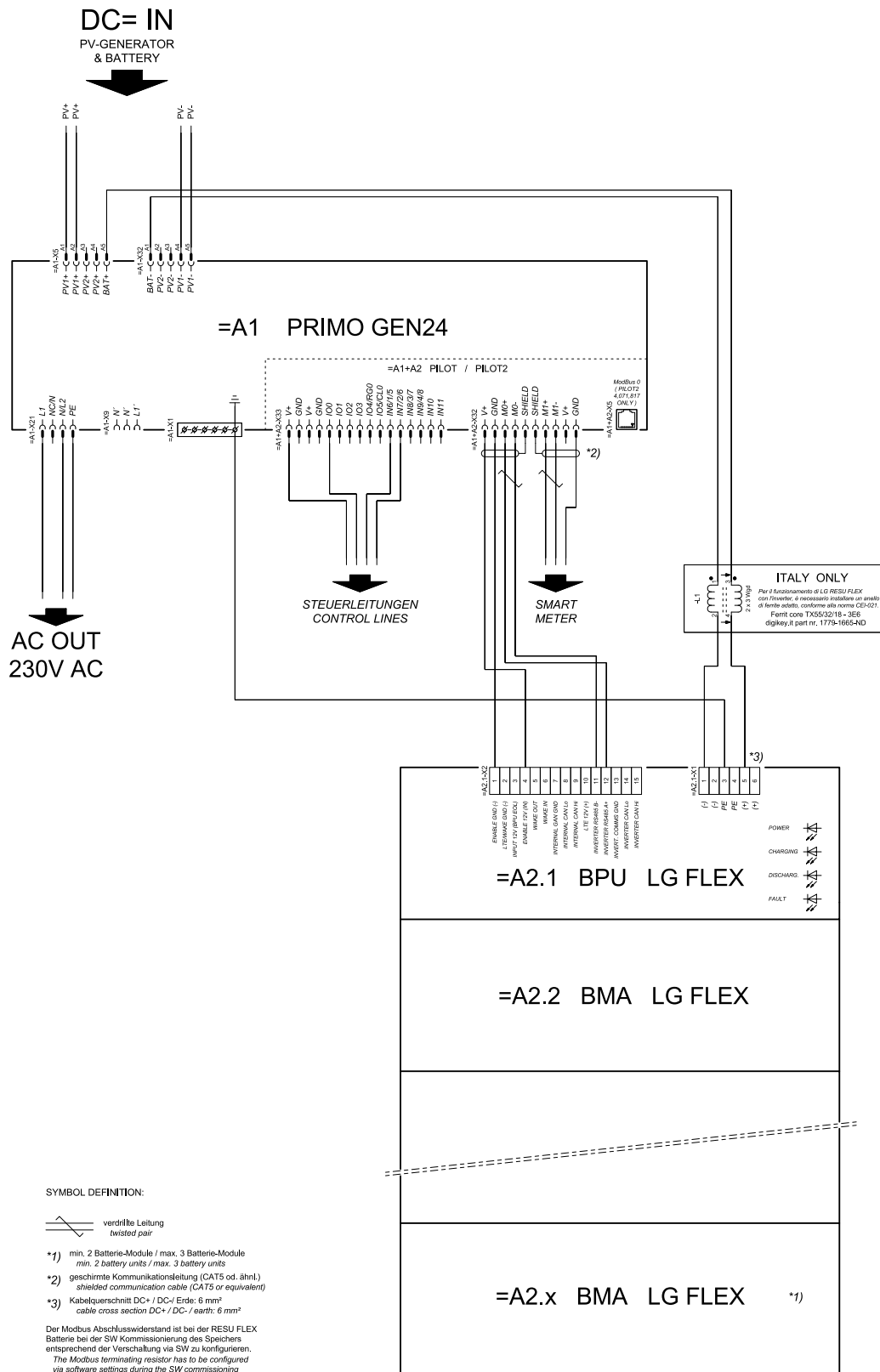

# Surge protection device (SPD)

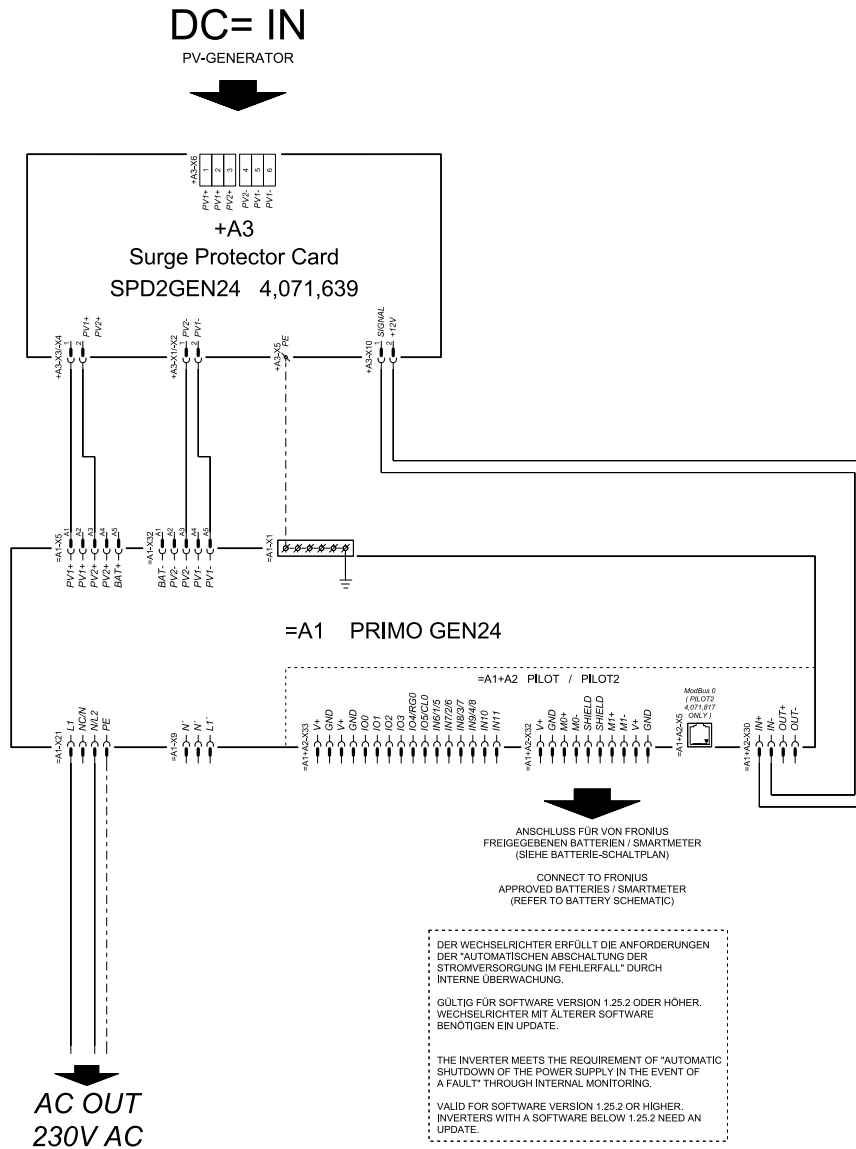

# **Circuit diagrams—PV Point**

# Emergency power terminal—PV Point (OP)

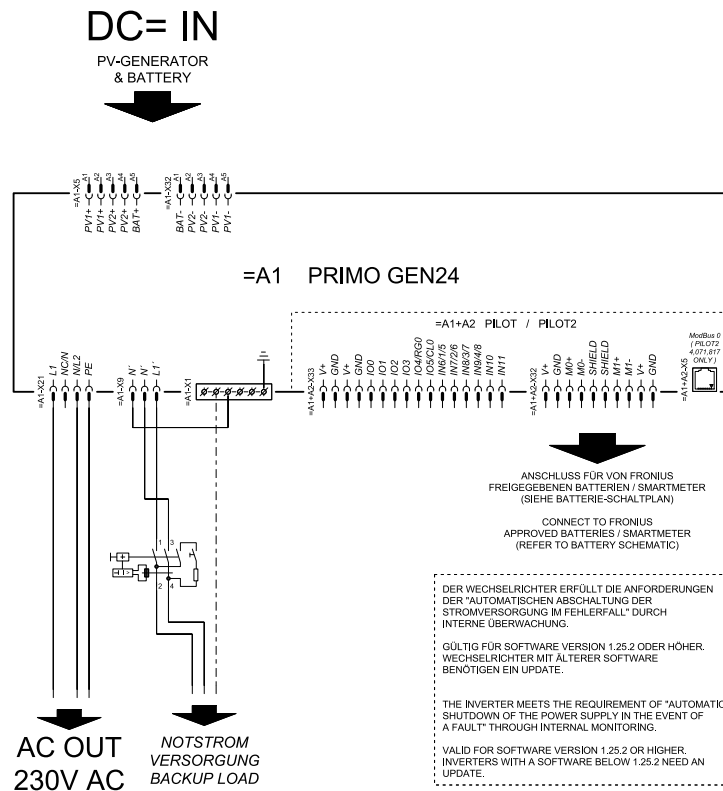

# Circuit diagram - PV Point (OP) Australia

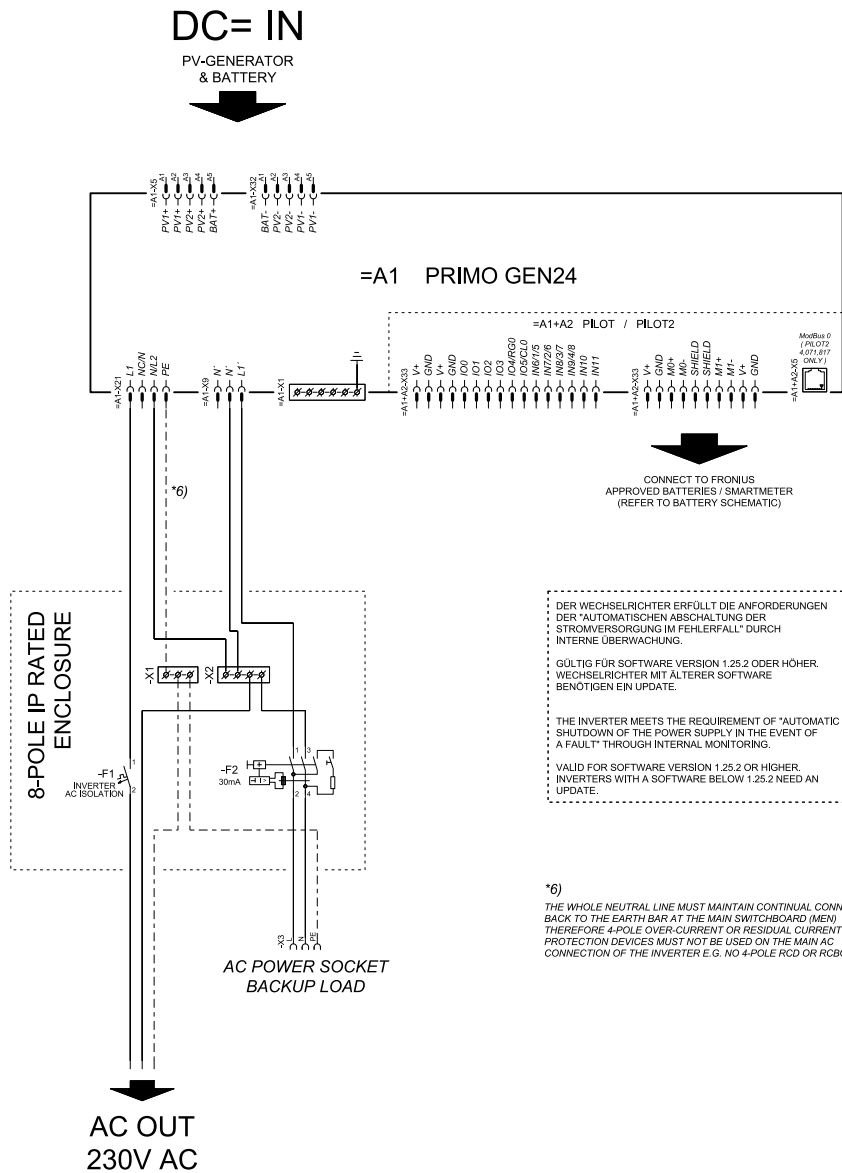

# Backup power terminal - PV Point (OP) with battery only for France

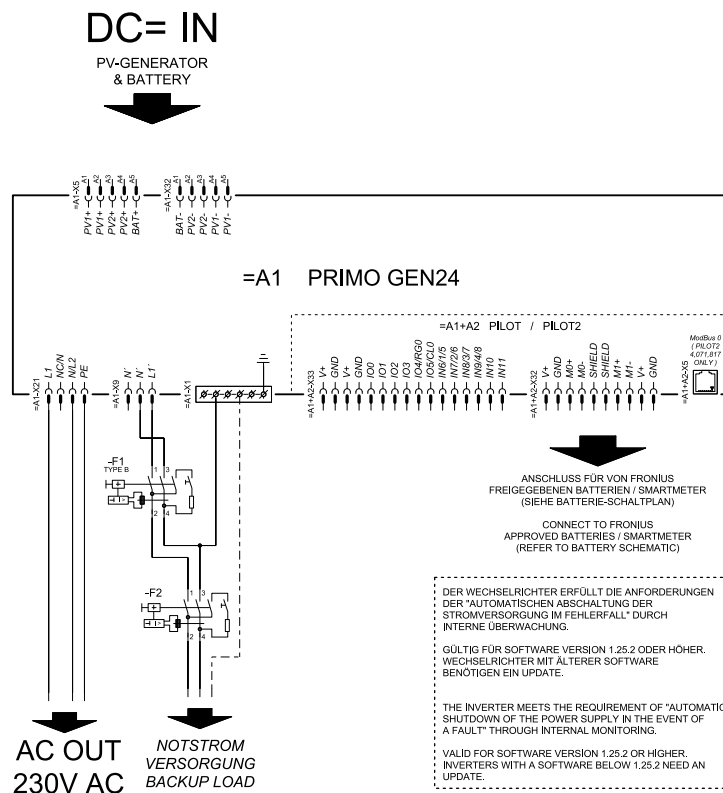

# Backup power terminal - PV Point (OP) manual changeover

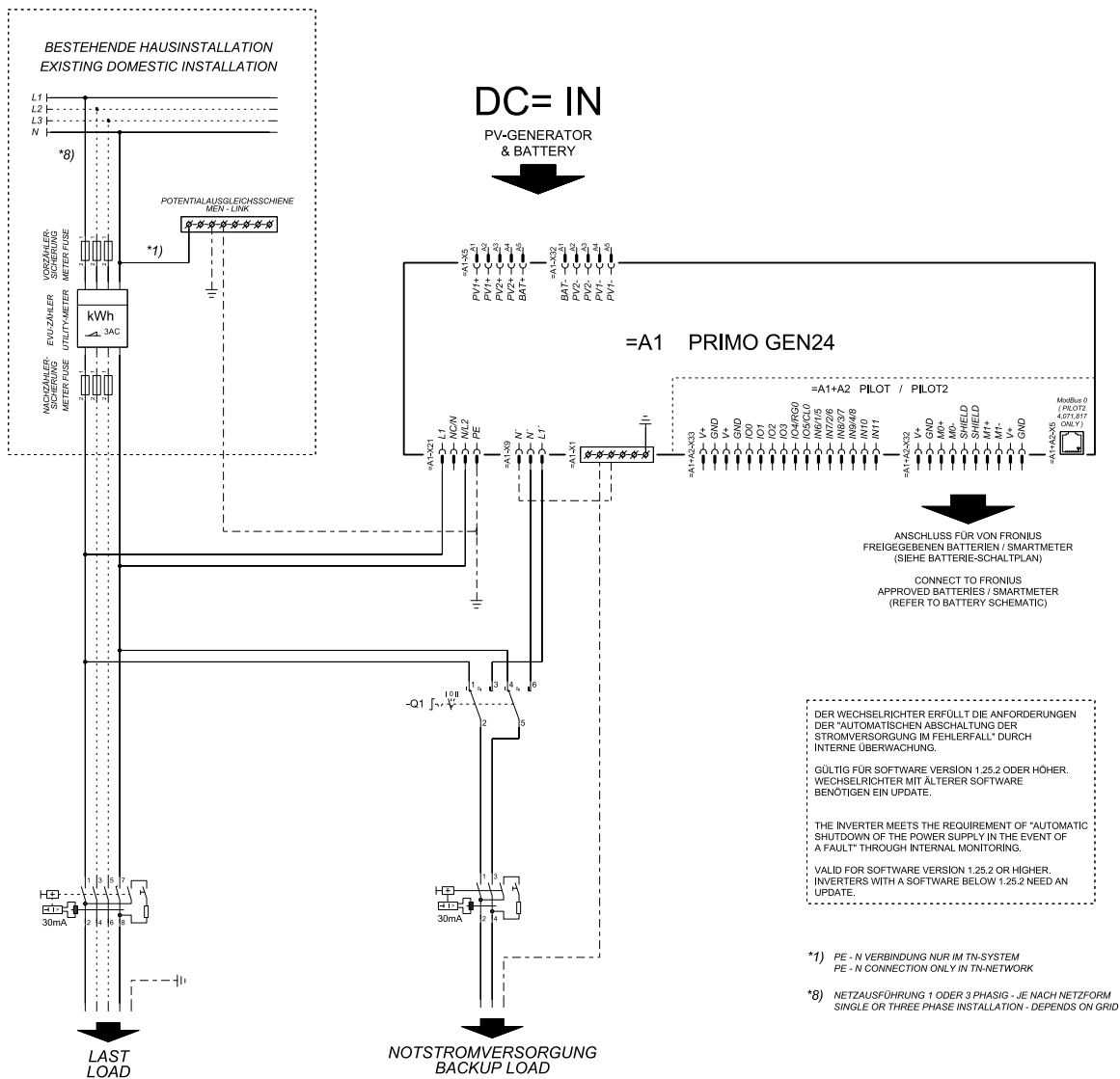

# PV Point Comfort

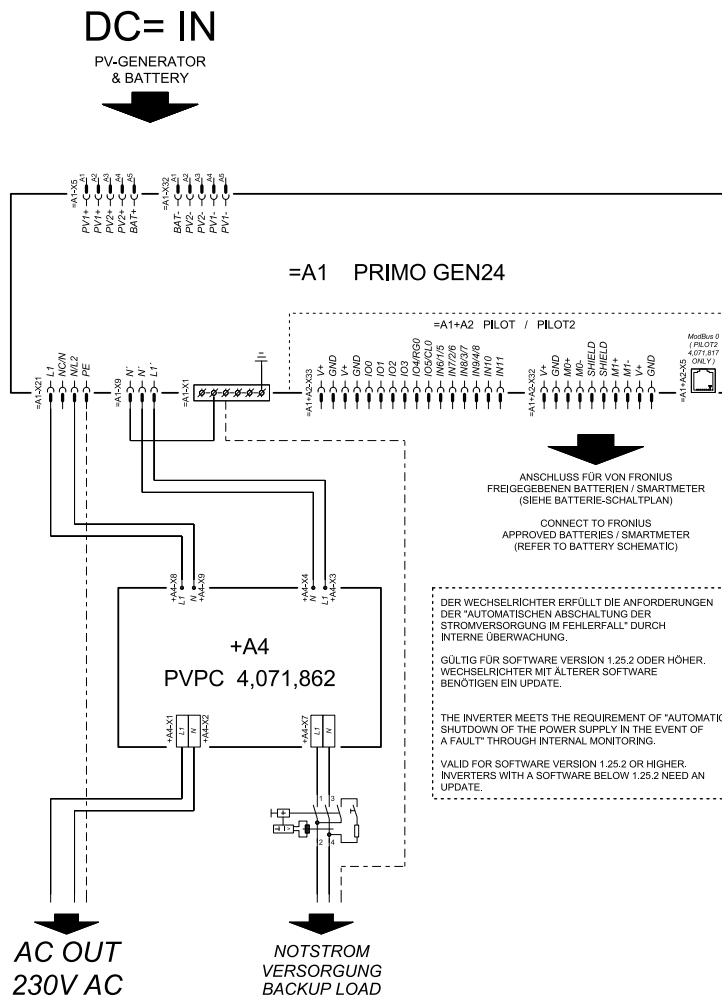

# **Circuit diagrams—automatic switch to backup power with Fronius Backup Controller**







# **Circuit diagrams—automatic switch to backup power with third-party components**

# Automatic switch to backup power 1-pin single FRT-capable separation

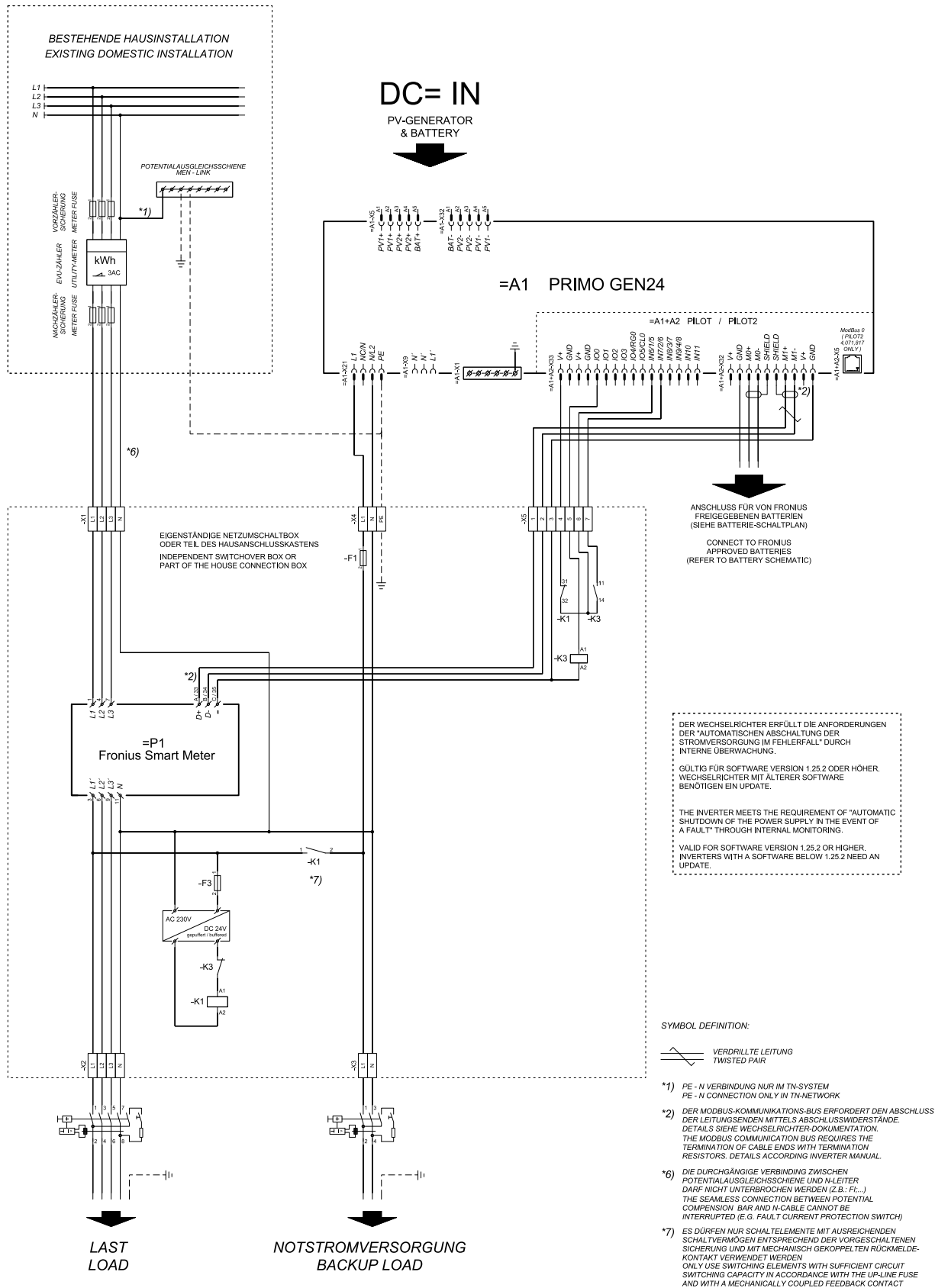

# Automatic switch to backup power 1-pin single separation - e.g., Australia

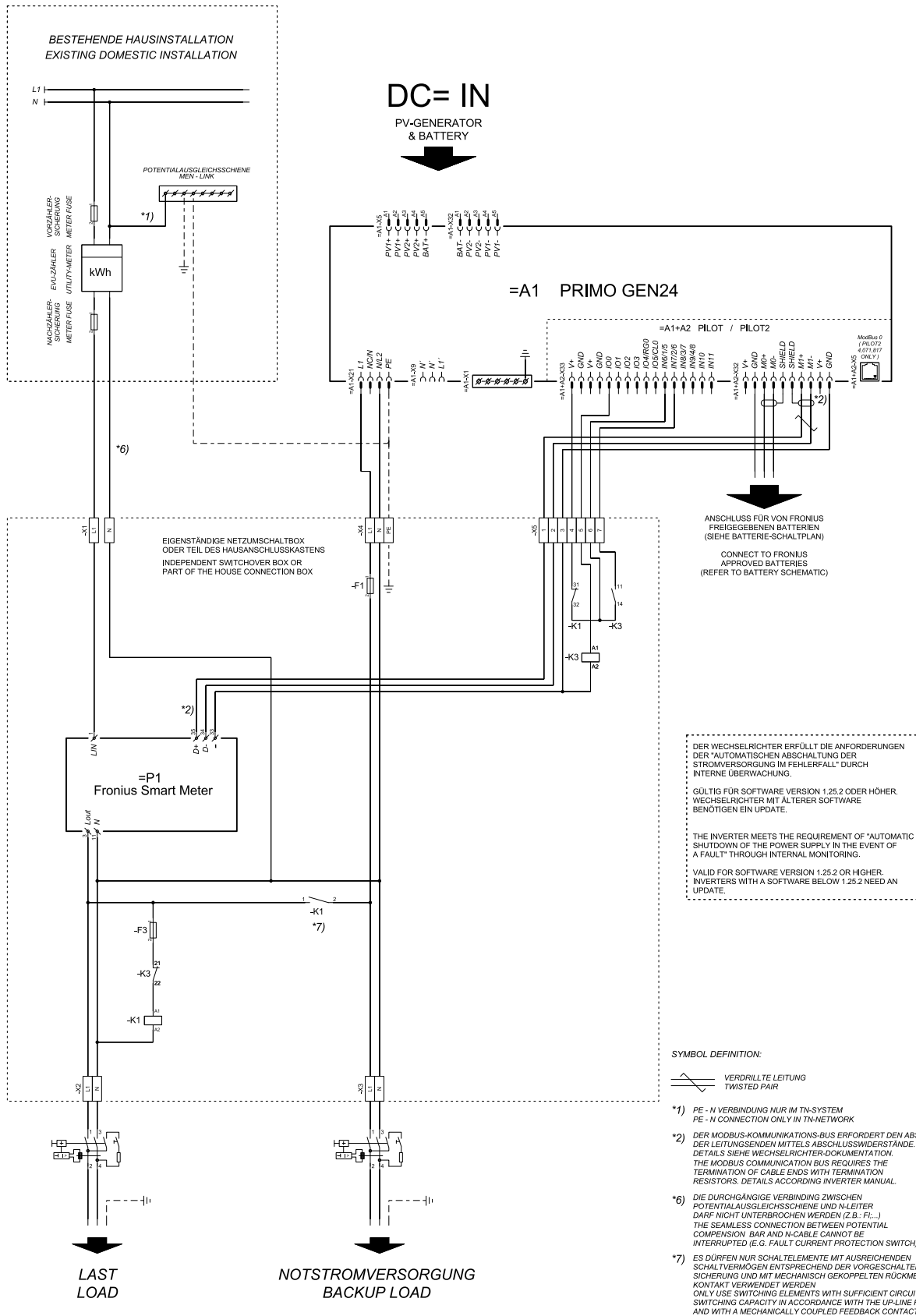

# Automatic switch to backup power 2-pin single separation - e.g., Germany

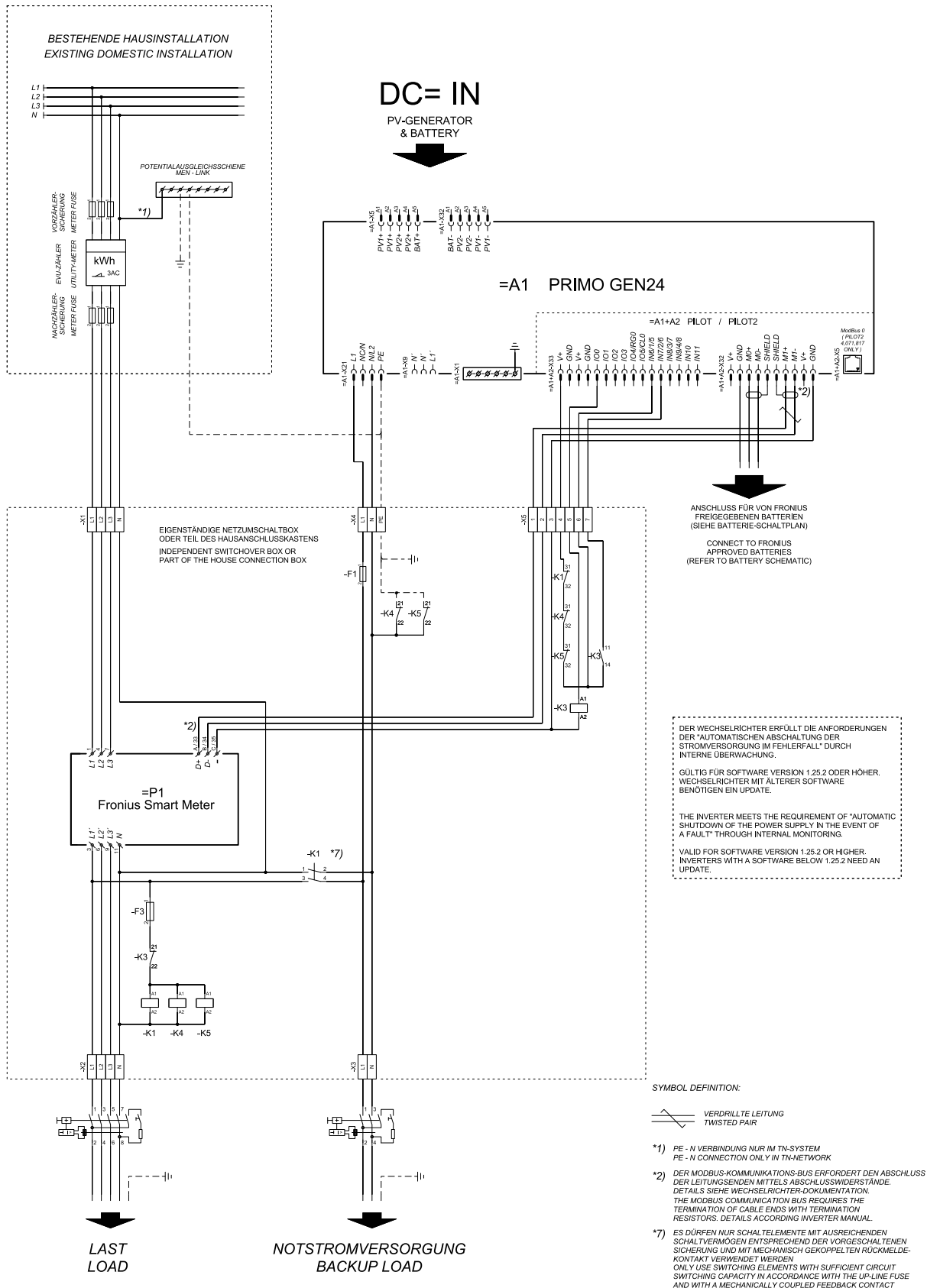

# Automatic switch to backup power 2-pin single separation - e.g., France

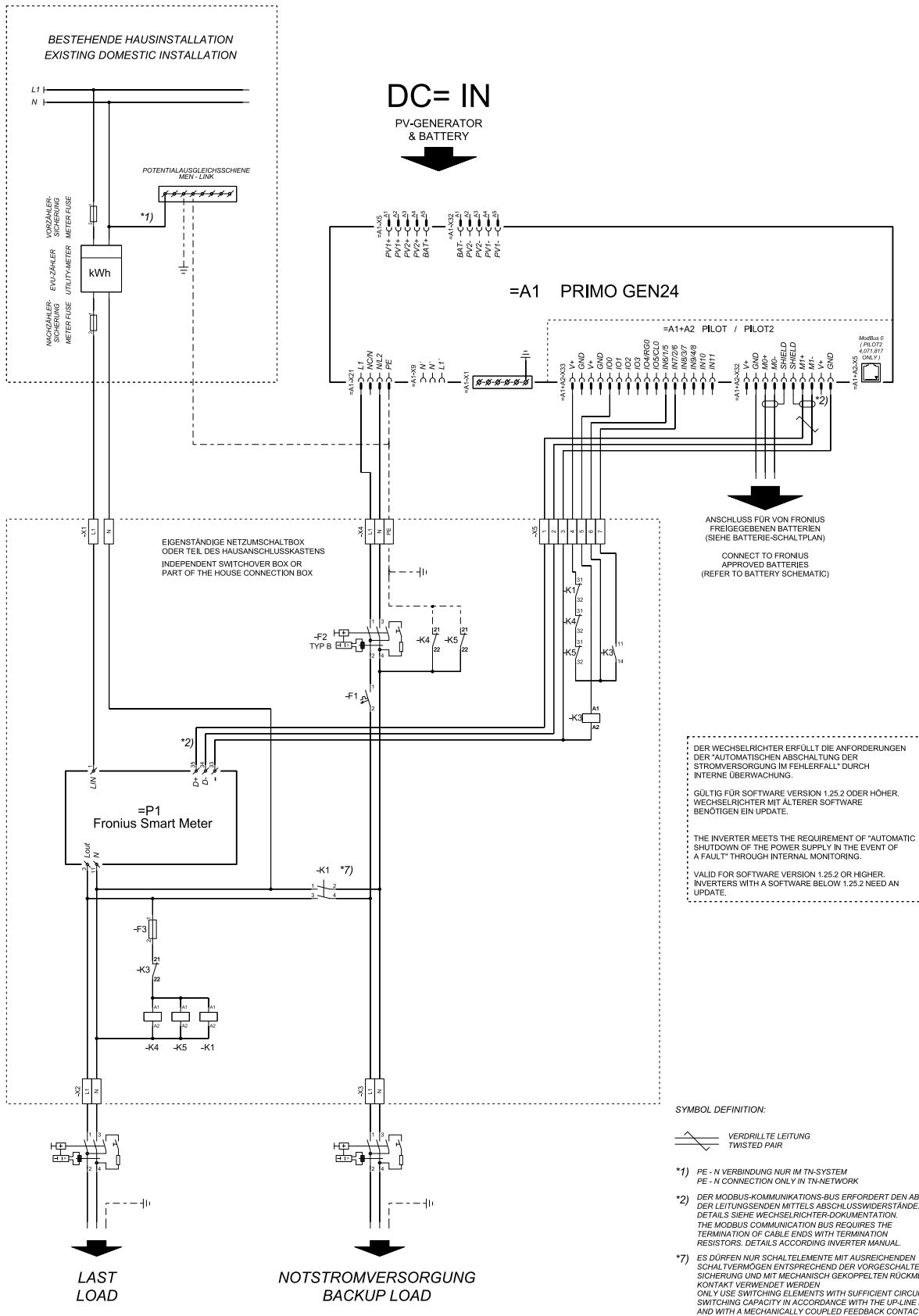

# Automatic switch to backup power 2-pin single separation - e.g., UK

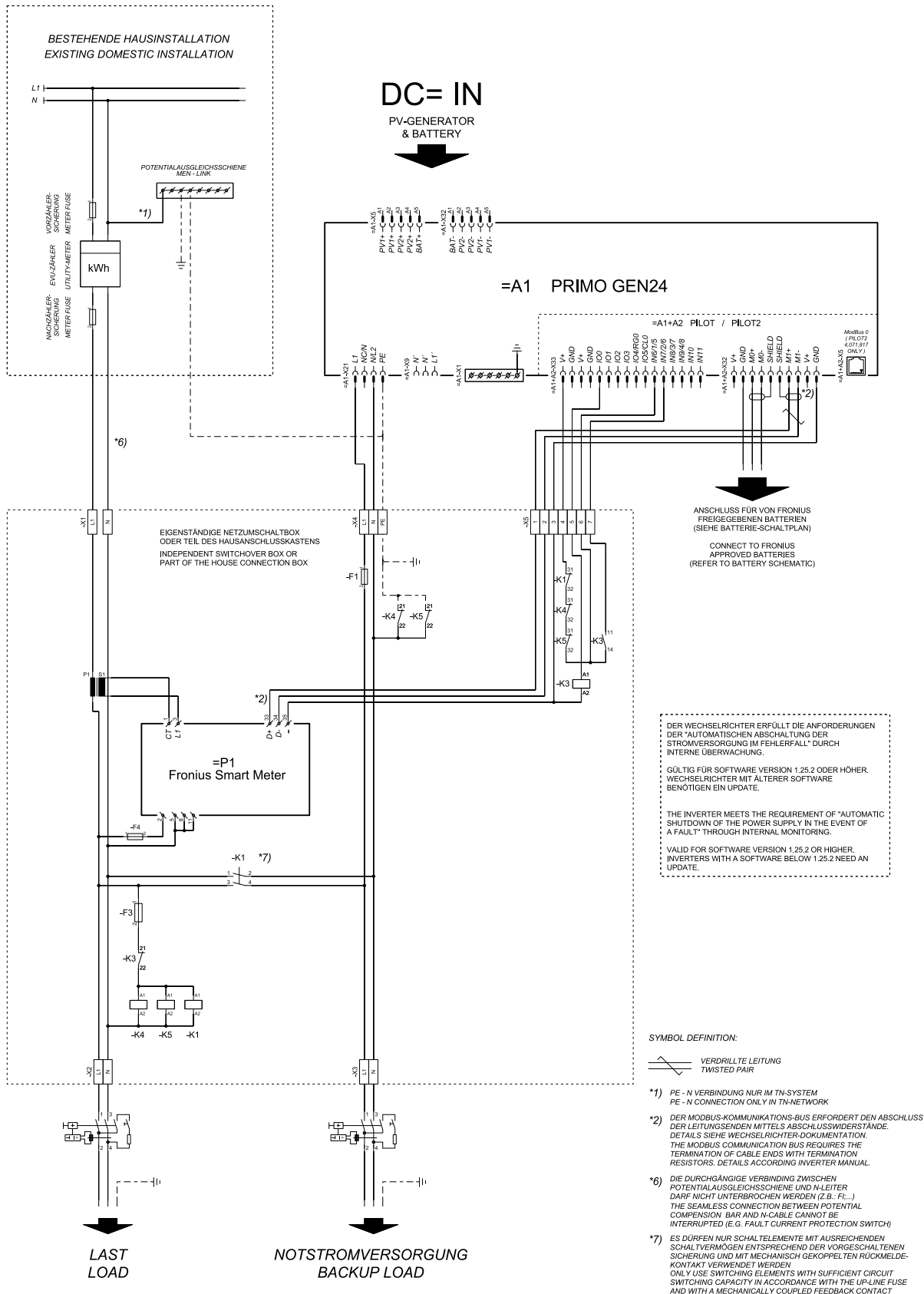

# Automatic switch to backup power 2-pin single separation - e.g., Spain

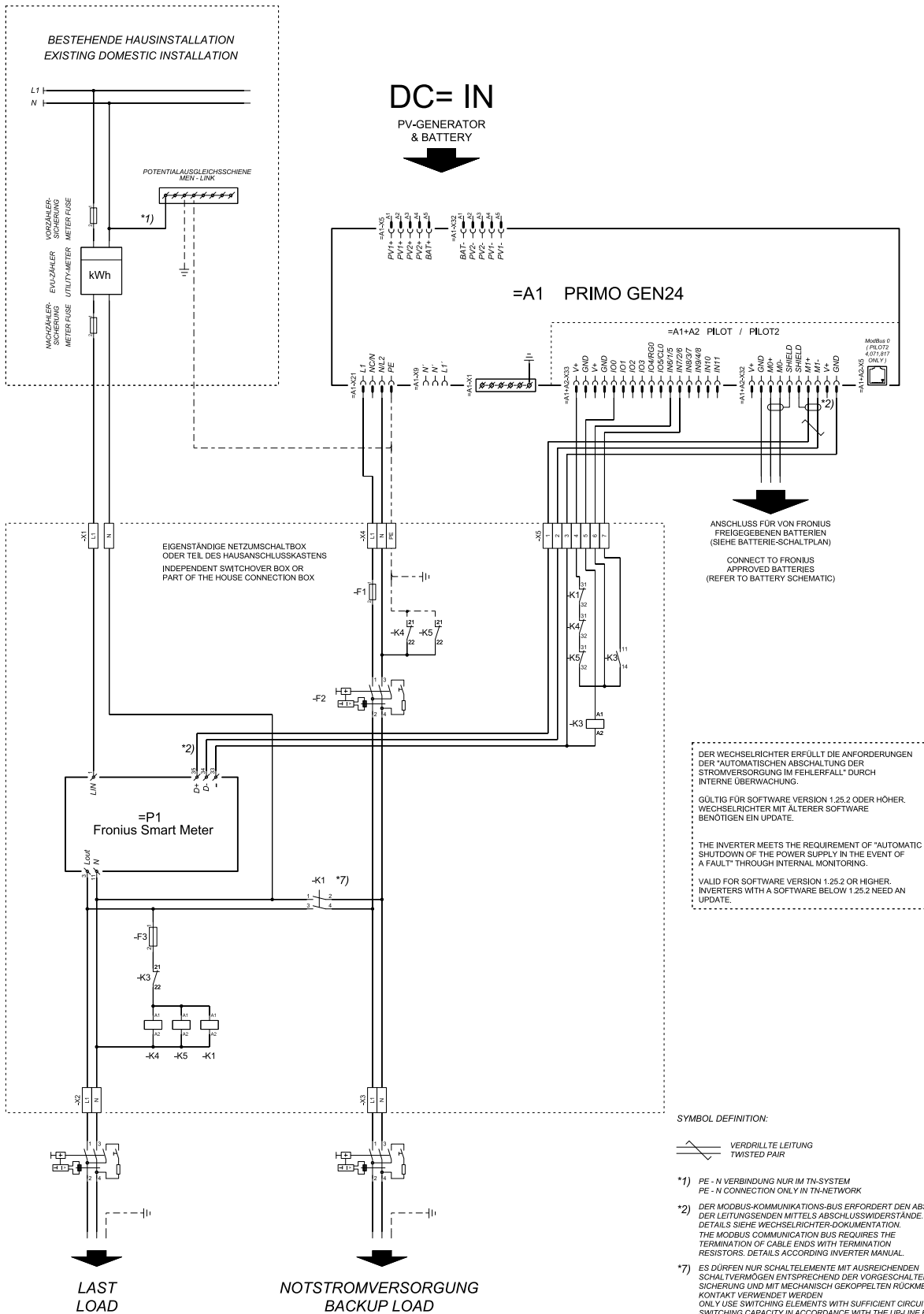

# Automatic switch to backup power 2-pin double separation with ext. grid and system protection - e.g., Italy

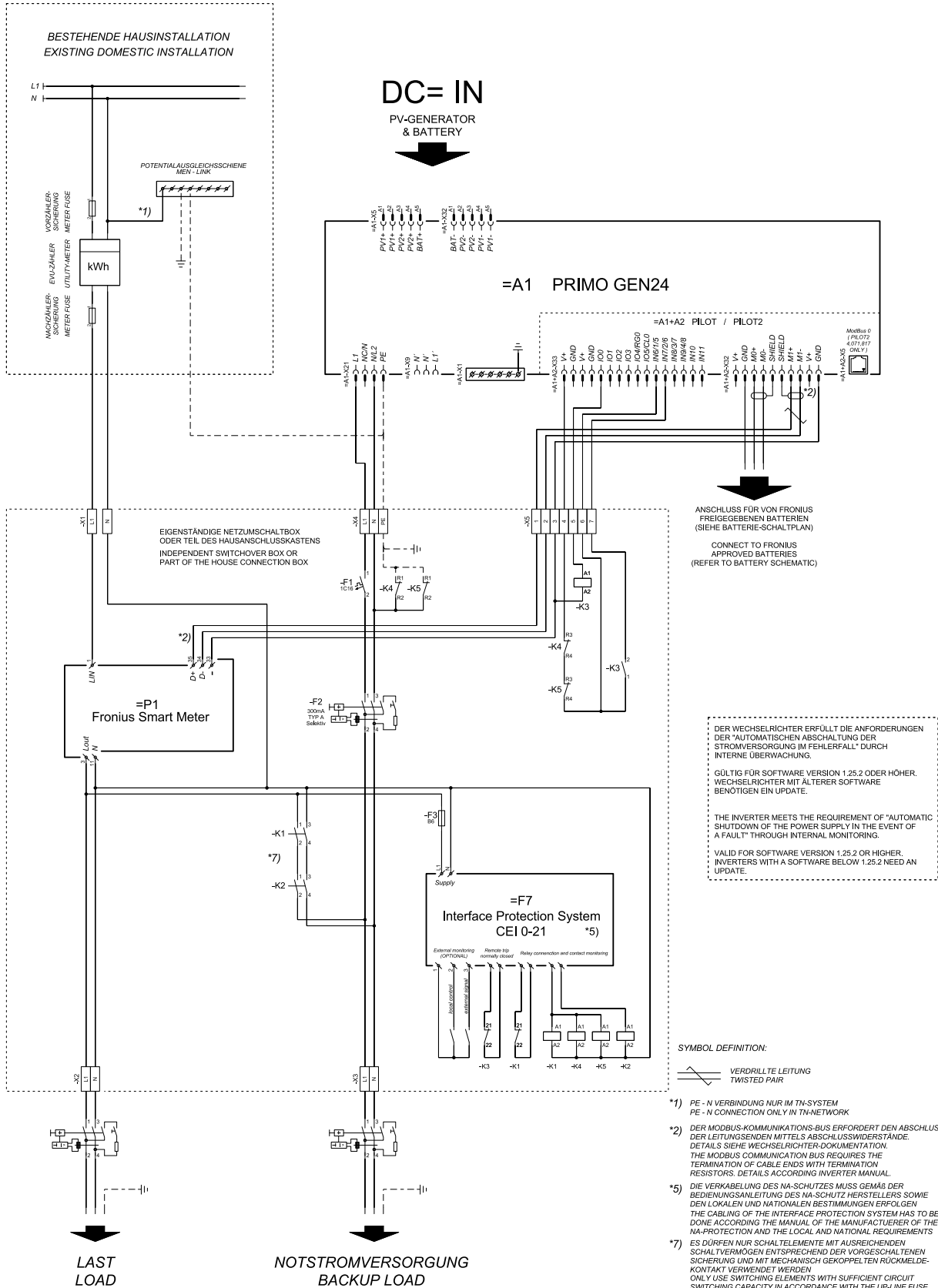

# Fronius Primo GEN24 with Enwitec Box

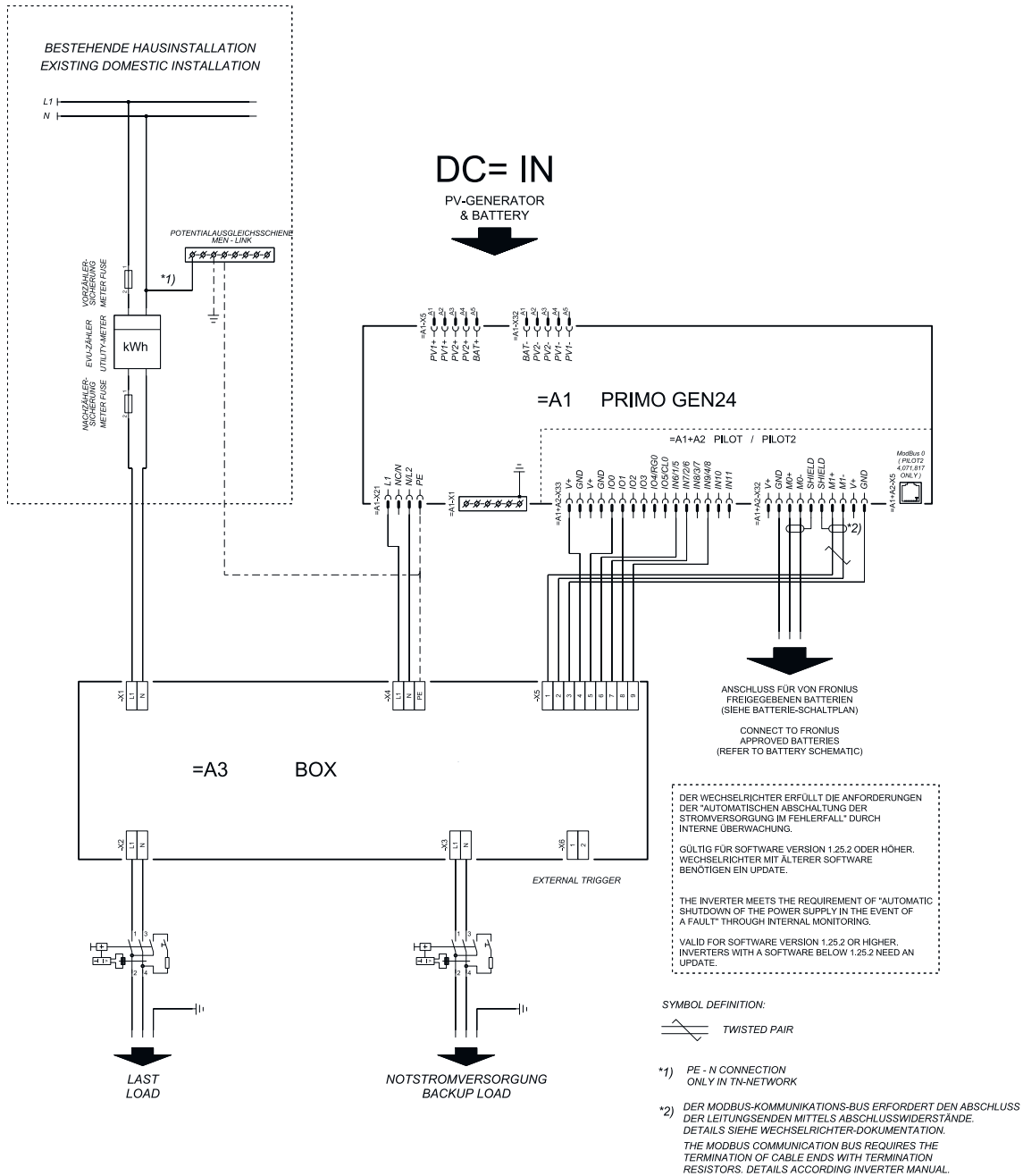



# **Circuit diagrams—manual switch to backup power with Fronius Backup Switch**

# Manual switch to backup power 1-pin separation, e.g., Australia

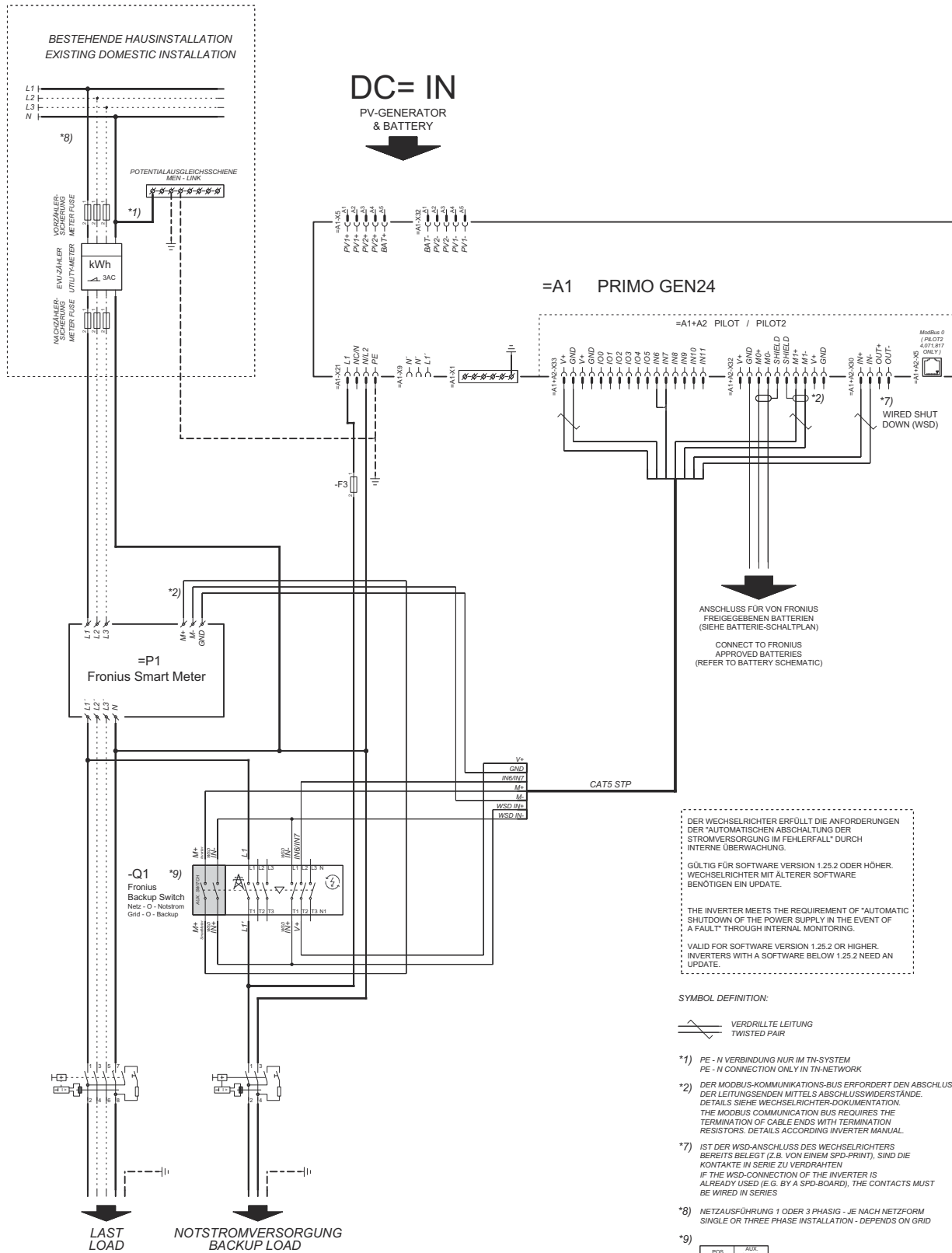

# Manual switch to backup power 2-pin separation, e.g., Germany

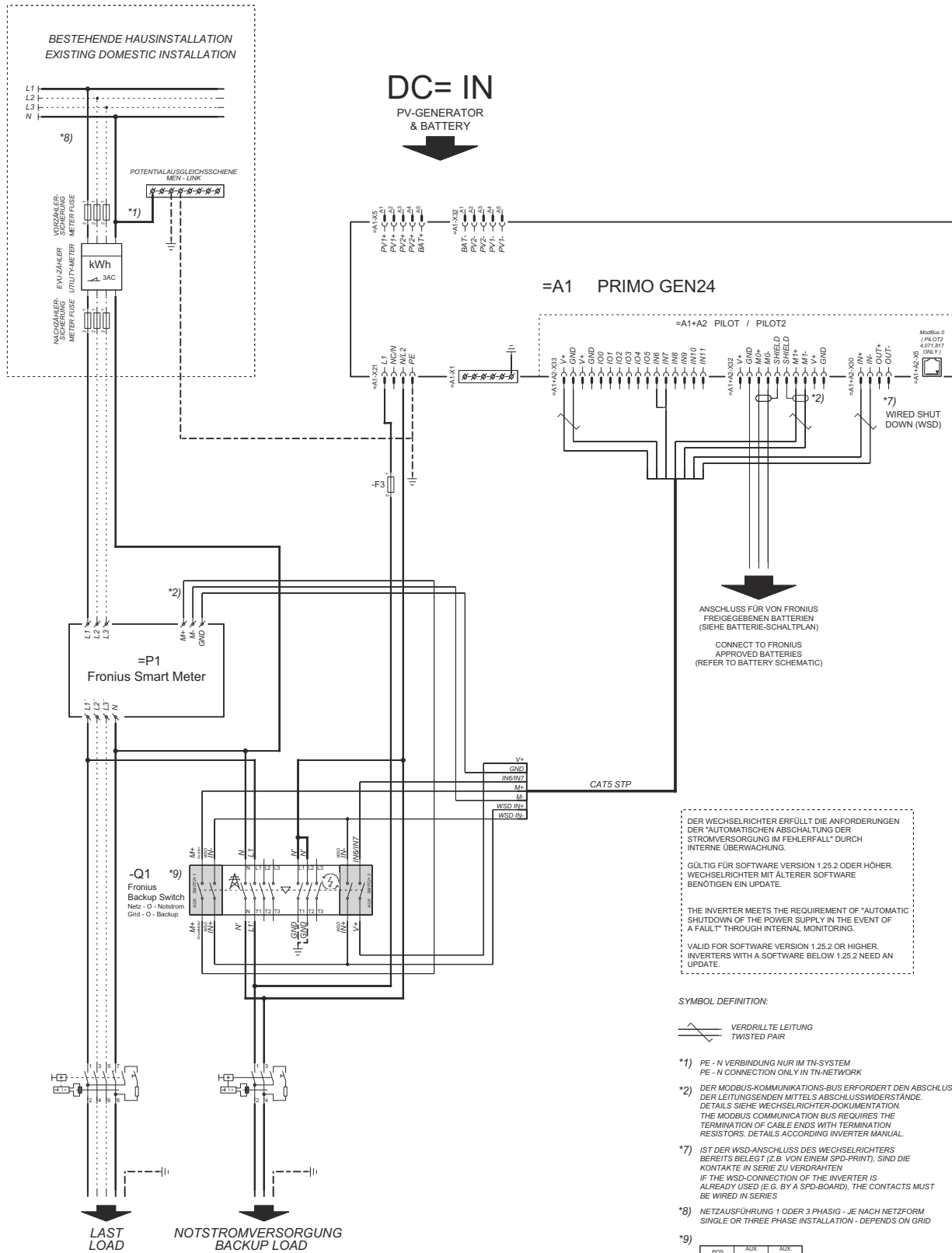



# **Dimensions of the inverter**

# Fronius Primo GEN24 SC / Fronius Primo GEN24 Plus SC

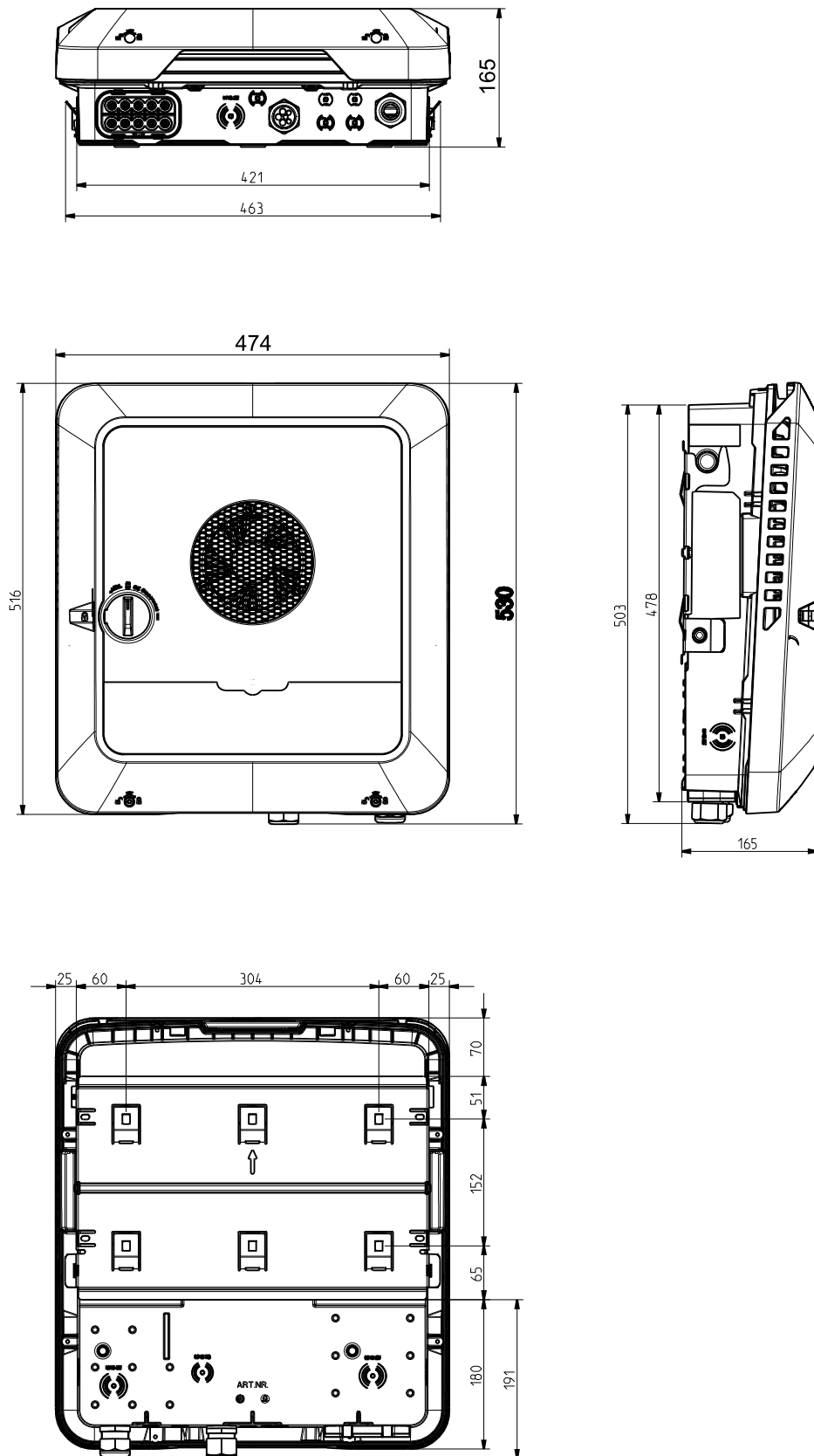









[fronius.com/en/solar-energy/installers-partners/products-solutions/monitoring-digital-tools](https://fronius.com/en/solar-energy/installers-partners/products-solutions/monitoring-digital-tools)

**MONITORING &  
DIGITAL TOOLS**

**Fronius International GmbH**

Froniusstraße 1  
4643 Pettenbach  
Austria  
[contact@fronius.com](mailto:contact@fronius.com)  
[www.fronius.com](http://www.fronius.com)

At [www.fronius.com/contact](http://www.fronius.com/contact) you will find the contact details of all Fronius subsidiaries and Sales & Service Partners.