



Founded in 1946

Project: _____

Items: _____

Quantity: _____

Approval: _____

Date: _____

Security Cages

- Constructed steel, powder coated silver, with all steel mesh sides
- See through mesh keeps merchandise visible at all times.
- Two hinged doors with base and top locking mechanism with pad lock (sold separately) keeps merchandise secure.
- Units have three shelves, two are adjustable on 1" increments with quick clips. Easily adjust the space between the shelves to accommodate a variety of merchandise. Additional shelves are available. Cage has a push handle to assist with steering.
- Maneuvers easily on two 6" swivel plate casters and two 6" rigid plate casters, two with brakes.





Founded in 1946

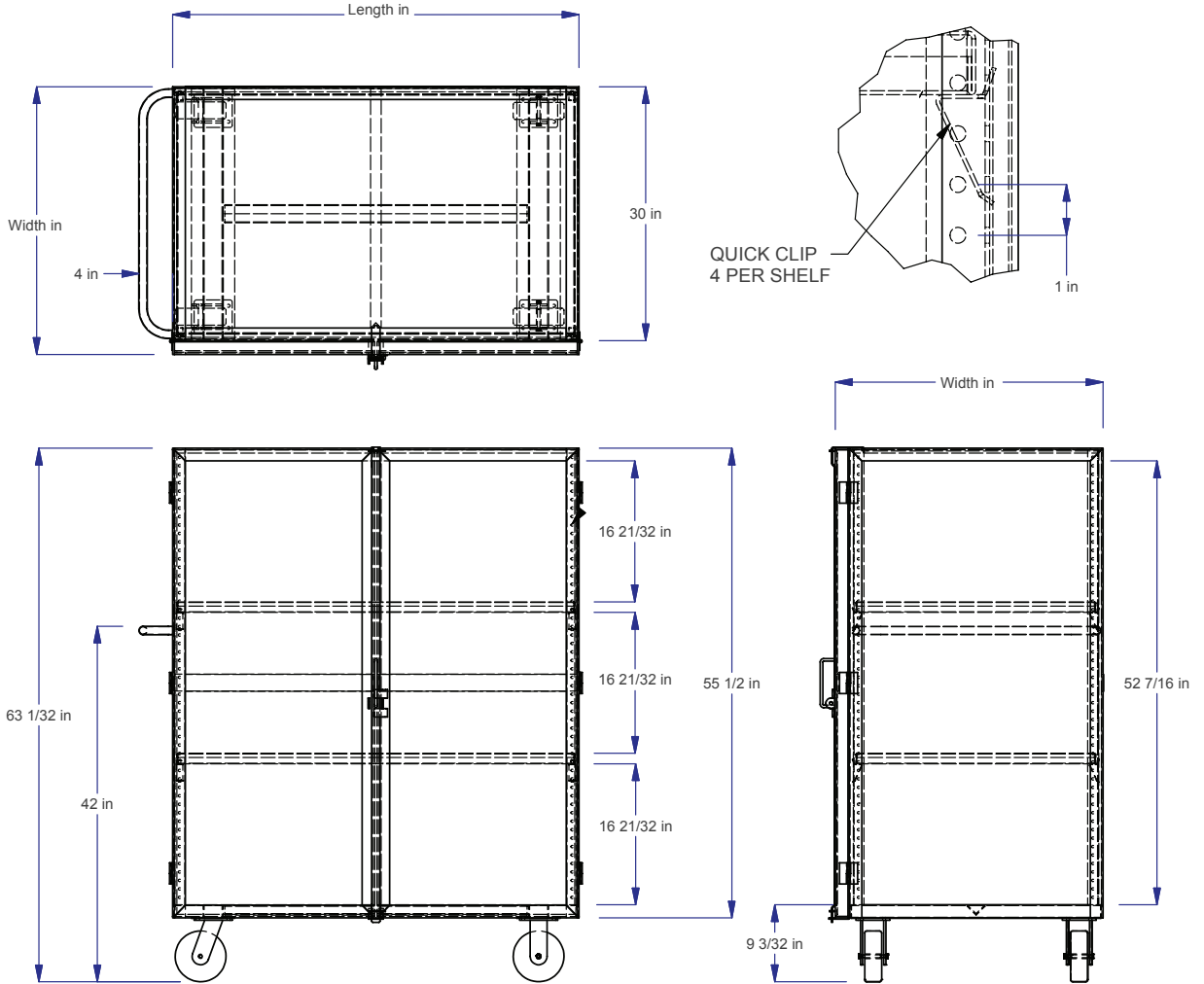

Model Number	Overall Dimensions						Capacity		Approx. Ship Wt	
	Width		Length		Height		(lb)	(kg)	(lb)	(kg)
	(in)	(mm)	(in)	(mm)	(in)	(mm)				
EC-3-2448/2ADJ	24	610	48	1219	63	1600	2000	907	310	140
EC-3-2460/2ADJ	24	610	60	1524	63	1600	2000	907	330	150

Caster Information
 Swivel Plate Caster w/ 6" x 2" Phenolic Wheel & Brakes 7311BK (211115)
 Rigid Plate Caster w/ 6" x 2" Phenolic Wheel 746 (123481)
 6" x 2" Phenolic Wheel 7119 (122331)
 Freight Class: 250

In line with our poicy to continually improve our products, Winholt reserves the right to change materials and specifications without notice. 5.2015