

Project: _____
Items: _____
Quantity: _____
Approval: _____
Date: _____

Stainless Steel Hand Sanitizer Stand

Safely offer your customers and patrons peace of mind by offering them convenient and complimentary hand sanitizer while they are in your establishment.

Features:

- Sanitary stainless steel construction
- Free standing unit, 12" x 12" square base
- Adjustable to hold virtually any height sanitizer container

Benefits

- Sanitary NSF approved
- Stable 14 gauge base, will not tip
- Versatile stand can hold many sizes of hand sanitizer, easily adjusts to fit any height container up to 16"
- Perfect to use anywhere in your establishment

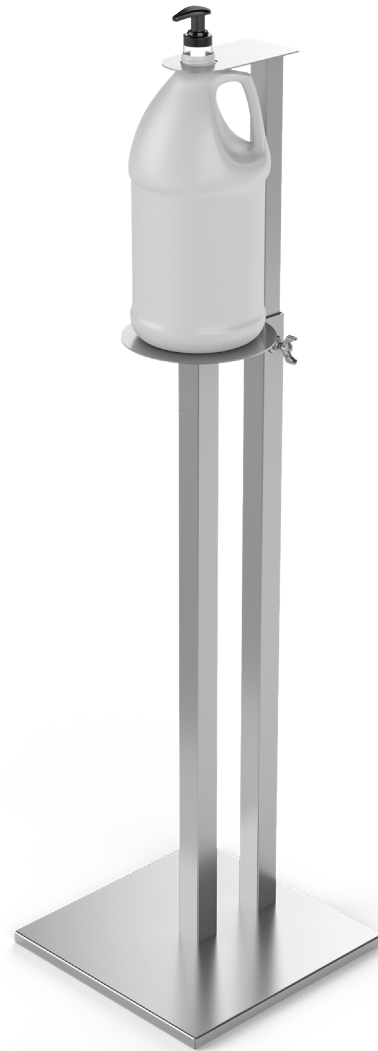
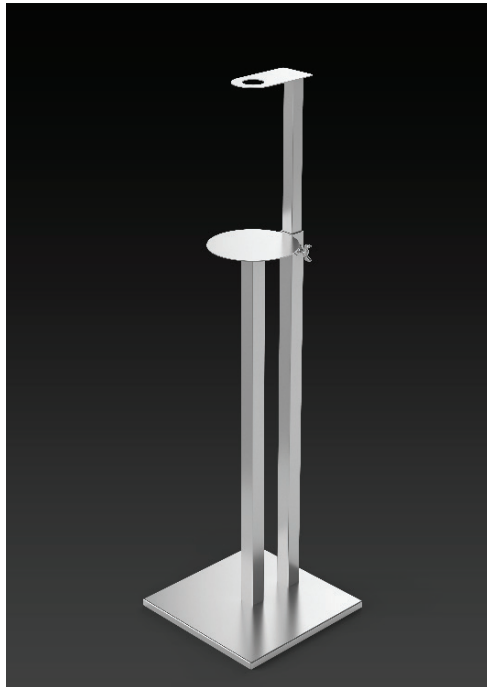

Model SS1212DT





Founded in 1946

Stainless Steel Hand Sanitizer Stand

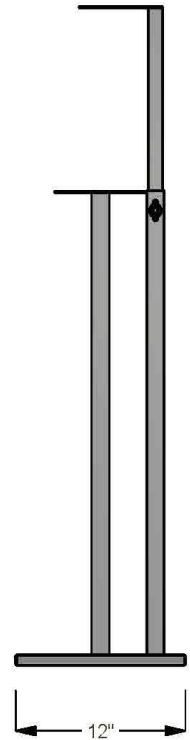
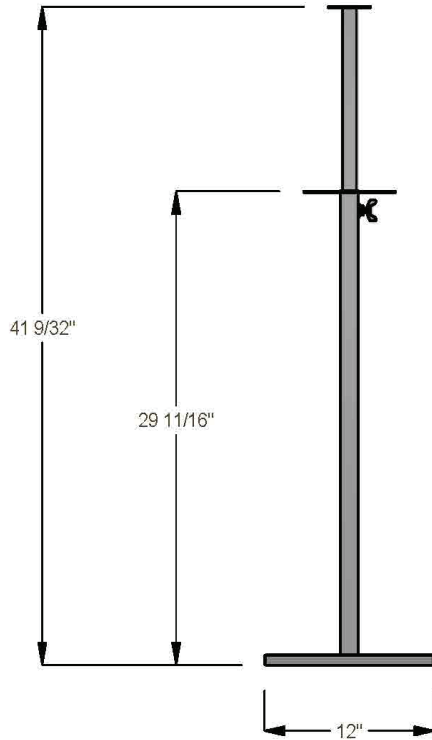
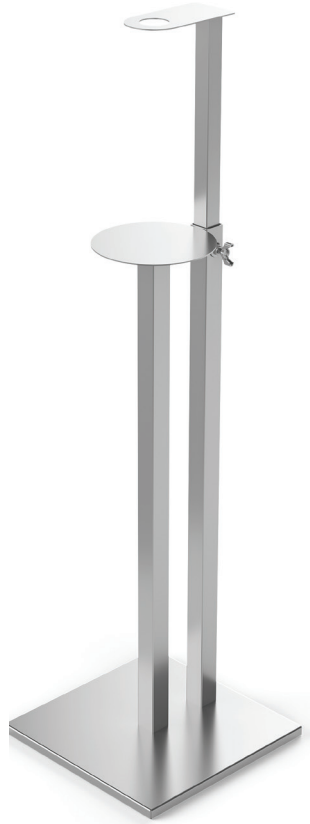

Model Number	Order#	Overall Dimensions						Approx. Ship Wt	
		Width		Length		Height			
		(in)	(mm)	(in)	(mm)	(in)	(mm)	(lb)	(kg)
SS1212DT	1143244	12	305	12	305	41.25	1049	20	9.07



In line with our policy to continually improve our products, Winholt reserves the right to change materials and specifications without notice.