

# Aurora Refrigerated Sandwich/Salad Prep Table, Stainless Steel

ITEM:	59045	59034	59046	59047	59048
MODEL:	PT-CN-0686E-HC	PT-CN-0920E-HC	PT-CN-1194E-HC	PT-CN-1524E-HC	PT-CN-1787E-HC



## Aurora Refrigerated Sandwich/Salad Prep Table helps you create your signature sandwiches and salads quickly and easily.

This refrigerated prep table line boasts a spacious working area, allowing for extra ingredient storage. Plus, it's environmentally friendly and energy-efficient thanks to the Hydro-Carbon R290 refrigerant it uses.

High-quality stainless steel construction provides durability and longevity and guarantees maximum hygiene and food-grade standards.

### FEATURES:

- Stainless Steel exterior & interior
- Removable door gasket
- Adjustable heavy-duty PVC coated shelves
- Self-closing doors
- Heavy-duty casters with brakes
- Digital temperature controller
- Cutting Board Thickness: 10 mm

Telephone: 1-800-465-0234

Fax: (905) 607-0234

Email: sales@omcan.com

Website: www.omcan.com

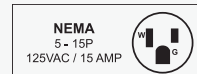

Authorized Dealer

**WARRANTY**  
 2 YEARS PARTS AND LABOUR  
 5 YEARS ON COMPRESSOR

**TECHNICAL SPECIFICATION**

Features	28" wide	36" wide	47" wide	60" wide	70" wide
Item	59045	59034	59046	59047	59048
Model	PT-CN-0686E-HC	PT-CN-0920E-HC	PT-CN-1194E-HC	PT-CN-1524E-HC	PT-CN-1787E-HC
Capacity	7.1 cu. ft. (201 L)	9.1 cu. ft. (258 L)	12.6 cu.ft. (357 L)	16.6 cu.ft. (469 L)	19.5 cu.ft (553 L)
Number of Doors	1 Swing Door - Solid Door	2 Swing Door - Solid Door		3 Swing Doors - Solid Door	
Self-Closing Door	Yes				
Number of Pans	6 x 1/6 pans 2 x 1/9 pans	10 x 1/6	12 x 1/6 pans or 6 x 1/3 pans	16 x 1/6 pans	18 x 1/6 pans
Number of Shelves	1	2		3	
Shelf Material	Plastic Coated				
Shelf Capacity	88 lb. (40 kg.)				
Number of Casters	YES (4)				
Power	372W	420W	408W	504W	670W
Amps	3.6 A	1.2 A	4.1 A	5 A	6.7 A
Electrical	110V-120V / 60Hz / 1Ph				
Temperature Controller	Digital				
Temperature Range	0.5°C - 4.4°C (33°F - 40°F)				
Refrigerant	R290				
Insulation Material	Cyclopentane				
Cooling System	Ventilated				
Defrosting	Automatic				
Cutting Board Dimensions (WDH)	27.5" x 10.3" x 0.4" (696 x 262 x 10 mm)	36.2" x 10.3" x 0.4" (920 x 262 x 10 mm)	46.8" x 10.3" x 0.4" (1188 x 262 x 10 mm)	60.2" x 10.3" x 0.4" (1529 x 262 x 10 mm)	70.4" x 10.3" x 0.4" (1787 x 262 x 10 mm)
Interior Dimensions (WDH)	42.6" x 19.8" x 23.5" (615 x 504 x 597 mm)	33" x 19.8" x 23.5" (837 x 504 x 597 mm)	43" x 19.8" x 23.5" (1091 x 504 x 597mm)	56.5" x 19.8" x 23.5" (1434 x 504 x 597mm)	66.6" x 19.8" x 23.5" (1691 x 504 x 597 mm)
Net Weight	176 lb. (80 kg.)	220.5 lb. (100 kg.)	253.5 lb. (115 kg.)	319.7 lb. (145 kg.)	343.9 lb. (156 kg.)
Net Dimensions (WDH)	27.5" x 29.5" x 41.5" (698 x 750 x 1055 mm)	36.2" x 29.5" x 41.5" (920 x 750 x 1055 mm)	46.8" x 29.5" x 42.3" (1188 x 750 x 1075mm)	60.2" x 29.5" x 42.3" (1529 x 750 x 1075mm)	70.4" x 29.5" x 42.3" (1787 x 750 x 1075 mm)
Gross Weight	232 lb. (105 kg.)	287 lb. (130 kg.)	304 lb. (138 kg.)	417 lb. (189 kg.)	452 lb. (205 kg.)
Gross Dimensions (WDH)	33" x 35" x 46" (830 x 880 x 1160 mm)	41" x 35" x 46" (1052 x 880 x 1160 mm)	52" x 35" x 46" (1320 x 880 x 1160mm)	65" x 35" x 46" (1660 x 880 x 1160 mm)	76" x 35" x 46" (1920 x 880 x 1160mm)
Plug Type	NEMA 5-15P				

TECHNICAL DRAWING (measurements are in mm)

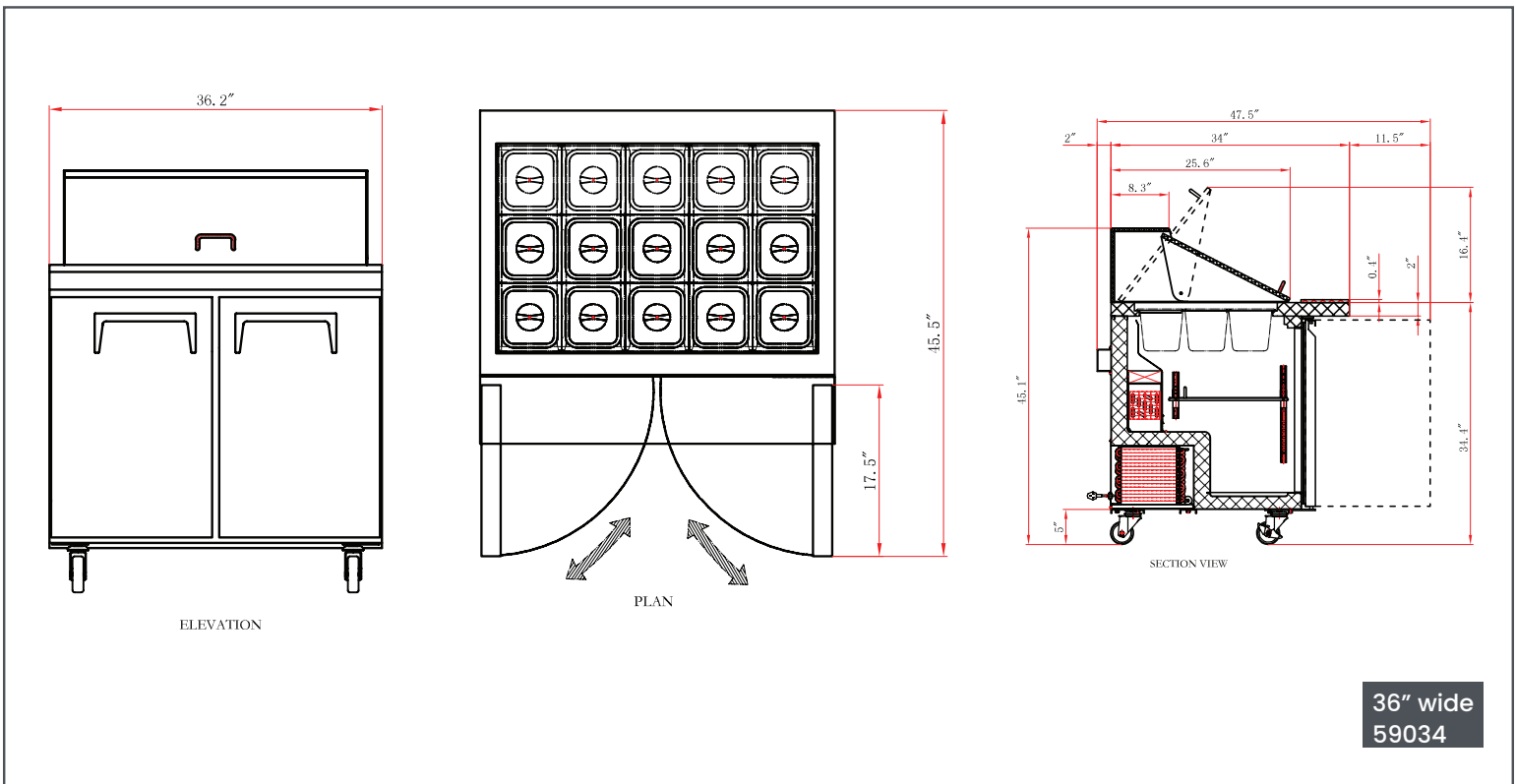
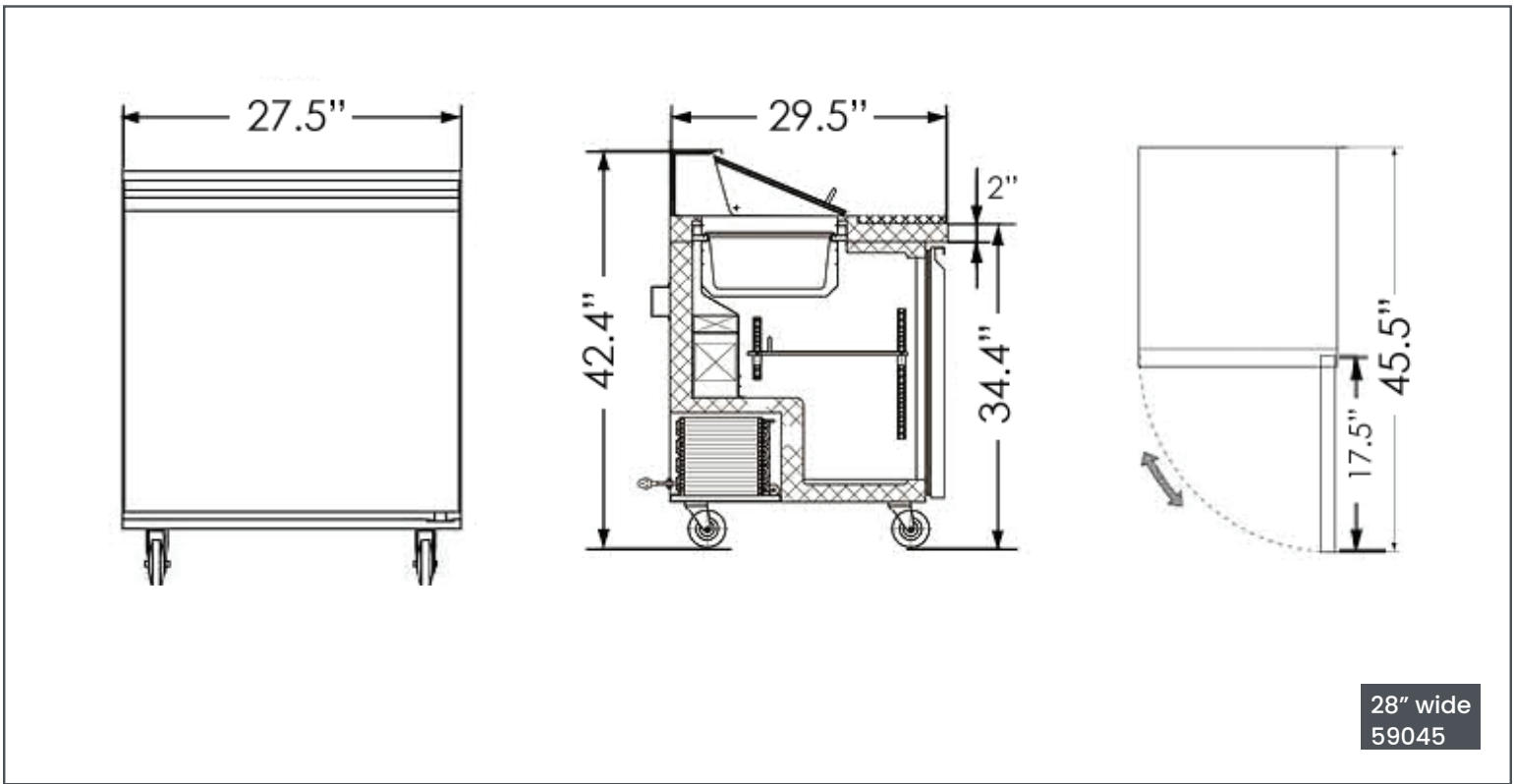

## TECHNICAL DRAWING (measurements are in mm)

