

LUXUS® THERMAL DISPENSERS LBD SERIES

Shown D020 23.0L / 12.0G and D022 91.0L / 24.0G
Mobile LUXUS® Thermal Dispensers



FEATURES

LBD HIGH VOLUME LUXUS® STATIONARY & MOBILE THERMAL DISPENSERS



QUANTITY WITH QUALITY

High-Capacity LBD Series Thermal Dispensers are the answer if you require transport for quick deployment of multiple gallons of hot, fresh coffee or refill service anywhere throughout your venue.



DURABILITY

Its sturdy construction and fully-insulated design make this dispenser a versatile addition to any high-volume environment.



AMAZING RESULTS

This high-volume dispensers delivers hot, fresh beverages for hours. Designed to work with large volume brewers, such as FETCO's CBS-71AC, CBS-72AC and TBS-71AC.



MOBILITY

Mobil LUXUS® dispensers are easy to maneuver and move to wherever it's needed, making dispensing a breeze.

DISPENSERS

LBD HIGH VOLUME LUXUS® STATIONARY & MOBILE THERMAL DISPENSERS

D019

23.0 Liter / 12.0 Gallon
LUXUS® Thermal
Dispenser
LBD-6

NSF



D020

23.0 Liter / 12.0 Gallon
Mobile LUXUS®
Thermal Dispenser
LBD-6C

NSF



D021

69.0 Liter / 18.0 Gallon
Mobile LUXUS®
Thermal Dispenser
LBD-18

NSF



D022

91.0 Liter / 24.0 Gallon
Mobile LUXUS®
Thermal Dispenser
LBD-24

NSF



ACCESSORIES

LBD HIGH VOLUME LUXUS® STATIONARY & MOBILE THERMAL DISPENSERS

SERVING STATION & COUNTER FOR HIGH VOLUME DISPENSERS



All dispensers and serving stations **SOLD SEPARATELY**.

WATER FILTRATION SYSTEM

Filtration System	Item Number	Item Description	Rated Capacity	Working Pressure	Weight
Everpure®	A039	In-Line System	113,563 liters	10-125 psi [0.7-8.6 bar], non-shock	6.0 lbs / 2.7 kg
Everpure®	A075	Replacement Cartridge	113,563 liters	10-125 psi [0.7-8.6 bar], non-shock	6.0 lbs / 2.7 kg
BWT Bestmax	A138	In-Line System	3,002 liters	29-116 psi [2-8 bar], non-shock	11.0 lbs / 5.0 kg
BWT Bestmax	A139	Replacement Cartridge	3,002 liters	29-116 psi [2-8 bar], non-shock	11.0 lbs / 5.0 kg
BWT Bestmax	A140	In-Line System	4,562 liters	29-116 psi [2-8 bar], non-shock	11.0 lbs / 5.0 kg
BWT Bestmax	A141	Replacement Cartridge	4,562 liters	29-116 psi [2-8 bar], non-shock	11.0 lbs / 5.0 kg



SET INCLUDES: 1ea. commercial quality corrosion resistant filter head 1ea. taste and odor filter cartridge (FETCO® #A075) / 1ea. 3/8" x 4' connection hose / 1 set — mounting bracket and hardware.

- Recommended for large-sized operations
- Taste and odor filter for extremely turbid (cloudy) water
- Granular-activated carbon reduces sediment and chlorine
- Quick-disconnect style head/cartridge design cartridge for effortless replacement
- Durable, corrosion-resistant head includes built-in shutoff valve



SET INCLUDES: 1ea. filter cartridge / 1ea. universal filter head / 1ea. wall mounting bracket Braided hose supplies 3/8" and 3/4" compression, in 24" or 48" lengths

- Recommended for small- to medium-sized operations
- Carbonate hardness removal prevents scale deposits and retains minerals
- Granular-activated carbon reduces sediment and chlorine
- Quick-disconnect style head/cartridge design cartridge for effortless replacement
- Durable, corrosion-resistant head includes built-in shutoff valve
- Four bypass settings allows for different water qualities and product preferences

LUXUS® THERMAL DISPENSERS

DIMENSIONS

LBD-6 6.0 GALLON LUXUS® STATIONARY THERMAL DISPENSER¹

DIMENSIONS					WEIGHT		
[in] / [cm]	Height (A)	Width (B)	Depth (C)	Faucet Clearance (D)	[lbs] / [kg]	Empty	Filled
Product Dimensions	16.7 42.5	17.4 44.4	21.7 55.2	0.4 1.0	Product Weight	40.0 18.1	90.0 40.8
Shipping Dimensions	26.0 66.0	24.0 61.0	23.0 58.5	N/A	Shipping Weight	44.0 20.0	N/A

LBD-6C 6.0 GALLON LUXUS® MOBILE THERMAL DISPENSER

DIMENSIONS					WEIGHT		
[in] / [cm]	Height (E)	Width (F)	Depth (G)	Faucet Clearance (H)	[lbs] / [kg]	Empty	Filled
Product Dimensions	53.5 135.9	18.0 45.7	30.0 76.2	8.00-12.0 22.8-30.5	Product Weight	228.0 103.4	278.0 126.1
Shipping Dimensions	62.0 157.5	42.0 107.0	48.0 122.0	N/A	Shipping Weight	231.5 105.0	N/A

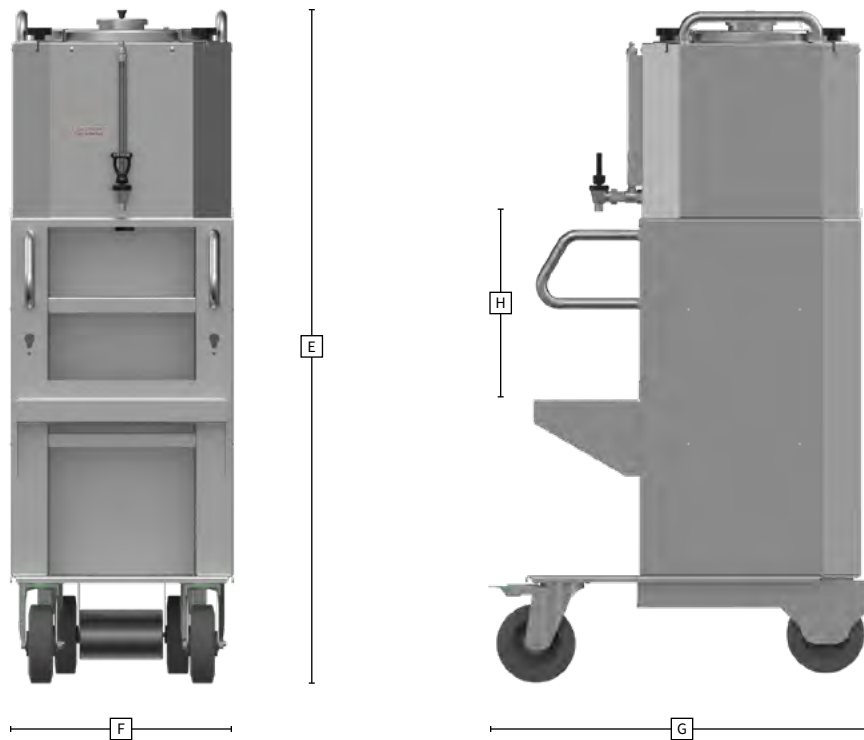
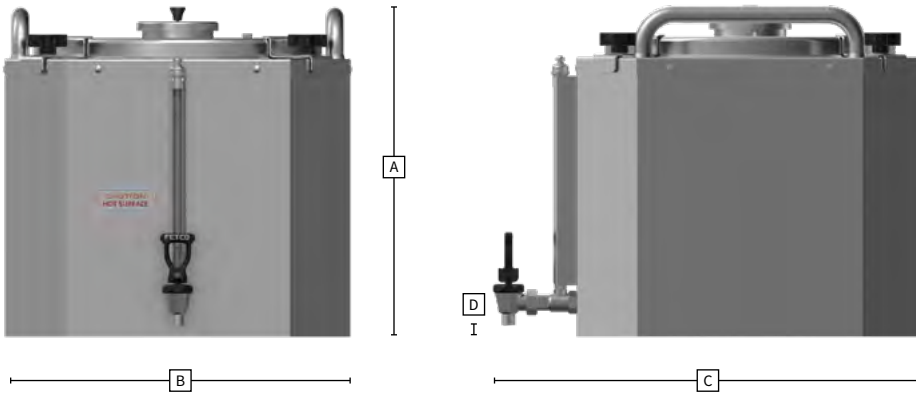

DIMENSIONS

LBD-18 18.0 GALLON LUXUS® MOBILE THERMAL DISPENSER

DIMENSIONS					WEIGHT		
[in] / [cm]	Height (A)	Width (B)	Depth (C)	Faucet Clearance (D)	[lbs] / [kg]	Empty	Filled
Product Dimensions	53.5 135.9	18.0 98.4	30.0 66.7	8.00-12.0 22.8-30.5	Product Weight	315.0 142.9	464.9 210.9
Shipping Dimensions	62.0 157.5	48.0 122.0	42.0 107.0	N/A		Shipping Weight	320.0 145.0

LBD-24 24.0 GALLON LUXUS® MOBILE THERMAL DISPENSER

DIMENSIONS						WEIGHT		
[in] / [cm]	Height (A)	Width (B)	Depth (C)	Faucet Clearance (E)	High Volume Faucet Clearance (F)	[lbs] / [kg]	Empty	Filled
Product Dimensions	53.5 135.9	18.0 98.4	30.0 66.7	8.00-12.0 22.8-30.5	7.00-9.00 17.7-22.8	Product Weight	310.0 140.6	509.9 231.3
Shipping Dimensions	62.0 157.5	48.0 122.0	42.0 107.0	N/A	N/A		Shipping Weight	322.0 146.0

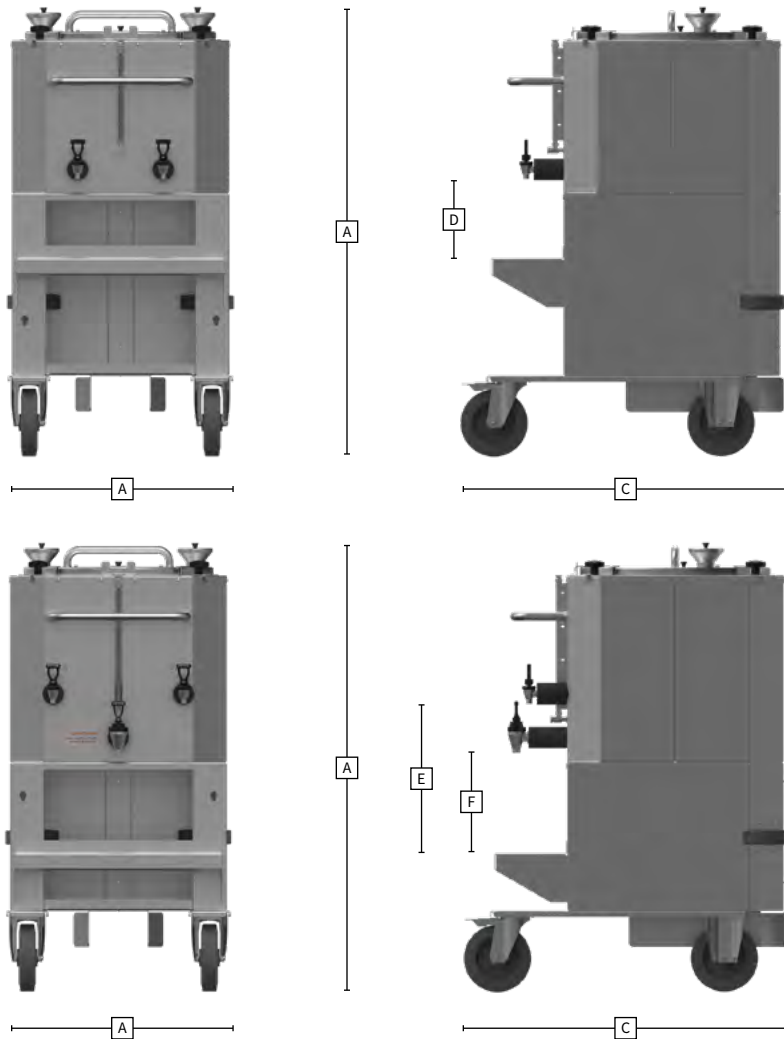

DIMENSIONS



FAX
+1.847.719.3001