



PROJECT:	MODEL:	QUANTITY:	ITEM NO:

NON-HEATED PATIENT TRAY DELIVERY CABINETS

14" x 18", or 15" x 20" or 16" x 22" Patient Trays

SINGLE DEEP - NON-HEATED / NON-INSULATED "ETC PATIENT TRAY TRANSPORT" SERIES

FWE's quiet ride, all stainless steel meal delivery carts provide maximum reliability and are perfect for locations that require concentration and tranquility.



- 1** Versatility - stainless steel tray racks hold wide varieties of trays - easily adjustable to accommodate tray changes in your healthcare operations
- 2** Cleanability - stainless steel is favored by operators because it does not rust and is easy to clean. Other sanitary standard features include: antimicrobial SaniGuard magnetic door handles, lift-off doors and pitched center drain
- 3** Mobility - even when fully loaded, these carts move with ease. 6" cart wash casters mounted to stress plates absorb shock during room service delivery. Hidden, magnetic door hold open feature allows for compact unloading and out-of-the-way in hallways
- 4** Noise suppression - FWE's patient tray delivery carts feature standard sound dampening components: latchless door design, rubber door stoppers, rack grommets and quiet ride casters
- 5** Hospitals need durable foodservice equipment. FWE's food delivery carts take the abuse of any transport applications. Standard features include: tubular welded stainless steel frame, full perimeter bumper, heavy-duty stainless steel hinges, solid tubular push bar handle and vented ends (allow excess heat and moisture to escape)
- 6** Serve hot and cold foods together using pellet systems, insulated or disposable containers - prepare meals ahead of time, then easily and quietly transport to serving location

ETC-12

**Two year limited warranty*

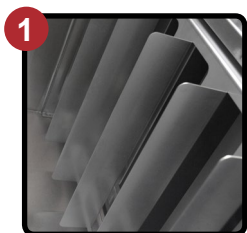

Stainless Steel Tray Racks



Antimicrobial SaniGuard Handle

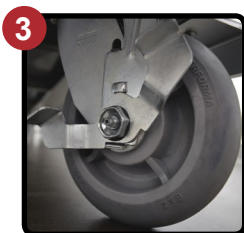

Cart Wash Casters



Serve Hot & Cold Foods Together (Shown with optional adjustable tray slides)



made to serve you better

SPECIFICATIONS: NON-HEATED PATIENT TRAY CARTS

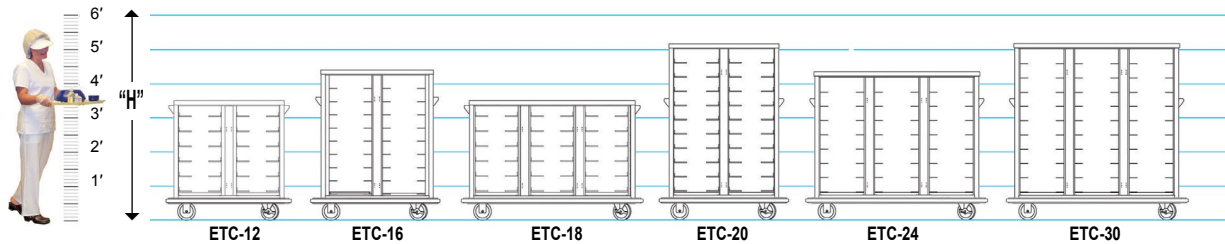

MODEL NUMBER	TRAY CAPACITIES [A]						OVERALL EXTERIOR DIMENSIONS IN. (mm)			CLASS 100		
	14" x 18", 15" x 20", or 16" x 22"						(Height Includes Casters)			NO. OF DOORS	CASTER SIZE	SHIP WT. LBS. (KG)
	NUMBER OF TRAYS AT SPACINGS OF:						HIGH "H"	DEEP "D"	WIDE "W"			
	3.0"	3.75"	4.5"	5.25" ^[B]	6.0"	6.75"						
ETC-12	20	16	14	12	10	10	42.5" (1080)	27.5" (698)	46.75" (1187)	2	6"	285 (129)
ETC-16	28	22	18	16	14	12	53" (1346)	27.5" (698)	46.75" (1187)	2	6"	315 (143)
ETC-18	30	24	21	18	15	15	42.5" (1080)	27.5" (698)	66.75" (1695)	3	6"	370 (168)
ETC-20	34	28	24	20	18	16	63.5" (1613)	27.5" (698)	46.75" (1187)	2	6"	350 (159)
ETC-24	42	33	27	24	21	18	53" (1346)	27.5" (698)	66.75" (1695)	3	6"	420 (191)
ETC-30	51	42	36	30	27	24	63.5" (1613)	27.5" (698)	66.75" (1695)	3	6"	520 (236)

[A] Rack accommodates 14" x 18", 15" x 20", 16" x 22" trays by adjusting the position of the racks on alignment pins.

[B] Model numbers are based on capacities @ spacings of 5.25". Other spacings are available at time of order.

• Pass-thru Door [add "P"] is available on all model sizes except the ETC-30.

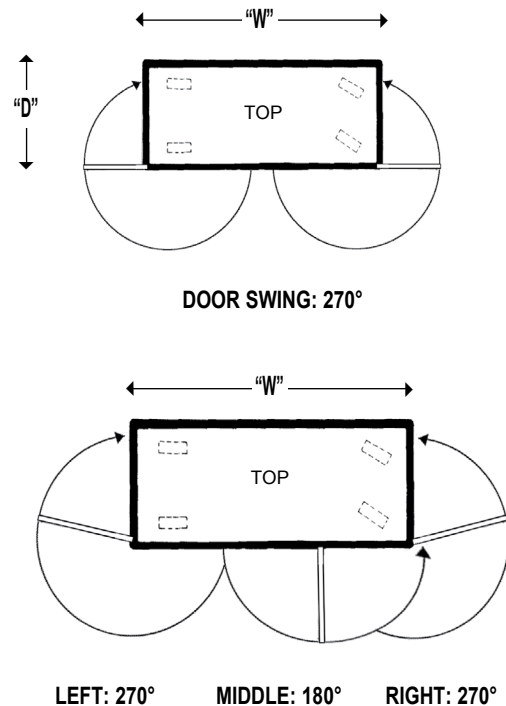

CONSTRUCTION. Heliarc welded, single unit construction of 18-gauge stainless steel. Welded tubular base frame shall be 1" square, heavy gauge stainless steel tubing, with 10-gauge stainless steel reinforcing plates at corners and fittings. Cabinets shall have vented ends on each side of the unit.

PUSH BAR HANDLE. Heavy-duty, 1" diameter tubular stainless steel push handles, mounted at each end of the unit. Mountings reinforced with stainless steel channel.

BUMPER. Solid 1.5" wide continuous wraparound aluminum channel, bolted to frame, with snap-in, non-marking replaceable vinyl cushion. Full perimeter bumper extends beyond doors, handles, etc., for added protection. Shall be continuous, with corner cut-outs to facilitate cleaning.

DOORS AND LATCHES. Flush mounted, stainless steel insulated doors. Each door shall have two (2) heavy-duty, lift-off, 12-gauge stainless steel hinges. The hinge mountings are reinforced with stainless steel backing plates. Each door shall be equipped with a positive closing, flush-in-door, antimicrobial SaniGuard magnetic door handle. Each door shall be equipped with a hidden, magnetic door hold open feature.

CASTERS. Maintenance free, Cart Wash polyurethane tire casters with stainless steel bearing. Standard in a configuration of two (2) rigid and two (2) swivel with brake. Casters shall have a reinforced yoke mounted to 10-gauge caster plate. The caster mounting plate shall be secured to a 10-gauge stainless steel reinforcing stress plate via welded in place stainless steel studs. The reinforcing stress plates shall be welded to the heavy gauge tubular frame of the unit.

TRAY SLIDES. Unitized tray slide assemblies shall be heavy gauge stainless steel, channels fixed in place at 5.25" spacings. Assemblies are designed to accommodate one (1) 14" x 28", 15" x 20" or 16" x 22" trays. Removable stainless steel uprights shall easily lift off heavy-duty stainless steel supports without the use of tools. Each upright assembly contains four (4) sets of alignment holes that mount to fixed top and bottom alignment pins welded to cabinet floor and ceiling. Other spacings are available at time of order (consult factory).

PITCHED DRAIN. Cabinet shall have a pitched center drain to facilitate thorough cleaning of interior.

Optional Accessories

- DOORS**
- See-thru Lexan door
 - Pass-thru door
 - Key locking door latch
 - Padlocking transport latch
 - Paddle latch
 - Alternate door swing configurations
- CASTERS**
- All swivel or larger casters
 - 6 caster configuration
- SPACINGS**
- Uprights with adjustable tray slides (option available at no additional cost)
 - Custom tray rack spacing
- EXTRAS**
- Security packages
 - Cold plate cartridge
 - Menu card holder
 - Dry erase board
 - Grounding strap
 - Top guard rail (3 or 4 sided)
 - Top corner bumpers
 - Beverage um angles (on select models)
 - Drain plug

FWE products may be covered under one or more of the following U.S. patents: 288,299; 238,300; 3,952,609; 4,192,991. All rights reserved. All specifications subject to change without notice. Errors subject to correction.
© 15 Food Warming Equipment Company, Inc. R.15.02



FOOD WARMING EQUIPMENT COMPANY, INC.

5599 HWY. 31 W. Portland, TN 37148
800.222.4393 | 815.459.7500 | Fax: 815.459.7989
www.FWE.com | sales@fwe.com

