



REACH-IN

SPLIT DOOR REFRIGERATOR MODEL R1R-29-2

The Model R1R-29-2 represents Randell's *Standard Series* reach-ins in a single section, split door refrigerator. This model is designed to provide maximum menu flexibility in a small vertical footprint. The single compressor system is designed to meet the latest DOE energy standards and is balanced with the highest quality components and controls to provide exceptional performance for the operator.

STANDARD FEATURES:

- Energy efficient single compressor system
- Digital controls
- Digital temperature read-outs
- Automatic adaptive defrost system
- Efficient hot gas condensate evaporator
- Door activated LED interior lighting
- Adjustable, heavy duty, coated wire shelves
- 9' cord and plug
- Door lock with integral door clasp
- 5" casters (front two locking)
- Door pressure relief valve

CABINET CONSTRUCTION:

- Exterior Front: Stainless Steel
- Exterior Sides: Stainless Steel
- Exterior Body: Galvanized Steel
- Interior Sides: Anodized Aluminum
- Interior Floor: Stainless Steel

Insulation is foamed in place high density polyurethane. Units provided with coated wire shelves with rear vertical turn-up to assure proper air flow. Each shelf is adjustable. Unit is provided with 5" casters (field installed) are affixed to bottom of unit.

DOORS:

- Exterior: Stainless Steel
- Interior: Anodized Aluminum

Both doors are self-closing with torsion type concealed hinges providing a clean exterior look suitable for front of the house installations. The door stays open after 90-degrees for easy loading. Cabinet is provided with door pressure relief device to assist in easy opening of the doors. Interior is illuminated with energy-efficient LED lights on door activated switch.

REFRIGERATION SYSTEM: Self-contained compressor refrigeration system using R-290 is balanced to regulate interior mounted evaporator coil providing superior air circulation to the storage compartment. Top-mounted compressor design provides easier access for preventative maintenance and condenser cleanings and accumulates less dirt than bottom-mount compressors. Condensate is evaporated by a rear mounted hot gas system that has protective coating on hot gas loop for extended life. Refrigerator is designed to operate between 33°F and 38°F. Standard settings are easily managed by simple up/down arrows. The controllers also have lighted door open indicators which are followed by three low-volume beeps after the door is open for thirty seconds as well as fan-on indicators.

ELECTRICAL: Unit comes from the factory prewired with a 9ft. cord and plug and ready for plugging into a dedicated 115/60/1 phase, 15-amp outlet.

PROJECT NAME:

LOCATION:

ITEM NO:

QTY:

MODEL NO:

AIA NO:

SIS NO:

CSI SECTION: 11400



OPTIONS/ACCESSORIES:

- Extra interior shelves

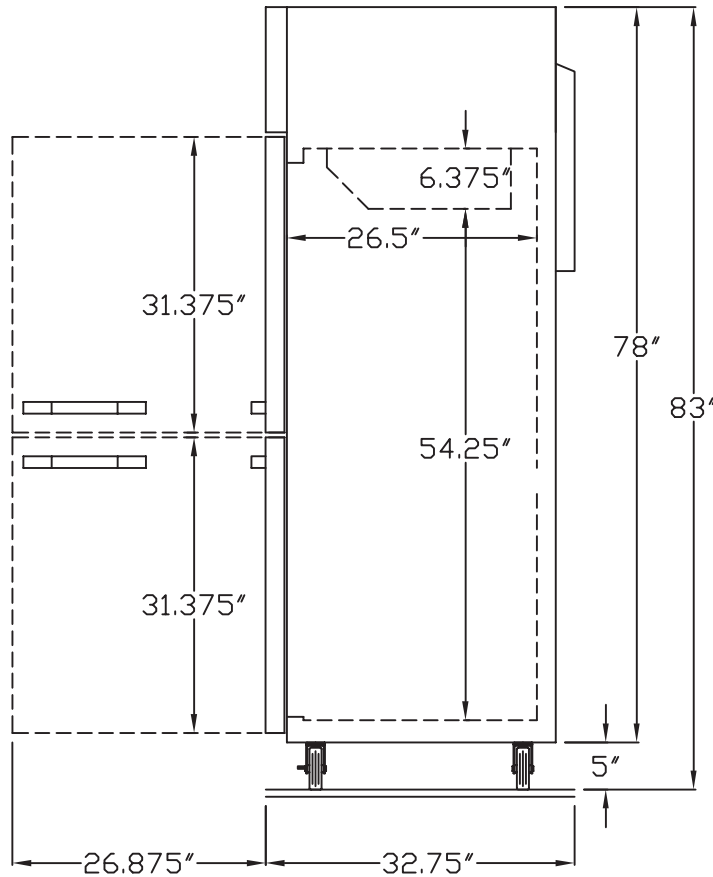
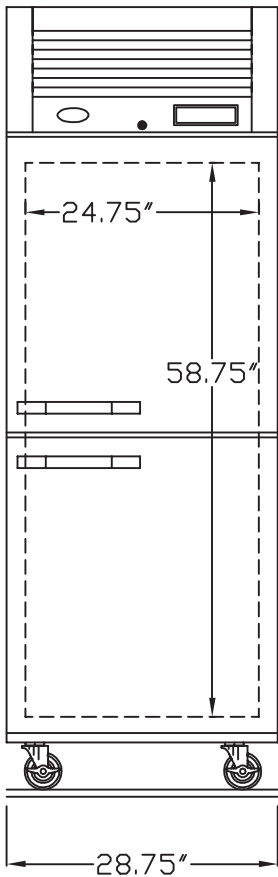
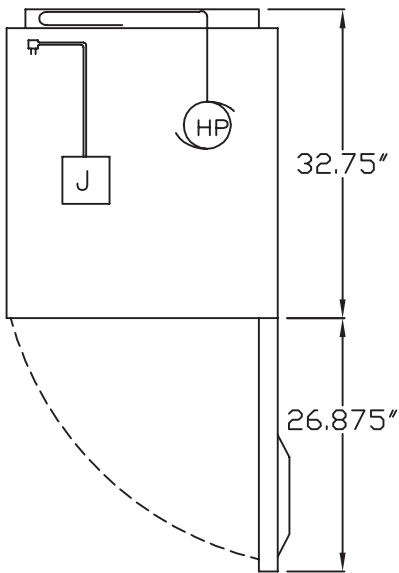

Model	Hinged	L	D	H	Doors	Storage Cu. Ft.	Shelves	HP	Power	Amps	NEMA	Ship Wt.
R1R-29-2	Right	28.75"	32.75"	83"	(2) 1/2	21	3	1/4	115/60/1	2.5	5-15P	270