

Dell PowerEdge R360

Technical Guide

Notes, cautions, and warnings

 **NOTE:** A NOTE indicates important information that helps you make better use of your product.

 **CAUTION:** A CAUTION indicates either potential damage to hardware or loss of data and tells you how to avoid the problem.

 **WARNING:** A WARNING indicates a potential for property damage, personal injury, or death.

Chapter 1: System overview	5
Key workloads.....	5
New technologies.....	5
Chapter 2: System features and generational comparison	7
Chapter 3: Chassis views and features	9
Front view of the system.....	9
Rear view of the system.....	10
Inside the system.....	12
Chapter 4: Processor	13
Processor features	13
Supported processors.....	13
Chapter 5: Memory subsystem	15
Supported memory.....	15
Chapter 6: Storage	16
Storage controllers.....	16
Storage controller feature matrix.....	16
Supported Drives.....	18
Hard Disk Drives (HDDs).....	18
Solid State Drives (SSDs).....	20
Internal storage configuration.....	22
External Storage.....	22
Chapter 7: Networking	23
Supported network cards	23
Overview.....	23
Chapter 8: PCIe subsystem	24
PCIe risers.....	24
Chapter 9: Power, thermal, and acoustics	26
Power.....	26
Power Supply Units.....	27
Thermal.....	28
Thermal design.....	28
Acoustics.....	29
Acoustical performance.....	29
Chapter 10: Rack, rails, and cable management	31

Rack Rails.....	31
Chapter 11: Operating Systems and Virtualization.....	37
Supported Operating Systems.....	37
Chapter 12: Dell Systems Management.....	38
Integrated Dell Remote Access Controller (iDRAC).....	38
Systems Management software support matrix.....	39
Chapter 13: Appendix D: Service and support.....	41
Why attach service contracts.....	41
ProSupport Infrastructure Suite	41
Specialty Support Services.....	43
ProDeploy Infrastructure Suite.....	44
Supplemental Deployment Services	47
Unique Deployment Scenarios.....	48
DAY 2 – Automation Services with Ansible.....	49
Dell Technologies Consulting Services.....	49
Chapter 14: Appendix A: Additional specifications.....	51
Chassis dimensions	51
Chassis weight.....	52
NIC port specifications.....	52
Video specifications.....	52
USB Ports.....	53
PSU rating.....	54
Environmental specifications.....	55
Particulate and gaseous contamination specifications.....	56
Thermal restriction matrix.....	57
Thermal air restrictions.....	58
Chapter 15: Appendix A. Standards compliance.....	59
Chapter 16: Appendix C Additional resources.....	60

System overview

The Dell PowerEdge R360 is a powerful entry-level one-socket rack server designed to meet the evolving computing demands from organizations.

The system features:

- One Intel® Xeon® 6300 series or one Xeon® E-2400 series processor or one Intel® Pentium® processor
- Four DDR5 DIMM slots
- Two redundant AC or DC power supply units
- PCI Express® (PCIe) 4.0 enabled expansion slots
- Up to:
 - 8 x 2.5-inch SAS/SATA
 - 4 x 3.5 inch SAS/SATA
 - 6 x 2.5 inch SAS/SATA HDD/SSD + 2 x 2.5 inch NVMe
- Onboard LAN ports

Topics:

- [Key workloads](#)
- [New technologies](#)

Key workloads

PowerEdge R360 is versatile enough to address many customer segments and workloads affordably, that includes:

- Collaboration/Sharing: Built-in features to enable collaborative applications between groups of people that share information and processes on-site or remotely.
- ROBO Business/Database: Provide computing performance for ROBO business and database workloads including mailing, data process and analysis.
- Near Edge: Suitable form-factor for near-edge computing with GPU applications, such as video and audio analysis, surveillance, and VDI

New technologies

Table 1. New technologies

Technology	Detailed Description
Intel® Xeon® 6300 series processor/ Intel® Xeon® E-2400 series processor	Core count: Up to 8 core processor
	Maximum number of PCIe lanes: Integrated 16 PCIe Gen5 lanes @ 32 GT/s, 4 PCIe Gen4 lanes @ 16GT/s
	Maximum TDP: 95 W
Intel® Pentium® G7400/ G7400T processor	Core count: Up to 2 core processor
	Maximum number of PCIe lanes: Integrated 16 PCIe Gen5 lanes @ 32 GT/s, 4 PCIe Gen4 lanes @ 16GT/s
	Maximum TDP: 46 W
4800 MT/s DDR5 Memory	Maximum 4 DIMM slots per system
	Supports DDR5 ECC UDIMM up to 4400 MT/s
Flex I/O	LOM, 2x 1 GB with BCM5720 LAN controller

Table 1. New technologies (continued)

Technology	Detailed Description
	Rear I/O with: <ul style="list-style-type: none"> ● 1 GB Dedicated Management Network Port ● USB 3.0 x1 ● USB 2.0 x1 ● VGA port ● Serial port Front I/O with: <ul style="list-style-type: none"> ● USB 2.0 x1 ● Dedicated iDRAC Direct micro-USB x 1
CPLD 1-wire	Support payload data of Riser, BOSS-N1, BP, and Rear I/O to BIOS and iDRAC
Dedicated PERC	PERC 11
Power Supplies	60 mm dimension is the new PSU form factor design.
	600 W AC/DC Platinum
	700 W AC/DC Titanium

System features and generational comparison

The following table shows the comparison between the PowerEdge R360 with the PowerEdge R350.

Table 2. Features comparison

Features	PowerEdge R360	PowerEdge R350
Processors	One Intel® Xeon® 6300 series or one Xeon® E-2400 series processor with up to 8 cores or one Intel® Pentium® processor with up to 2 cores	One Intel® Xeon® E-2300 series processors with up to 8 cores or one Intel® Pentium® processor with up to 2 cores
Memory	Up to 4 x DDR5 ECC UDIMMs DIMM Speed: Up to 4400 MT/s	Up to 4 x DDR4 UDIMMs DIMM Speed: Up to 3200 MT/s
Storage Controllers	Internal Controllers: PERC H355, PERC H755, PERC H355f, PERC H755f, HBA355i, HBA355i (front)	Internal Controllers: PERC H355, PERC H355f, PERC H345, PERC H755, PERC H755f, HBA355i, PERC H345f, HBA355f
	External Controllers: HBA355e	External Controllers: HBA355e
	Software RAID: S160	Software RAID: S150
Drive Bays	Front: Up to 4 x 3.5-inch SAS/SATA (HDD/SSD) Up to 8 x 2.5-inch SAS/SATA (HDD/SSD) Up to 6 x 2.5-inch hot-swappable SAS/SATA drives through PERC + 2 x 2.5-inch direct attach NVMe	Front: Up to 4 x 3.5-inch SAS/SATA (HDD/SSD) Up to 8 x 2.5-inch SAS/SATA (HDD/SSD)
Power Supplies	600 W Mixed Mode Platinum 100 V-240 V AC or 240 V DC. Hot Swap redundant	600 W Mixed Mode Platinum 100 V-240 V AC or 240 V DC. Hot Swap redundant
	700 W Mixed Mode Titanium 200 V-240 V AC or 240 V DC. Hot Swap redundant	700 W Mixed Mode Titanium 200 V-240 V AC or 240 V DC. Hot Swap redundant
Cooling Options	Air cooled	Air cooled
Fans	Up to 3 STD fans and 1 HPR fan	Up to 3 STD fans and 1 HPR fan
Dimension	H x W x D: 1U x 482 mm x 563.3 mm	H x W x D: 1U x 482 mm x 534.59 mm
Form Factor	1U	1U
Embedded Management	iDRAC9, iDRAC Direct, iDRAC RESTful API with Redfish, iDRAC Service Manual	iDRAC9 Enterprise, iDRAC Direct, Datacenter license options; iDRAC Service Module, iDRAC RESTful API with Redfish
Bezel	Security bezel or Optional Filter bezel	Optional LCD bezel or security bezel
OpenManage Software	<ul style="list-style-type: none"> • OpenManage Enterprise • OpenManage Power Manager plugin • OpenManage Service plugin 	<ul style="list-style-type: none"> • OpenManage Enterprise • OpenManage Power Manager plugin • OpenManage SupportAssist plugin

Table 2. Features comparison (continued)

Features	PowerEdge R360	PowerEdge R350		
	<ul style="list-style-type: none"> • OpenManage Update Manager plugin • CloudIQ for PowerEdge plug in • OpenManage Enterprise Integration for VMware vCenter • OpenManage Integration for Microsoft System Center • OpenManage Integration with Windows Admin Center 	<ul style="list-style-type: none"> • OpenManage Update Manager plugin 		
Mobility	OpenManage Mobile	OpenManage Mobile		
Integrations and Connections	<p>OpenManage Integrations</p> <ul style="list-style-type: none"> • BMC Truesight • Microsoft System Center • OpenManage Integration with ServiceNow • Red Hat Ansible Modules • Terraform Providers • VMware vCenter and vRealize Operations Manager 	<table border="1"> <tr> <td> <p>Integrations:</p> <ul style="list-style-type: none"> • Microsoft® System Center • VMware® vCenter™ and vRealize Operations Manager • BMC Truesight • Red Hat Ansible Modules </td> <td> <p>Connections:</p> <ul style="list-style-type: none"> • Nagios Core & Nagios XI • Micro Focus Operations Manager i (OMi) • IBM Tivoli Netcool/OMNibus • IBM Tivoli® Network Manager IP Edition </td> </tr> </table>	<p>Integrations:</p> <ul style="list-style-type: none"> • Microsoft® System Center • VMware® vCenter™ and vRealize Operations Manager • BMC Truesight • Red Hat Ansible Modules 	<p>Connections:</p> <ul style="list-style-type: none"> • Nagios Core & Nagios XI • Micro Focus Operations Manager i (OMi) • IBM Tivoli Netcool/OMNibus • IBM Tivoli® Network Manager IP Edition
<p>Integrations:</p> <ul style="list-style-type: none"> • Microsoft® System Center • VMware® vCenter™ and vRealize Operations Manager • BMC Truesight • Red Hat Ansible Modules 	<p>Connections:</p> <ul style="list-style-type: none"> • Nagios Core & Nagios XI • Micro Focus Operations Manager i (OMi) • IBM Tivoli Netcool/OMNibus • IBM Tivoli® Network Manager IP Edition 			
Security	<ul style="list-style-type: none"> • Cryptographically signed firmware • Data at Rest Encryption (SEDs with local or external key mgmt) • Secure Boot • Secured Component Verification (Hardware integrity check) • Secure Erase • Secured-core server • Silicon Root of Trust • System Lockdown (requires iDRAC9 Enterprise or Datacenter) • TPM 2.0 FIPS, CC-TCG certified, TPM 2.0 China NationZ 	<ul style="list-style-type: none"> • TPM 1.2/2.0 FIPS, CC-TCG certified, TCM 2.0 optional • Cryptographically signed firmware • Silicon Root of Trust • Secure Boot • System Lockdown (requires iDRAC9 Enterprise or Datacenter) • Secure Erase 		
Embedded NIC	2 x 1 GbE LOM	2 x 1 GbE LOM		
Networking Options	Optional Network Card	Optional Network Card		
GPU Options	Up to 1 x 60 W SW	None		
Ports	<p>Front: 1 x USB 2.0, 1x iDRAC Direct (Micro-USB)</p> <p>Rear: 1 x VGA, 1 x USB2.0 + 1 x USB 3.2 Gen1</p> <p>Internal : USB 3.2 Gen1</p>	<p>Front: 1 x USB 2.0, 1 managed (micro USB) + front VGA</p> <p>Rear: 1 x Gen2 + 1 x Gen3 USB</p> <p>Optional Internal USB</p>		
PCIe	Up to 2 x PCIe Slots Gen4	Up to 2 x PCIe Slots Gen4		
Operating System and Hypervisors	<ul style="list-style-type: none"> • Canonical Ubuntu Server LTS • Microsoft Windows Server with Hyper-V • Red Hat Enterprise Linux • SUSE Linux Enterprise Server • VMware ESXi <p>For specifications and interoperability details, see OS support.</p>	<ul style="list-style-type: none"> • Canonical® Ubuntu® LTS • Citrix® Hypervisor • Microsoft® Windows Server® LTSC with Hyper-V • Red Hat® Enterprise Linux • SUSE® Linux Enterprise Server <p>For specifications and interoperability details, see Dell.com/OSsupport</p>		

Chassis views and features

Topics:

- Front view of the system
- Rear view of the system
- Inside the system

Front view of the system



Figure 1. Front view of 4 x 3.5-inch drive system

Table 3. Features are available on the front of the system for a 3.5-inch drive system

Item	Ports, panels, and slots	Icon	Description
1	Left control panel	N/A	Contains the system health, system ID, and the status LED indicator.
2	3.5-inch drive or 2.5-inch drive in 3.5-inch carrier adapter.	NA	Enables you to install drives that are supported on your system. .
3	Right control panel	N/A	Contains the Power button, USB 2.0 port and iDRAC direct Micro USB port



Figure 2. Front view of 8 x 2.5-inch or 6 x 2.5-inch hot-swappable SAS/SATA drives through PERC + 2 x 2.5-inch direct attach NVMe drive system

Table 4. Features are available on the front of the system for a 2.5-inch drive system

Item	Ports, panels, and slots	Icon	Description
1	Left control panel	N/A	Contains the system health, system ID, and the status LED indicator.
2	2.5-inch drive	NA	Enables you to install drives that are supported on your system. .
3	Right control panel	N/A	Contains the Power button, USB 2.0 port and iDRAC direct Micro USB port

Rear view of the system

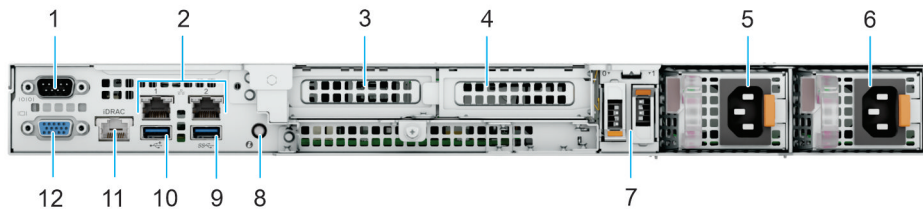





Figure 3. Rear view of the system

Table 5. Features available on the rear of the system

Item	Ports, panels, or slots	Icon	Description
1	Serial port	10101	Enables you to connect a serial device to the system.
2	NIC ports		The NIC ports that are integrated on the system board provide network connectivity.
3	PCIe expansion riser card slot 1	N/A	The expansion card riser enables you to connect PCI Express expansion cards.For more information, see the Expansion card installation guidelines section.
4	PCIe expansion riser card slot 2	N/A	The expansion card riser enables you to connect PCI Express expansion cards.For more information, see the Expansion card installation guidelines section.
5	Power supply unit (PSU 1)		Indicates the PSU.
6	Power supply unit (PSU 2)		Indicates the PSU.
7	BOSS-N1 module	N/A	BOSS-N1 module for internal system boot.

Table 5. Features available on the rear of the system (continued)

Item	Ports, panels, or slots	Icon	Description
8	System Identification (ID) button		<p>The System Identification (ID) button is available on the front and back of the system. Press the button to identify a system in a rack by turning on the system ID button. You can also use the system ID button to reset iDRAC and to access BIOS using the step through mode. When pressed, the system ID LED in the back panel blinks until either the front or rear button is pressed again. Press the button to toggle between on or off mode.</p> <p>i NOTE: If the server stops responding during POST, press and hold the System ID button for more than five seconds to enter the BIOS progress mode.</p> <p>i NOTE: To reset the iDRAC (if not disabled on the iDRAC setup page by pressing F2 during system boot), press and hold the System ID button for more than 15 seconds.</p>
9	USB 3.2 Gen1 port		This port is USB 3.2 Gen1-compliant.
10	USB 2.0 port		This port is USB 2.0-compliant.
11	Dedicated iDRAC Ethernet port	iDRAC	Enables you to remotely access iDRAC. For more information, see the Integrated Dell Remote Access Controller User's Guide at PowerEdge Manuals .
12	VGA port		Enables you to connect a display device to the system.

Inside the system

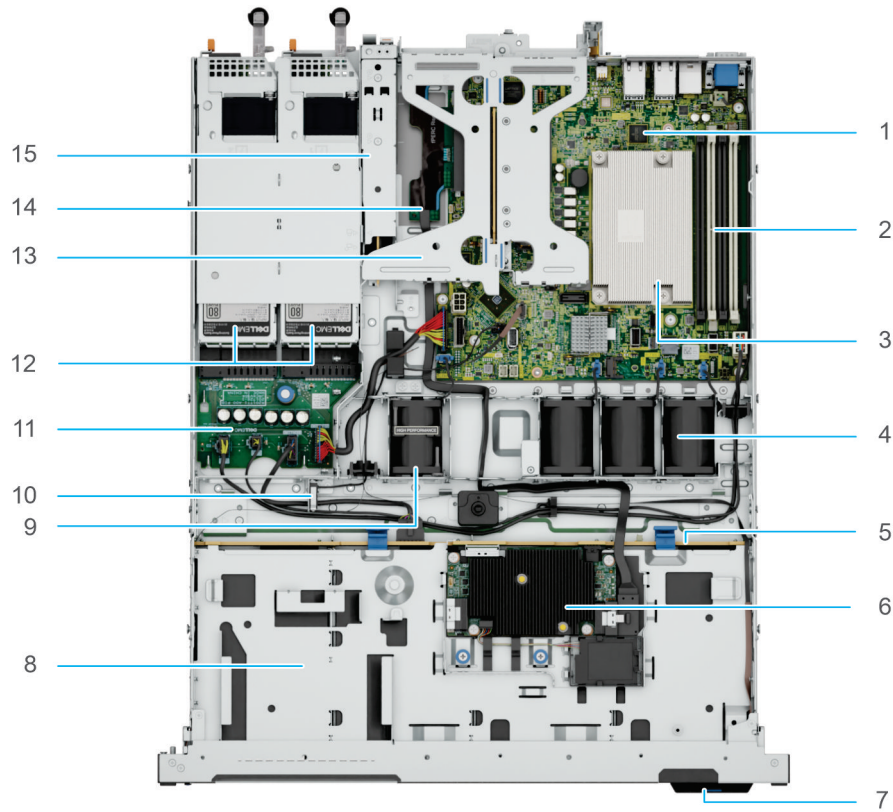

Figure 4. Inside the system

1. System board
2. DIMM slots
3. Processor heatsink
4. Standard (STD) cooling fans
5. Drive backplane
6. Front PERC card
7. Express Service Code Tag
8. Front drives
9. High Performance (HPR) fan - Optional
10. Intrusion switch
11. Power Interposer board (PIB)
12. Power supply units
13. Butterfly Riser with 2x PCIe slots
14. Front PERC card riser on the dedicated internal PCIe slot
15. BOSS N1 module

Processor

Topics:

- [Processor features](#)

Processor features

The following lists the features and functions that are in the upcoming Intel® Xeon® 6300 series Processor offering:

- For small businesses, the Xeon® 6300 series provides a reliable solution with business-ready servers to support business-critical services and customer data needs.
- For cloud service, the Xeon® 6300 series is the perfect option for Bare Metal Instances and Code/Data Security, with a cost-effective solution for essential performance to support entry-level bare metal services.

Key updates for the 6300 series include increased performance with a new processor core architecture:

- 4, 6, and 8 core option
- Up to 95 W TDP
- Up to 128 GB memory
- DDR5 up to 4800 MT/s

Supported processors

Table 6. Supported processors for PowerEdge R360

Processor	Clock Speed (GHz)	Cache (M)	Cores	Threads	Turbo	Memory Speed (MT/s)	Memory Capacity	TDP
6369P	3.3	24	8	16	Turbo	4800	128 GB	95 W
6357P	3.0	24	8	16	Turbo	4800	128 GB	80 W
6353P	2.7	24	8	16	Turbo	4800	128 GB	65 W
6349P	3.6	18	6	12	Turbo	4800	128 GB	95 W
6337P	3.5	18	6	12	Turbo	4800	128 GB	80 W
6333P	3.1	18	6	12	Turbo	4800	128 GB	65 W
6325P	3.5	12	4	8	Turbo	4800	128 GB	55 W
6315P	2.8	12	4	4	Turbo	4800	128 GB	55 W
E-2488	3.2	24	8	16	Turbo	4800	128 GB	95 W
E-2486	3.5	18	6	12	Turbo	4800	128 GB	95 W
E-2478	2.8	24	8	16	Turbo	4800	128 GB	80 W
E-2468	2.6	24	8	16	Turbo	4800	128 GB	65 W
E-2456	3.3	18	6	12	Turbo	4800	128 GB	80 W
E-2436	2.9	18	6	12	Turbo	4800	128 GB	65 W
E-2434	3.4	12	4	8	Turbo	4800	128 GB	55 W

Table 6. Supported processors for PowerEdge R360 (continued)

Processor	Clock Speed (GHz)	Cache (M)	Cores	Threads	Turbo	Memory Speed (MT/s)	Memory Capacity	TDP
E-2414	2.6	12	4	4	Turbo	4800	128 GB	55 W
G7400	3.7	6	2	4	No Turbo	4800	128 GB	46 W
G7400T	3.1	6	2	4	No Turbo	4800	128 GB	35 W

NOTE: Intel Xeon® 6300 series CPUs do not support Windows Server 2019.

NOTE: For information on supported operating systems for new CPUs, please see the links to specific OS versions and editions, certification matrices, Hardware Compatibility Lists (HCL) portal, and Hypervisor support are available at [Dell Enterprise Operating Systems](#).

Memory subsystem

Topics:

- Supported memory

Supported memory

Table 7. Memory technology

DIMM type	Rank	Capacity	DIMM rated voltage and speed	Operating Speed	
				1 DIMM per channel (DPC)	2 DIMM per channel (DPC)
ECC UDIMM	1 R	16 GB	DDR5 (1.1 V), 4800 MT/s	4400 MT/s	4000 MT/s
	2 R	32 GB	DDR5 (1.1 V), 4800 MT/s	4400 MT/s	3600 MT/s
	1 R	16 GB	DDR5 (1.1 V), 5600 MT/s	4400 MT/s	4000 MT/s
	2 R	32 GB	DDR5 (1.1 V), 5600 MT/s	4400 MT/s	3600 MT/s

Table 8. Supported DIMMs

Rated DIMM Speed (MT/s)	DIMM Type	DIMM Capacity (GB)	Ranks per DIMM	Data Width	DIMM Volts
4800	UDIMM	16	1	8	1.1
4800	UDIMM	32	2	8	1.1
5600	UDIMM	16	1	8	1.1
5600	UDIMM	32	2	8	1.1

Storage

Topics:

- Storage controllers
- Supported Drives
- Internal storage configuration
- External Storage

Storage controllers

NOTE: The size of the RAID 1 drives must be less than that of the second RAID container.

Dell's RAID controller options offer performance improvements, including the Adapter PERC solution. Adapter PERC provides a base RAID HW controller without consuming a PCIe slot by using a small form factor and high-density connector to the base planar.

Table 9. PERC Series controller offerings

Performance Level	Controller and Description
Entry	S160 - Windows software RAID
Value	HBA355i Adapter (Internal), HBA355i Front
Value Performance	H755 Adapter, H355 Adapter, PERC H355 Front, PERC H755 Front
External Controllers	HBA355e

NOTE: For more information about the features of the Dell PowerEdge RAID controllers (PERC), Software RAID controllers, or BOSS card, and on deploying the cards, see the storage controller documentation at [Storage Controller Manuals](#).

NOTE: H355 will replace H345 as the entry raid controller.

Storage controller feature matrix

Table 10. Storage controller feature matrix

Model and Form Factors	Interface Support	PCI Support	SAS Connection	Cache Memory Size	Write Back Cache	RAID Levels	Max Drive Support	RAID Support
PowerEdge Server-Storage Controllers (PERC and SAS HBA) Series 11								
H755 Adapter	12Gb/s SAS 6Gb/s SAS/SATA 3Gb/s SAS/SATA Gen3 (8 GT/s) NVMe	PCIe Gen 4	16 ports- 2x8 Internal	8 GB NV	Flash Backed Cache	0,1,5,6,10,50,60	16/ controller 50 with SAS Expander	Hardware

Table 10. Storage controller feature matrix (continued)

Model and Form Factors	Interface Support	PCI Support	SAS Connection	Cache Memory Size	Write Back Cache	RAID Levels	Max Drive Support	RAID Support
	Gen4 (16 GT/s) NVMe							
H755 Front	12Gb/s SAS 6Gb/s SAS/SATA 3Gb/s SAS/SATA Gen3 (8 GT/s) NVMe Gen4 (16 GT/s) NVMe	PCIe Gen 4	16 ports- 2x8 Internal	8 GB NV	Flash Backed Cache	0,1,5,6,10,50,60	16/ controller 50 with SAS Expander	Hardware
HBA355i Adapter	12Gb/s SAS 6Gb/s SAS/SATA 3Gb/s SAS/SATA	PCIe Gen 4	16 ports- 2x8 Internal	N/A	N/A	N/A	16/ controller 50 with SAS Expander	N/A
HBA355i Front	12Gb/s SAS 6Gb/s SAS/SATA 3Gb/s SAS/SATA	PCIe Gen 4	16 ports- 2x8 Internal	N/A	N/A	N/A	16/ controller 50 with SAS Expander	N/A
HBA355e Adapter	12Gb/s SAS 6Gb/s SAS/SATA 3Gb/s SAS/SATA	PCIe Gen 4	16 ports- 4x4 external	N/A	N/A	N/A	240	N/A
H355 Adapter	12Gb/s SAS 6Gb/s SAS/SATA	PCIe Gen 4	16 ports- 2x8 Internal	No Cache	No Cache	0,1,10	Up to 32 RAID, or 32 Non- RAID	Hardware
H355 Front	12Gb/s SAS 6Gb/s SAS/SATA	PCIe Gen 4	16 ports- 2x8 Internal	No Cache	No Cache	0,1,10	Up to 32 RAID, or 32 Non- RAID	Hardware
S160 Software RAID	Gen4 (16 GT/s) NVMe	PCIe Gen 4	N/A	No Cache	No Cache	0,1,5,10	Up to 8	Software RAID - Windows only

NOTE:

1. RAID 5/50 removed from entry RAID card
2. SWRAID support for Linux provides a pre-boot configuration utility to configure MDRAID and degraded boot capability.
3. For information, post-RTS, see the Storage controller documentation at [Storage Controller Manuals](#).

This document is updated as changes happen, so for the latest version be sure to bookmark it rather than downloading an offline copy or refer to the [Storage Controller Matrix](#) on sales portal.

Internal storage configuration

PowerEdge R360 supports the following internal storage configurations:

- 8 x 2.5 inch SAS/SATA RAID
- 4 x 3.5 inch SAS/SATA RAID
- 6 x 2.5-inch hot-swappable SAS/SATA drives through PERC + 2 x 2.5-inch direct attach NVMe

NOTE: The PowerEdge R360 system does not support rear storage.

Supported Drives

The table shown below lists the internal drives supported by the PowerEdge R360. Refer to Agile for the latest SDL.

Table 11. Supported Drives

Form Factor	Type	Speed	Rotational Speed	Capacities
2.5 inches	vSAS	12 Gb	SSD	960 Gb, 1.92 TB, 3.84 TB, 7.68 TB
	SAS	24 Gb	SSD	800 Gb, 960 GB, 1.6 TB, 1.92 TB, 3.84 TB, 7.68 TB
	SATA	6 Gb	SSD	480 Gb, 960 Gb, 1.92 TB, 3.84 TB
	NVMe	Gen4	SSD	800 GB, 960 GB, 1.6 TB, 1.92 TB, 3.2 TB, 3.84 TB, 7.68 TB
3.5 inches	SAS	12 Gb	7.2 K	4 TB, 8 TB, 12 TB, 16 TB
	SATA	6 Gb	7.2 K	2 TB, 4 TB, 8 TB, 12 TB, 16 TB

NOTE: For information on supported operating systems for NVMe features, please see the links to specific OS versions and editions, certification matrices, Hardware Compatibility Lists (HCL) portal, and Hypervisor support are available at [Dell Enterprise Operating Systems](#).

Hard Disk Drives (HDDs)

HDD feature matrix

Table 12. HDD feature matrix

Type	Interface	Form Factor	RPM	Sector	Security	Capacity
HDD	12 Gbps SAS	2.5	10K	512n	ISE	600 GB
HDD	12 Gbps SAS	2.5	10K	512n	ISE	1.2 TB
HDD	12 Gbps SAS	2.5	10K	512e	ISE	2.4 TB
HDD	12 Gbps SAS	2.5	10K	512e	FIPS-140	2.4 TB
HDD	12 Gbps SAS	3.5	7.2K	512n	ISE	4 TB
HDD	12 Gbps SAS	3.5	7.2K	512e	ISE	8 TB
HDD	12 Gbps SAS	3.5	7.2K	512e	FIPS-140	8 TB
HDD	12 Gbps SAS	3.5	7.2K	512e	ISE	12 TB
HDD	12 Gbps SAS	3.5	7.2K	512e	ISE	16 TB
HDD	12 Gbps SAS	3.5	7.2K	512e	FIPS-140	16TB
HDD	6 Gbps SATA	3.5	7.2K	512n	ISE	2 TB
HDD	6 Gbps SATA	3.5	7.2K	512n	ISE	4 TB
HDD	6 Gbps SATA	3.5	7.2K	512e	ISE	8 TB

Table 12. HDD feature matrix (continued)

Type	Interface	Form Factor	RPM	Sector	Security	Capacity
HDD	6 Gbps SATA	3.5	7.2K	512e	ISE	12 TB
HDD	6 Gbps SATA	3.5	7.2K	512e	ISE	16 TB

This document is updated as changes happen, so be sure to bookmark it rather than downloading an offline copy to stay with the latest information or see the [Drive and Platform Matrix](#).

HDD Facts

HDD (Hard Disk Drive) is a storage media that are characterized by a set of spinning platters with arms to move recording heads over the surfaces to the right locations for reading and writing designated data.



Figure 5. Hard Disk Drive

The heads read or write the data and transfer it through the interface to the server. That interface for Dell standard enterprise HDDs can be either Serial Attached SCSI (SAS) or Serial ATA (SATA) and affects the speed at which data is transferred. Typically, SATA is 6 gigabits/sec. Where SAS is 12 gigabits/sec so throughput for SAS can be twice that of SATA. Additionally, due to better signal to noise ratios, SAS can have longer cable lengths, allowing it to connect to external data storage. SAS is also considered a more robust protocol.

Enterprise HDDs are typically used with multiple-user servers running enterprise software. Examples are transaction processing databases, internet infrastructure (email, webserver, e-commerce), scientific computing software, and nearline storage management software. Enterprise drives commonly operate continuously ("24/7") in demanding environments while delivering the highest possible performance without sacrificing reliability.

The fastest enterprise HDDs spin at 10,000 RPM and 15,000 RPM, and can achieve sequential media transfer speeds above 290 MB/s. Drives running at 10,000 or 15,000 RPM use smaller platters to mitigate increased power requirements and therefore generally have lower capacity than the highest capacity 7,200 RPM drives. 10 K and 15 K drives are labeled Mission Critical or Performance Optimized, while 7.2 K are called Business Critical or Capacity Optimized. Since 7.2 K drives spin slower, they can have larger platters and space for more platters in an HDD case. That allows for higher capacity drives – 16 TB, 18 TB and so on.

Random read/write task speeds are usually measured in IOPs (Input/Output operations per second) and for 15 K drives can be up to 290. That may sound like a lot but is dwarfed by IOPS (in the hundreds of thousands) available on SSDs. Below is a link to a chart showing HDD performance characteristics:

[HDD_Characteristic_and_Metrics](#)

Depending on the workload type, storage device capabilities are prioritized differently. Below is discussed several capabilities and the media that you would select for each.

- Better performance measured in IOPS: Storage performance for random workloads is measured in IOPS. When ordered in terms of general IOPS performance, choose 15 K, and then 10 K, then 7.2 K and within those SAS HDDs, NL-SAS HDDs, and SATA HDDs.

- Better performance is measured in throughput, or gigabytes per second (GB/s): Unless dealing with heavy sequential workloads that would benefit from flash technology, HDDs are a good choice for most sequential workloads, such as media viewing or database logging. NAND caching can further boost the performance of HDD storage as necessary.
- Lower latency: For workloads sensitive to latency, internal storage on the server itself typically has less latency than storage on external arrays where longer fetch times over the network can greatly add to existing storage latency. It is important to note that SSDs present much lower latency than mechanical HDDs.
- Greater capacity: For capacity-driven workloads, such as email archives, disk-based backup, and object storage applications, high IOPS or throughput performance may be less of a priority as compared to capacity. In this case, choose cost-efficient HDDs, which can offer the greatest capacity at the lowest cost.

While HDDs generally provide lower performance and higher latency than SSDs, they are still an excellent option when used as part of a complete storage strategy that balances cost per GB, capacity, application needs, and performance.

Solid State Drives (SSDs)

SSD Feature Matrix

Table 13. SSD feature matrix

Type	Interface	Speed	Form Factor	Endurance	Security	Capacity	Drive Description
SSD	SAS	24 Gbps	2.5	MU	ISE	1.6 TB	Agnostic SAS MU 1600GB
SSD	SAS	24 Gbps	2.5	MU	ISE	800 GB	Agnostic SAS MU 800GB
SSD	SAS	24 Gbps	2.5	MU	SED FIPS	1.92 TB	Kioxia PM6 FIPS MU 1920GB
SSD	SAS	24 Gbps	2.5	MU	SED FIPS	3.84 TB	Kioxia PM6 FIPS MU 3840GB
SSD	SAS	24 Gbps	2.5	MU	SED FIPS	960 GB	Kioxia PM6 FIPS MU 960GB
SSD	SAS	24 Gbps	2.5	RI	ISE	1.92 TB	Agnostic SAS RI 1920GB
SSD	SAS	24 Gbps	2.5	RI	ISE	3.84 TB	Agnostic SAS RI 3840GB
SSD	SAS	24 Gbps	2.5	RI	ISE	7.68 TB	Agnostic SAS RI 7680GB
SSD	SAS	24 Gbps	2.5	RI	SED FIPS	1.92 TB	Kioxia PM6 FIPS RI 1920GB
SSD	SAS	24 Gbps	2.5	RI	SED FIPS	3.84 TB	Kioxia PM6 FIPS RI 3840GB
SSD	SAS	24 Gbps	2.5	RI	SED FIPS	7.68 TB	Kioxia PM6 FIPS RI 7680GB
SSD	SATA	6 Gbps	2.5	MU	ISE	1.92 TB	Agnostic SATA MU 1920GB
SSD	SATA	6 Gbps	2.5	MU	ISE	480 GB	Agnostic SATA MU 480GB
SSD	SATA	6 Gbps	2.5	MU	ISE	960 GB	Agnostic SATA MU 960GB
SSD	SATA	6 Gbps	2.5	MU	ISE	3.84 TB	Agnostic SATA MU 3840GB
SSD	SATA	6 Gbps	2.5	RI	ISE	1.92 TB	Agnostic SATA RI 1920GB
SSD	SATA	6 Gbps	2.5	RI	ISE	3.84 TB	Agnostic SATA RI 3840GB
SSD	SATA	6 Gbps	2.5	RI	ISE	480 GB	Agnostic SATA RI 480GB
SSD	SATA	6 Gbps	2.5	RI	ISE	960 GB	Agnostic SATA RI 960GB
SSD	vSAS	12 Gbps	2.5	MU	SED	1.92 TB	Agnostic Value SAS SED MU 1920GB
SSD	vSAS	12 Gbps	2.5	MU	SED	3.84 TB	Agnostic Value SAS SED MU 3840GB
SSD	vSAS	12 Gbps	2.5	MU	SED	960 GB	Agnostic Value SAS SED MU 960GB
SSD	vSAS	12 Gbps	2.5	RI	SED	1.92 TB	Agnostic Value SAS SED RI 1920GB
SSD	vSAS	12 Gbps	2.5	RI	SED	7.68 TB	Agnostic Value SAS SED RI 7680GB

Table 13. SSD feature matrix (continued)

Type	Interface	Speed	Form Factor	Endurance	Security	Capacity	Drive Description
SSD	vSAS	12 Gbps	2.5	RI	SED	960 GB	Agnostic Value SAS SED RI 960GB
SSD	NVMe	Gen4	U.2	MU	ISE	800 GB	Agnostic
SSD	NVMe	Gen4	U.2	RI	ISE	960 GB	Agnostic
SSD	NVMe	Gen4	U.2	MU	ISE	1.6 TB	Agnostic
SSD	NVMe	Gen4	U.2	RI	ISE	1.92 TB	Agnostic
SSD	NVMe	Gen4	U.2	MU	ISE	3.2 TB	Agnostic
SSD	NVMe	Gen4	U.2	RI	ISE	3.84 TB	Agnostic
SSD	NVMe	Gen4	U.2	RI	ISE	7.68 TB	Agnostic

This document is updated as changes happen, so be sure to bookmark it rather than downloading an offline copy to stay with the latest information or see the [Drive and Platform Matrix](#).

SSD Facts

Unlike hard disk drives (HDDs) which use a spinning platter to store data, solid state drives (SSDs) use solid state memory NAND flash. HDDs have several different mechanical moving parts which make them susceptible to vibrational and handling interference. Solid state drives, on the other hand have no moving parts and are therefore much less susceptible to vibrational or handling damage even when impacted during use.

SSDs deliver high-performance input/output operations per second (IOPS), and very low latency for transaction - intensive server and storage applications. Properly used in systems with HDDs, they reduce total cost of ownership (TCO) through low power consumption and low operating temperature.

Dell offers different solid-state drive (SSD) solutions to meet different customer needs. Enterprise SSDs, as a class, are unique compared to client or consumer-based SSD in terms of reliability, performance and architecture. While consumer-based SSDs, such as those utilized in notebooks are designed with a focus on consumer-based workloads, rigidity and battery life, enterprise-class SSDs are designed around enterprise application I/O (input/output) requirements with focus points of random I/O performance, reliability, and protection of data during a sudden power-down.

Understanding the basics of enterprise-class SSDs allow customers to make informed decisions when comparing solutions:

- **Over-provisioning:** The Achilles' heel of SSDs are their write characteristics. To rewrite an area of an SSD that has already been written, the data must be erased and then written. In order to overcome a portion of the write performance penalty, Dell enterprise SSDs found across Dell PowerEdge products, all employ a practice that is known as over-provisioning of Flash. This practice keeps native Flash capacity beyond the user-defined capacity and uses the additional space as a scratch pad of sorts to quickly put down application write data on areas of Flash that are already in an erased state. The SSDs perform cleanup functions of this over-provisioned Flash space during time periods typically not impacting application performance.
- **Write Endurance:** Write endurance is the number of program/erase (P/E or write cycles) that can be applied to a block of flash memory before the storage media becomes unreliable. Due to different data center workloads and read/write needs, Dell offers different enterprise SSDs with different endurance ratings so customers can design the right solution for their needs.

Below are the different categories (swim lanes) of enterprise SSDs Dell offers:

- **Mixed Use (MU, 3 WPD):** 70/30 read/write workloads with medium endurance. E-mail/messaging, OLTP, and E-commerce are example workloads.
- **Read Intensive (RI, 1 WPD):** 90/10 read/write workloads with lower endurance. Database warehousing, media streaming, and VOD solutions are example workloads.

Dell enterprise SSDs support five kinds of host interface options:

- **NVMe SSD:** NVMe SSDs are a mainstream, high-performance, high reliability solid-state storage device that enables IOPS performance of up to 2000x more than conventional rotating hard drives.
- **Datacenter NVMe:** datacenter NVMe SSDs share the same value proposition as NVMe SSDs, but with a reduction in cost at only a minor performance tradeoff as compared to NVMe.
- **SAS SSD:** SAS SSDs are based on the industry standard SAS interface. SAS SSDs combine superior reliability, data integrity, and data fail recovery making them suitable for enterprise applications.

- Value SAS: Value SAS is a new class of SAS SSD that leverages the PowerEdge SAS server infrastructure to deliver SAS like performance at a cost that is competitive with SATA.
- SATA SSD: SATA SSDs are based on the industry standard SATA interface. SATA SSDs provide reasonable performance for enterprise servers.

Dell Enterprise SSDs will support a new form factor in addition to several existing:

- E3.S: Part of the EDSFF family, E3.S is targeted to NVMe SSDs with x4 PCIe link widths though it can mechanically fit an x16 card edge. It supports power profiles up to 25 W and positioned to be a primary form factor for mainstream NVMe server storage subsystems as it can be used across a wide variety of platforms including modular and short depth chassis.

Internal storage configuration

PowerEdge R360 supports the following internal storage configurations:

- 8 x 2.5 inch SAS/SATA RAID
- 4 x 3.5 inch SAS/SATA RAID
- 6 x 2.5-inch hot-swappable SAS/SATA drives through PERC + 2 x 2.5-inch direct attach NVMe

 **NOTE:** The PowerEdge R360 system does not support rear storage.

External Storage

The PowerEdge R360 supports the external storage device types that are listed in the table below.

Table 14. Supported External Storage Devices

Device Type	Description
External Tape	Supports connection to external USB tape products
NAS/IDM appliance software	Supports NAS software stack
JBOD	Supports connection to 12 Gb MD-series JBODs

Networking

Topics:

- [Supported network cards](#)
- [Overview](#)

Supported network cards

Table 15. Supported network cards

Vendor	Port type	Port speed	Port count
Broadcom	F1	1 GbE	4
Intel	BT	10 GbE	2
Intel	BT	10 GbE	4
Broadcom	BT	10 GbE	3
Broadcom	BT	10 GbE	4
Intel	F1	1 GbE	4

Overview

PowerEdge offers a wide variety of options to get information moving to and from our servers. Industry best technologies are chosen, and systems management features are added by our partners to firmware to tie in with iDRAC. These adapters are rigorously validated for worry-free, fully supported use in Dell servers.

PCIe subsystem

Topics:

- [PCIe risers](#)

PCIe risers

The PowerEdge R360 system supports a Gen4 butterfly riser on the system.

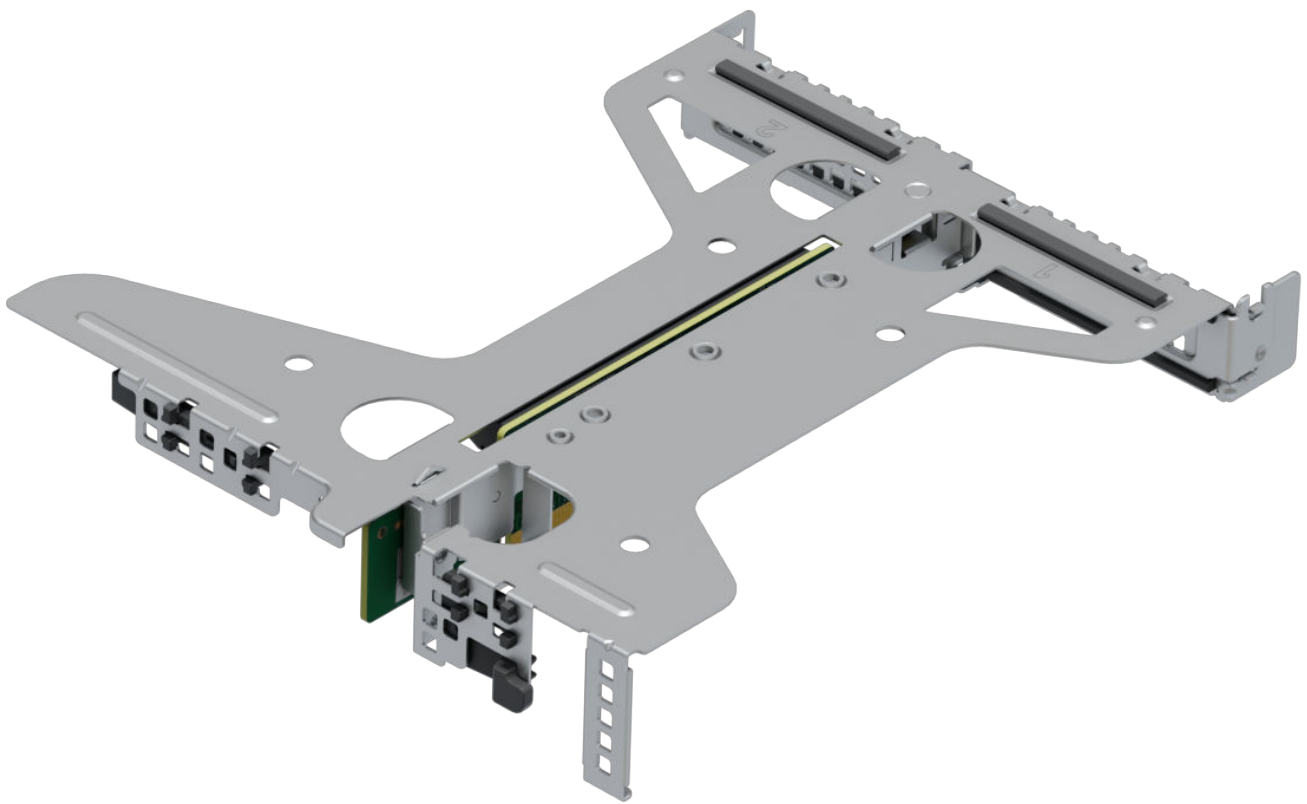

Figure 6. Butterfly Riser

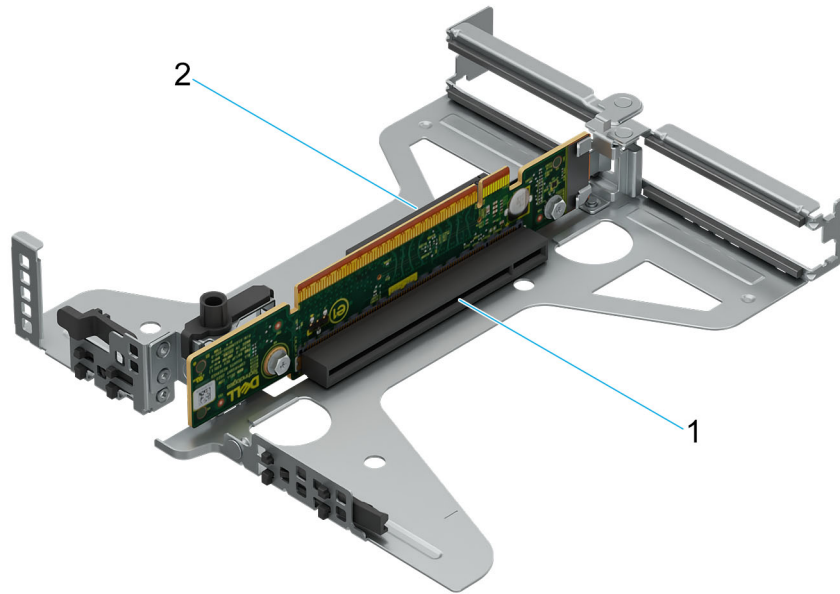

Figure 7. Butterfly Riser

- 1. PCIe Slot 2
- 2. PCIe Slot 1

Table 16. PCIe riser configurations

Configuration No.	Riser Configuration	No. of Processors	PERC type supported (internal slot)	Rear Storage Possible
RC0	1x PERC - No Riser	1	aPERC or fPERC	No
RC2	1x PERC + 1x Riser (Gen4)	1	aPERC or fPERC	No

Power, thermal, and acoustics

PowerEdge servers have an extensive collection of sensors that automatically track thermal activity, which helps to regulate temperature by reducing server noise and power consumption. The table below lists the tools and technologies Dell offers to lower power consumption and increase energy efficiency.

Topics:

- [Power](#)
- [Thermal](#)
- [Acoustics](#)

Power

Table 17. Power tools and technologies

Feature	Description
Power Supply Units(PSU) portfolio	Dell's PSU portfolio includes intelligent features such as dynamically optimizing efficiency while maintaining availability and redundancy. Find additional information in the Power supply units section.
Tools for right sizing	Enterprise Infrastructure Planning Tool (EIPT) is a tool that can help you determine the most efficient configuration possible. With Dell's EIPT, you can calculate the power consumption of your hardware, power infrastructure, and storage at a given workload. Learn more at Dell EIPT .
Industry Compliance	Dell's servers are compliant with all relevant industry certifications and guide lines, including 80 PLUS, Climate Savers and ENERGY STAR.
Power monitoring accuracy	PSU power monitoring improvements include: <ul style="list-style-type: none"> • Dell's power monitoring accuracy is currently 1%, whereas the industry standard is 5% • More accurate reporting of power • Better performance under a power cap
Power capping	Use Dell's systems management to set the power cap limit for your systems to limit the output of a PSU and reduce system power consumption. Dell is the first hardware vendor to leverage Intel Node Manager for circuit-breaker fast capping.
Systems Management	iDRAC Enterprise and Datacenter provides server-level management that monitors, reports and controls power consumption at the processor, memory and system level. Dell OpenManage Power Center delivers group power management at the rack, row, and data center level for servers, power distribution units, and uninterruptible power supplies.
Active power management	Intel Node Manager is an embedded technology that provides individual server-level power reporting and power limiting functionality. Dell offers a complete power management solution comprised of Intel Node Manager accessed through Dell iDRAC9 Datacenter and OpenManage Power Center that allows policy-based management of power and thermal at the individual server, rack, and data center level. Hot spare reduces power consumption of redundant power supplies. Thermal control off a speed optimizes the thermal settings for your environment to reduce fan consumption and lower system power consumption. Idle power enables Dell servers to run as efficiently when idle as when at full workload.
Rack infrastructure	Dell offers some of the industry's highest-efficiency power infrastructure solutions, including:

Table 17. Power tools and technologies (continued)

Feature	Description
	<ul style="list-style-type: none"> • Power distribution units (PDUs) • Uninterruptible power supplies (UPSs) • Energy Smart containment rack enclosures Find additional information at: Power and Cooling .

Power Supply Units

Energy Smart power supplies have intelligent features, such as the ability to dynamically optimize efficiency while maintaining availability and redundancy. Also featured are enhanced power-consumption reduction technologies, such as high-efficiency power conversion and advanced thermal-management techniques, and embedded power-management features, including high-accuracy power monitoring. The table below shows the power supply unit options that are available for the PowerEdge R360.

Table 18. Power Supply Unit Options

Wattage	Frequency	Voltage/Current	Class	Heat dissipation
600 W	50/60 Hz	100-240 Vac/7.1 - 3.6 A	Platinum	2250 BTU/hr
	NA	240 Vdc/2.9 A	NA	
700 W	50/60 Hz	200-240 Vac/4.1 A	Titanium	2625 BTU/hr
	NA	240 Vdc/3.4 A	NA	

NOTE: If a system with AC 1100W or 1400W PSUs operate at low line 100 ~ 120 Vac, then the power rating per PSU is de-rated to 1050W.

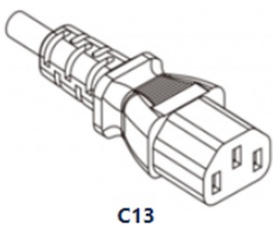

Figure 8. PSU power cord

Table 19. PSU power cords

Form factor	Output	Power cord
Redundant 60 mm	600 W	C13 /C14 (inlet)
	700 W	

Thermal

PowerEdge servers have an extensive collection of sensors that automatically track thermal activity, which helps regulate temperature thereby reducing server noise and power consumption.

Thermal design

Thermal management of the platform helps deliver high performance with the right amount of cooling to components, while maintaining the lowest fan speeds possible. This is done across a wide range of ambient temperatures from 10°C to 35°C (50°F to 95°F) and to extended ambient temperature ranges.

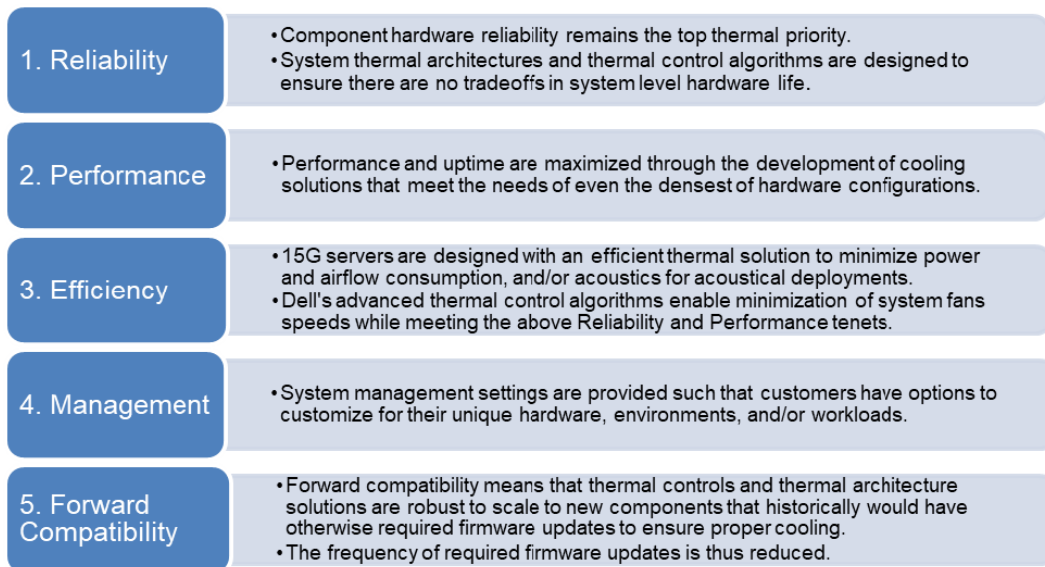

Figure 9. Thermal design characteristics

The thermal design of the PowerEdge R360 reflects the following:

- Optimized thermal design: The system layout is architected for optimum thermal design.
- System component placement and layout are designed to provide maximum airflow coverage to critical components with minimum expense of fan power.
- Comprehensive thermal management: The thermal control system regulates the fan speed based on several different responses from all system-component temperature sensors, as well as inventory for system configurations. Temperature monitoring includes components such as processors, DIMMs, chipset, the inlet air ambient, hard disk drives, and OCP.
- Open and closed loop thermal fan speed control: Open loop thermal control uses system configuration to determine fan speed based on inlet air ambient temperature. Closed loop thermal control method uses feedback temperatures to dynamically determine proper fan speeds.
- User-configurable settings: With the understanding and realization that every customer has unique set of circumstances or expectations from the system, in this generation of servers, we have introduced limited user-configurable settings residing in the iDRAC BIOS setup screen. For more information, see the Dell PowerEdge R360 Installation and Service Manual at [PowerEdge Manuals](#) and “Advanced Thermal Control: Optimizing across Environments and Power Goals” on Dell.com.
- Cooling redundancy: The PowerEdge R360 allows N+1 fan redundancy, allowing continuous operation with one fan failure in the system.
- Environmental Specifications: The optimized thermal management makes the PowerEdge R360 reliable under a wide range of operating environments.

Acoustics

Acoustical performance

Dell PowerEdge R360 is a rack server appropriate for general use space or datacenter environment.

Table 20. Hardware and software configurations for lower acoustical output

Configuration	Quietest	Volume	Volume with BOSS	Feature Rich with GPU	Feature Rich with max storage
Processor	Xeon E-2400/ Xeon 6300 series, 65 W	Xeon E-2400/ Xeon 6300 series, 65 W	Xeon E-2400/Xeon 6300 series, 65 W	Xeon E-2400/ Xeon 6300 series, 95 W	Xeon E-2400/ Xeon 6300 series, 95 W
Processor Quantity	1	1	1	1	1
RDIMM Memory	16 GB DDR5 UDIMM	16 GB DDR5 UDIMM	16 GB DDR5 UDIMM	32 GB DDR5 UDIMM	32 GB DDR5 UDIMM
Memory Quantity	1	2	2	4	4
Backplane Type	4 x 3.5-inch BP	4 x 3.5-inch BP	4 x 3.5-inch BP	8 x 2.5 inch BP	8 x 2.5 inch BP
HDD Type	3.5 inch SATA 2 TB HDD	3.5 inch SATA 2 TB HDD	3.5 inch SATA 2 TB HDD	2.5 inch SAS 600 GB HDD	2.5 inch SAS 600 GB HDD
HDD Quantity	2	2	2	8	8
PSU Type	600 W (60 mm)	600 W (60 mm)	600 W (60 mm)	600 W (60 mm)	600 W (60 mm)
PSU Quantity	2	2	2	2	2
PCIe Card	PERC H355	PERC H355	PERC H355	PERC H755 2x 1 GbE NIC A2 GPU (60 W)	PERC H755 2x 1 GbE NIC
Bezel	N/A	Yes	Yes	Yes	Yes
BOSS	N/A	N/A	Yes	N/A	N/A

Table 21. Acoustical performance of R360 acoustical configurations

Configuration	Quietest	Volume	Volume with BOSS	Feature Rich with GPU	Feature Rich with max storage
Acoustical Performance: Idle/ Operating @ 25 °C Ambient					
L _{WA,m} (B)	Idle	5.1	5.1	5.5	5.7
	Operating	5.1	5.1	5.5	8.0
K _v (B)	Idle	0.4	0.4	0.4	0.4
	Operating	0.4	0.4	0.4	0.4
L _{pA,m} (dB)	Idle	35	35	39	40
	Operating	35	35	39	65
Prominent tones	No prominent tones in Idle and Operating				
Acoustical Performance: Idle @ 28 °C Ambient					
L _{WA,m} (B)	5.9	5.9	5.9	6.0	5.9
K _v (B)	0.4	0.4	0.4	0.4	0.4

Table 21. Acoustical performance of R360 acoustical configurations (continued)

Configuration	Quietest	Volume	Volume with BOSS	Feature Rich with GPU	Feature Rich with max storage
L _{pA,m} (dB)	43	43	43	44	44
Acoustical Performance: Max. Loading @ 35 °C Ambient					
L _{wA,m} (B)	7.1	5.9	5.9	8.0	7.7
K _v (B)	0.4	0.4	0.4	0.4	0.4
L _{pA,m} (dB)	53	53	53	65	62

L_{wA,m}: The declared mean A-weighted sound power level (L_{wA}) is calculated per section 5.2 of ISO 9296 (2017) with data collected using the methods described in ISO 7779 (2010). Data presented here may not be fully compliant with ISO 7779.

L_{pA,m}: The declared mean A-weighted emission sound pressure level is at the bystander position per section 5.3 of ISO 9296 (2017) and measured using methods described in ISO 7779 (2010). The system is placed in a 24U rack enclosure, 25 cm above a reflective floor. Data presented here may not be fully compliant with ISO 7779.

Prominent tones: Criteria of D.6 and D.11 of ECMA-74 (17th ed., Dec. 2019) are followed to determine if discrete tones are prominent and to report them, if so.

Idle mode: The steady-state condition in which the server is energized but not operating any intended function.

Operating mode: The maximum of the steady state acoustical output at 50% of CPU TDP or active HDDs per C.9.3.2 in ECMA-74 (17th ed., Dec. 2019)

Power Capping

The PowerEdge R360 supports the NVIDIA A2 GPU, which provides enterprise-level performance, therefore, louder acoustic performance is expected. Power capping solutions provides better acoustic performance by limiting GPU performance by up to 20%.

Table 22. Acoustical performance of R360 on power capping

R360	Without Power Capping	With Power Capping
Acoustic Performance	8.0 bels	6.3 bels
Acoustic Category	Category 6	Category 4

 **NOTE:** PowerEdge R360 with GPU workload is not recommend for an acoustically sensitive environment.

Rack, rails, and cable management

Topics:

- [Rack Rails](#)

Rack Rails

The rail offerings for the PowerEdge R360 consist of two types — sliding and static. The sliding and static rail systems for the PowerEdge R360 provide tool-less support for four-post racks with tooled installation for square, round or threaded holes including all generations of Dell racks. Both also support tooled mounting in four-post threaded racks, and the static rails support tooled mounting in two-post (Telco) racks as well for added versatility.

The sliding rails for the PowerEdge R360 offer native support for threaded hole racks via the ReadyRails™ II mounting interface. The rails ship in the tool-less mounting configuration, but can be converted to the tooled configuration very quickly and easily as shown in the figure below.

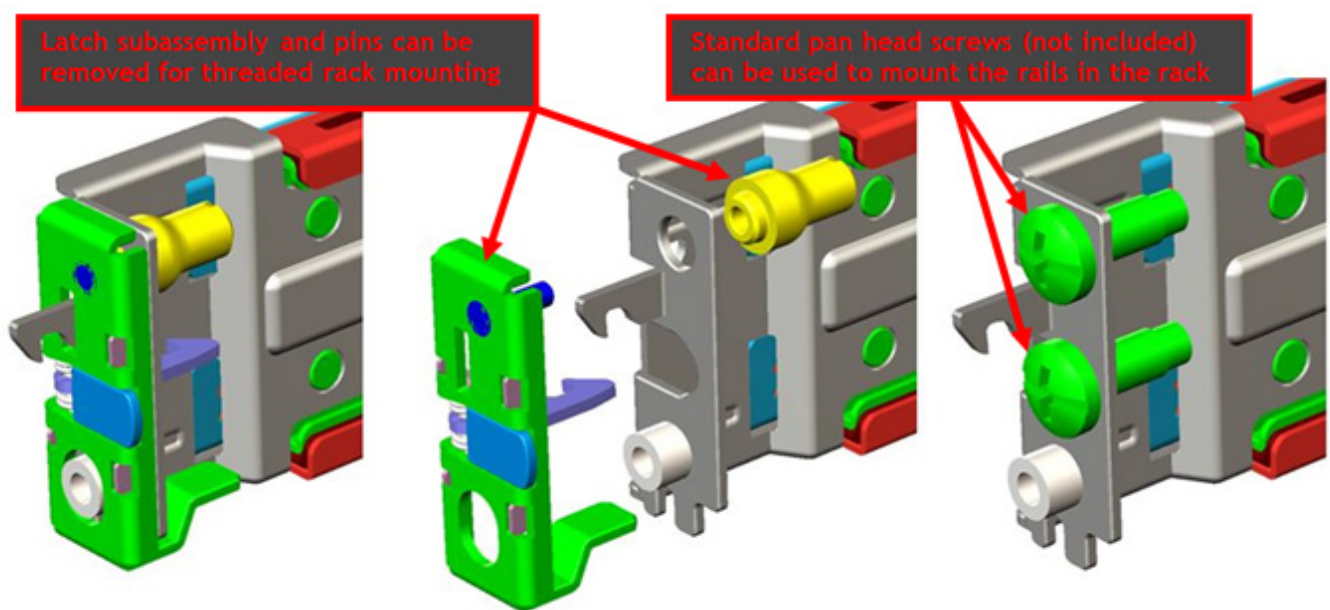

Figure 10. ReadyRails II Mounting Interface

One key factor in selecting the proper rails is identifying the type of rack in which they will be installed. Both the sliding rails and the static rails support tool-less mounting in 19-inch wide, EIA-310-E compliant square hole and unthreaded round hole four-post racks. Both also support tooled mounting in threaded hole four-post racks, but only the static rails, as the more “universal” solution, support mounting in two-post (Telco) racks.

Table 23. Sliding and static rail configurations

Sliding and Static Rail								
Product	Rail Identifier	Mounting Interface	Rail Type	Rack Types Supported				
				4-Post			2-Post	
				Square	Round	Thread	Flush	Center
PowerEdge R360	A12	ReadyRails II	Sliding	√	√	√ ¹	X	X
	A8	ReadyRails	Static	√	√	√ ¹	√ ¹	√ ¹

¹ Minor conversion required.

Note that screws are not included in either kit due to the fact that threaded racks are offered with a variety of thread designations. Users must therefore provide their own screws when mounting the rails in threaded racks.

NOTE: Screw head diameter for the sliding rails must be 10 mm or less.

Other key factors governing proper rail selection include the spacing between the front and rear mounting flanges of the rack, the type and location of any equipment mounted in the back of the rack such as power distribution units (PDUs), and the overall depth of the rack. The static rails offer a greater adjustability range and a smaller overall mounting footprint than the sliding rails. This is because of their reduced complexity and lack of need for CMA support.

Table 24. Rail adjustable range and rail depth specifications

Rail Adjustable Range and Rail Depth											
Product	Rail Identifier	Chassis configuration	Rail Type	Rail Adjustable Range (mm)						Rail Depth (mm)	
				Square*		Round*		Threaded*		without CMA	with CMA
				Min	Max	Min	Max	Min	Max		
PowerEdge R360	A12	2.5-inch	Sliding	631	868	617	861	631	883	720	845
		3.5-inch	Sliding	681	868	667	861	681	883	770	895
	A8	Static	608	879	594	872	618	898	622	-	

* Values represent the distance between the front and rear mounting flanges on the rack.

NOTE: The adjustment range of the rails is a function of the type of rack in which they are being mounted. The Min/Max values listed above represent the allowable distance between the front and rear mounting flanges in the rack. Rail depth without the CMA represents the minimum depth of the rail with the outer CMA brackets removed (if applicable) as measured from the front mounting flanges of the rack.

NOTE: 3.5 inch HDD configurations utilize a self-adjusting slide feature. To fully install the system, this feature requires extra force during the last 50 mm travel.

Ready Rails II Sliding Rails for 4-Post Racks

- Support for tool-less installation in 19" EIA-310-E compliant square or unthreaded round hole four-post racks including all generations of Dell racks.
- Support for tooled installation in 19-inch EIA-310-E compliant threaded hole four-post racks.
- Support full extension of the system out of the rack to allow serviceability of key internal components.
- Support for optional cable management arm (CMA).
- Minimum rail mounting depth without the CMA (2.5-inch configuration): 720 mm
- Minimum rail mounting depth without the CMA (3.5-inch configuration): 770 mm
- Minimum rail mounting depth with the CMA (2.5-inch configuration): 845 mm
- Minimum rail mounting depth with the CMA (3.5-inch configuration): 895 mm
- Square-hole rack adjustment range (2.5-inch configuration): 631-868 mm
- Square-hole rack adjustment range (3.5-inch configuration): 681-868 mm
- Round-hole rack adjustment range (2.5-inch configuration): 617-861 mm
- Round-hole rack adjustment range (3.5-inch configuration): 667-861 mm

- Threaded-hole rack adjustment range (2.5-inch configuration): 631-883 mm
- Threaded-hole rack adjustment range (3.5-inch configuration): 681-883 mm

The sliding rails allow the system to be fully extended out of the rack for service. They are available with or without the optional cable management arm (CMA).

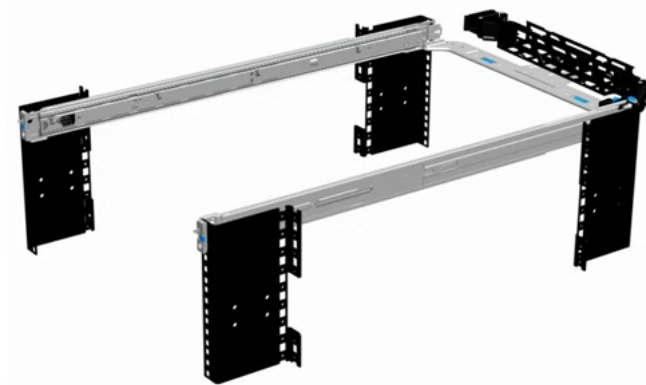

Figure 11. Sliding rails with optional CMA

Ready Rails Static Rails for 4-Post and 2-Post Racks

- Support tool-less installation in 19-inch EIA-310-E compliant square or unthreaded round hole four-post racks including all generations of Dell racks.
- Support tooled installation in 19-inch EIA-310-E compliant threaded hole four-post and two-post racks.
- Minimum rail mounting depth: 622 mm
- Square-hole rack adjustment range: 608-879 mm
- Round-hole rack adjustment range: 594-872 mm
- Threaded-hole rack adjustment range: 618-898 mm

The static rails support a wider variety of racks than the sliding rails. However, they do not support serviceability in the rack and are thus not compatible with the CMA.

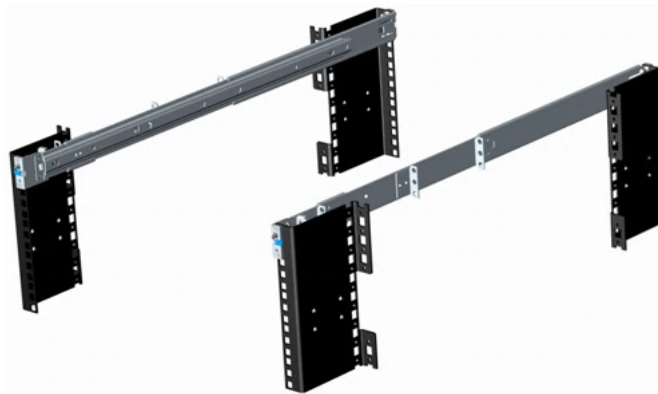

Figure 12. Static rails

Cable Management Arm (CMA)

The optional cable management arm (CMA) for the PowerEdge R360 organizes and secures the cords and cables exiting the back of the server. It unfolds to allow the server to extend out of the rack without having to detach the cables. Some key features of the PowerEdge R360 CMA include:

- Large U-shaped baskets to support dense cable loads.
- Open vent pattern for optimal airflow.
- Ability to be mounted on either side by simply swinging the spring-loaded brackets from one side to the other.
- Utilizes hook-and-loop straps rather than plastic tie wraps to eliminate the risk of cable damage during cycling.
- Includes a low-profile fixed tray to both support and retain the CMA in its fully closed position.

- Both the CMA and the tray mount without the use of tools via simple and intuitive snap-in designs.

The CMA can be mounted to either side of the sliding rails without the use of tools or the need for conversion. However, it is recommended that it be mounted on the side opposite to the power supplies to allow easier access to the power supplies and rear hard drives (if applicable) for service or replacement.



Figure 13. System mounted in sliding rails with the CMA

The PowerEdge R360 static rails are a "stab-in" design. This means that the inner (chassis) rail members must first be attached to the sides of the system and then inserted into the outer (cabinet) members installed in the rack.



Figure 14. System mounted in static rails in two-post center-mount configuration

Rack Installation

The PowerEdge R360 sliding rails are a "drop-in" design. This means that the system is installed vertically into the rails by inserting the standoffs on the sides of the system into the "J-slots" in the inner rail members with the rails in the fully extended position. The recommended method of installation is to first insert the rear standoffs on the system into the rear J-slots on the rails in order to free up a hand and then rotate the system down into the remaining J-slots while using the free hand to hold the rail against the side of the system.

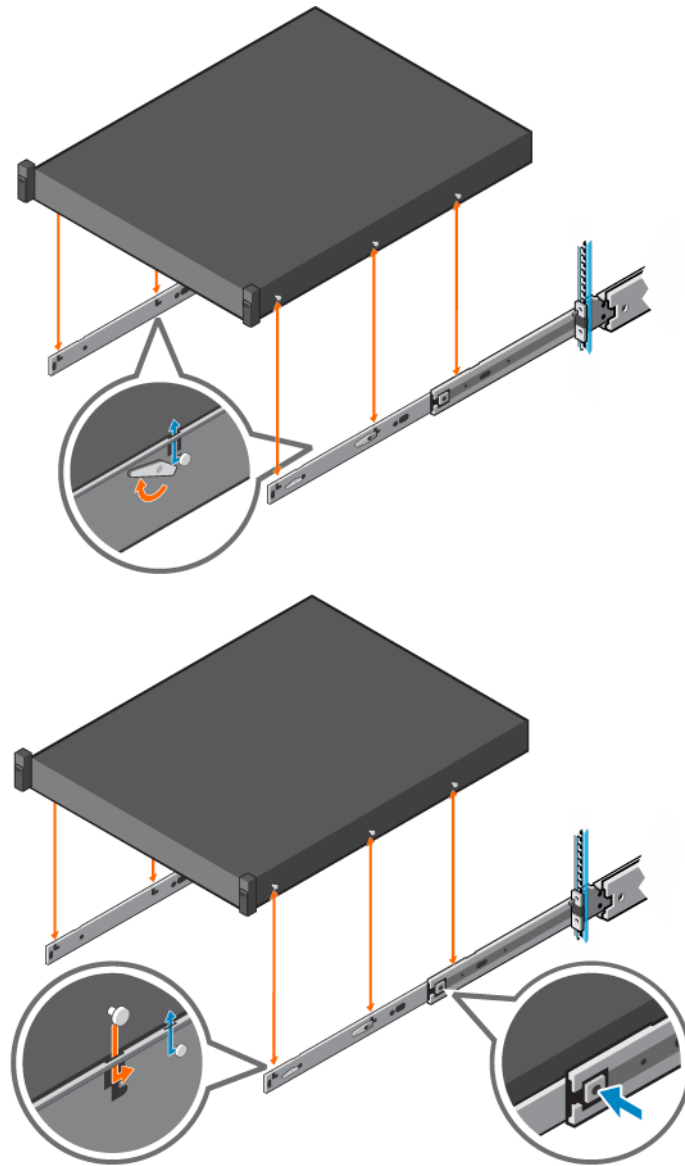

Figure 15. Sliding rails

Installing Systems in Sliding Rails

To install the system in sliding rails:

1. Pull the inner slide rails out of the rack until they lock into place.
 - Hold the system by its front and back ends and tilt the front end upward slightly.
 - Check the window on the sides of both rails to confirm that the heads of the standoffs are visible before adjusting or releasing your grip on the back end of the system.
 - Use your free hand to hold the rail against the side of the chassis if needed as the system is rotated downward into the remaining J-slots.
2. Locate the rear rail standoff on each side of the system and lower them into the rear J-slots of the slide assembly.
3. Rotate the system downward until all the rail standoffs are seated in the J-slots.
4. Push the system inward until the lock levers click into place. Press the slide-release lock buttons on both rails and slide the system into the rack.

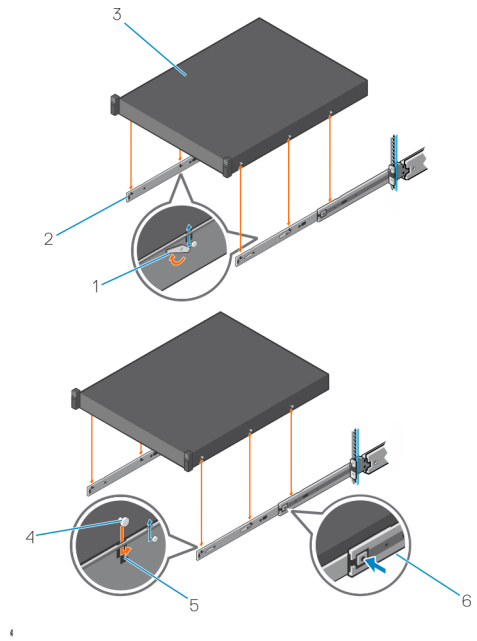

Figure 16. Sliding rails installation

- | | |
|--------------------------|---------------------------------|
| 1. Server-lock latch (2) | 2. inner slide rail (2) |
| 3. system | 4. standoff on the system |
| 5. J-slot on the rail | 6. slide-release lock latch (2) |

Operating Systems and Virtualization

Topics:

- [Supported Operating Systems](#)

Supported Operating Systems

The PowerEdge system supports the following operating systems:

- Canonical® Ubuntu® Server LTS
- Microsoft® Windows Server® with Hyper-V
- Red Hat® Enterprise Linux
- SUSE® Linux Enterprise server
- VMware® ESXi®
- Dell NativeEdge

Links to specific operating system versions and editions, certification matrices, Hardware Compatibility Lists (HCL) portal, and Hypervisor support are available at [Dell Enterprise Operating Systems](#).

 **NOTE:** Intel Xeon® 6300 series CPUs do not support Windows Server 2019.

Dell Systems Management

Dell delivers management solutions that help IT administrators effectively deploy, update, monitor, and manage IT assets. Dell solutions and tools enable you to quickly respond to problems by helping them to manage Dell servers efficiently; in physical, virtual, local, and remote environments; all without the need to install an agent in the operating system.

The OpenManage portfolio includes:

- Innovative embedded management tools - integrated Dell Remote Access Controller (iDRAC)
- Consoles - OpenManage Enterprise
- Extensible with plug-ins - OpenManage Power Manager
- Update tools - Repository Manager

Dell has developed comprehensive systems management solutions that are based on open standards and has integrated with management consoles from partners such as Microsoft and VMware, allowing advanced management of Dell servers. Dell management capabilities extend to offerings from the industry's top systems management vendors and frameworks such as Ansible, Splunk, and ServiceNow. OpenManage tools automate the full span of server life cycle management activities along with powerful RESTful APIs to script or integrate with your choice of frameworks.

For more information about the entire OpenManage portfolio, see:

- The latest [Dell Systems Management Overview Guide](#).

Topics:

- [Integrated Dell Remote Access Controller \(iDRAC\)](#)
- [Systems Management software support matrix](#)

Integrated Dell Remote Access Controller (iDRAC)

iDRAC9 delivers advanced, agent-free, local and remote server administration. Embedded in every PowerEdge server, iDRAC9 provides a secure means to automate a multitude of common management tasks. Because iDRAC is embedded within every PowerEdge server, there is no additional software to install; just plug in power and network cables, and iDRAC is ready to go. Even before installing an operating system (operating system) or hypervisor, IT administrators have a complete set of server management features at their fingertips.

With iDRAC9 in-place across the Dell PowerEdge portfolio, the same IT administration techniques and tools can be applied throughout. This consistent management platform allows easy scaling of PowerEdge servers as an organization's infrastructure grows. Customers can use the iDRAC RESTful API for the latest in scalable administration methods of PowerEdge servers. With this API, iDRAC enables support for the Redfish standard and enhances it with Dell extensions to optimize at-scale management of PowerEdge servers. By having iDRAC at the core, the entire OpenManage portfolio of Systems Management tools allows every customer to tailor an effective, affordable solution for any size environment.

Zero Touch Provisioning (ZTP) is embedded in iDRAC. ZTP - Zero Touch Provisioning is Intelligent Automation Dell's agent-free management puts IT administrators in control. Once a PowerEdge server is connected to power and networking, that system can be monitored and fully managed, whether you're standing in front of the server or remotely over a network. In fact, with no need for software agents, an IT administrator can: · Monitor · Manage · Update · Troubleshoot and remediate Dell servers. With features like zero-touch deployment and provisioning, iDRAC Group Manager, and System Lockdown, iDRAC9 is purpose-built to make server administration quick and easy. For those customers whose existing management platform utilizes in-band management, Dell does provide iDRAC Service Module, a lightweight service that can interact with both iDRAC9 and the host operating system to support legacy management platforms.

When ordered with DHCP enabled from the factory, PowerEdge servers can be automatically configured when they are initially powered up and connected to your network. This process uses profile-based configurations that ensure each server is configured per your specifications. This feature requires an iDRAC Enterprise license.

iDRAC9 offers following license tiers:

Table 25. iDRAC9 license tiers

License	Description
iDRAC9 Basic	<ul style="list-style-type: none"> Available only on 100-500 series rack/tower Basic instrumentation with iDRAC web UI For cost conscious customers that see limited value in management
iDRAC9 Express	<ul style="list-style-type: none"> Default on 600+ series rack/tower, modular, and XR series Includes all features of Basic Expanded remote management and server life-cycle features
iDRAC9 Enterprise	<ul style="list-style-type: none"> Available as an upsell on all servers Includes all features of Basic and Express. Includes key features such as virtual console, AD/LDAP support, and more Remote presence features with advanced, Enterprise-class, management capabilities
iDRAC9 Datacenter	<ul style="list-style-type: none"> Available as an upsell on all servers Includes all features of Basic, Express, and Enterprise. Includes key features such as telemetry streaming, Thermal Manage, automated certificate management, and more Extended remote insight into server details, focused on high end server options, granular power, and thermal management

For a full list of iDRAC features by license tier, see [Integrated Dell Remote Access Controller 9 User's Guide](#) at [Dell.com](#).

For more details on iDRAC9 including white papers and videos, see:

- [Support for Integrated Dell Remote Access Controller 9 \(iDRAC9\)](#) on the [Knowledge Base](#) page at [Dell.com](#)

Systems Management software support matrix

Table 26. Systems Management software support matrix

Categories	Features	PE mainstream
Embedded Management and In-band Services	iDRAC9 (Express, Enterprise, and Datacenter licenses)	Supported
	OpenManage Mobile	Supported
	OM Server Administrator (OMSA)	Supported
	iDRAC Service Module (iSM)	Supported
	Driver Pack	Supported
Change Management	Update Tools (Repository Manager, DSU, Catalogs)	Supported
	Server Update Utility	Supported
	Lifecycle Controller Driver Pack	Supported
	Bootable ISO	Supported
Console and Plug-ins	OpenManage Enterprise	Supported
	Power Manager Plug-in	Supported
	Update Manager Plug-in	Supported
	SupportAssist Plug-in	Supported
	CloudIQ	Supported
Integrations and connections	OM Integration with VMware Vcenter/vROps	Supported
	OM Integration with Microsoft System Center (OMIMSC)	Supported
	Integrations with Microsoft System Center and Windows Admin Center (WAC)	Supported

Table 26. Systems Management software support matrix (continued)

Categories	Features	PE mainstream
	ServiceNow	Supported
	Ansible	Supported
	Third-party Connectors (Nagios, Tivoli, Microfocus)	Supported
Security	Secure Enterprise Key Management	Supported
	Secure Component Verification	Supported
Standard operating system	Red Hat Enterprise Linux, SUSE, Windows Server 2019 or 2022, Ubuntu, CentOS	Supported (Tier-1)

Appendix D: Service and support

Topics:

- [Why attach service contracts](#)
- [ProSupport Infrastructure Suite](#)
- [Specialty Support Services](#)
- [ProDeploy Infrastructure Suite](#)
- [Supplemental Deployment Services](#)
- [Unique Deployment Scenarios](#)
- [DAY 2 – Automation Services with Ansible](#)
- [Dell Technologies Consulting Services](#)

Why attach service contracts

Dell PowerEdge servers include a standard hardware warranty that highlights our commitment to product quality by guaranteeing repair or replacement of defective components. While industry-leading, our warranties are limited to 1 or 3 years, depending on model, and do not cover software assistance. Call records show that customers are most often seeking Dell technical support for software related issues like configuration guidance, troubleshooting, upgrade assistance or performance tuning. Encourage customers to purchase ProSupport service contracts to supplement warranty coverage and ensure optimal support for both hardware and software. ProSupport provides a complete hardware guarantee beyond the original warranty period.

ProSupport Infrastructure Suite

ProSupport Infrastructure Suite is a set of support services that enable customers to build the solution that is right for their organization. It is an industry-leading, enterprise-class support that aligns with the criticality of your systems, the complexity of your environment, and the allocation of your IT resources.

Figure 17. ProSupport Enterprise Suite

	Basic Hardware Support ¹	ProSupport	BEST ProSupport Plus
Outcome Assistance and Advocacy via assigned Technical Customer Success Manager ⓘ			
Enjoy a frictionless customer experience with cross-functional lifecycle management aligned to your goals			✓
Accelerate time-to-value through onboarding assistance, education and success planning			✓
Turn challenges into opportunities with actionable strategies powered by data and AI-driven analytics			✓
Ensure coverage continuity while preparing to scale for future success			✓
Proactive Monitoring & Actionable Insights via Dell's connectivity solutions and tools			
Quickly visualize performance through a current system health score		✓	✓
Cybersecurity monitoring and mitigation recommendations provide another layer of protection		✓	✓
Predictive performance and capacity analysis address bottlenecks		✓	✓
Prevent or plan for downtime with predictive hardware anomaly detection		✓	✓
Energy consumption and carbon footprint forecasting support sustainability and stewardship initiatives		✓	✓
Get ahead of problems with proactive issue detection with automated case creation	✓	✓	✓
Streamline internal IT efforts with efficient service request and escalation management tools	✓	✓	✓
Minimize disruptions by self-dispatching eligible parts	✓	✓	✓
Support Essentials			
Receive an assigned incident manager for Sev 1 issues who will work your issue through to resolution		✓	✓
Count on Mission Critical Support during Sev 1 incidents and natural disasters ⓘ			✓
Keep systems code current and performing at peak through Proactive System Maintenance			✓
Get priority access to senior technical support engineers—skip the queues and callbacks			✓
Bringing your own software? We provide limited 3rd party software support ⓘ			✓
Choose onsite parts delivery and labor response that meets your needs	Next Business Day	NBD or 4-hour	4-hour
Select product coverage that best augments your internal resources	Hardware	Hardware & Software	Hardware & Software
Have an issue? We are here for you by phone, chat and online	Local business hours	24/7/365	24/7/365

ProSupport Plus for Infrastructure

ProSupport Plus for Infrastructure is the ultimate solution for customers seeking preventative maintenance and optimal performance on their business-critical assets. The service caters to customers who require proactive, predictive, and personalized support for systems that manage critical business applications and workloads. When customers purchase PowerEdge server, we recommend ProSupport Plus, our proactive and preventative support service for business-critical systems. ProSupport Plus provides all the benefits of ProSupport, including the following “Top five reasons to buy ProSupport Plus (PSP)”

- 1. Priority access to specialized support experts:** Immediate advanced troubleshooting from an engineer that understands Dell infrastructure solutions.
- 2. Mission Critical Support:** When critical (Severity 1) support issues happen, the customer is assured that we do all that we can to get them back up and running as quickly as possible.
- 3. Technical Customer Success Manager:** A customer’s #1 support advocate, ensuring they get the best possible proactive and predictive support experience.
- 4. Systems maintenance:** On a semiannual basis, we will keep a customer’s ProSupport Plus system(s) up to date by installing the latest firmware, BIOS, and driver updates to improve performance and availability.
- 5. Third-party software support:** Dell is a customer’s single point of accountability for any eligible third-party software that is installed on their ProSupport Plus system, whether they purchased the software from us or not.

ProSupport for Infrastructure

Comprehensive 24x7 support for hardware and software – best for production, but not critical, workloads and applications. The ProSupport service offers highly trained experts around the clock and around the globe to address IT needs. We help minimize disruptions and maximize availability of PowerEdge server workloads with:

- 24x7 support through phone, chat and online
- A central point of accountability for all hardware and software issues
- Hypervisor, operating system, and application support
- Dell security advisories

- Onsite response service levels 4 hour or Next Business Day options
- Proactive issue detection with automated case creation
- Predictive hardware anomaly detection
- Incident Manager assigned for Severity 1 cases
- Collaborative third-party support
- Access to AIOps Platforms - (MyService360, TechDirect, and CloudIQ)
- Consistent experience regardless of where customers are located or what language that they speak.

Basic Hardware Support

Provides reactive hardware support during normal business hours, excluding local national holidays. No software support or software-related guidance. For improved levels of support, choose ProSupport or ProSupport Plus.

Specialty Support Services

Optional specialty support services complement the ProSupport Infrastructure Suite to provide additional proficiencies that are critical for modern data center operations.

Hardware coverage add-ons to ProSupport or ProSupport Plus

- **Keep Your Hard Drive (KYHD), Keep Your Component (KYC), or Keep Your GPU (KYGPU):**

Normally if a device fails under warranty, Dell replaces it using a one-for-one exchange process. KYHD/KYCC/KYGPU gives you the option to retain your device. It provides full control of sensitive data and minimizes security risk by letting you retain possession of failed drives, components, or GPU when receiving replacement parts without incurring additional cost.

- **Onsite Diagnosis Service:**

Ideal for sites with non-technical staff. Dell field technician performs initial troubleshooting diagnosis onsite and transfers to Dell remote engineers to resolve the issue.

- **ProSupport Add-on for HPC:**

Sold as an add-on to a ProSupport service contract, the ProSupport Add-on for HPC provides solution-aware support to cover the additional requirements that are required to maintain an HPC environment such as:

- Access to senior HPC experts
- Advanced HPC cluster assistance: Performance, interoperability, and configuration
- Enhanced HPC solution level end-to-end support
- Remote pre-support engagement with HPC Specialists during ProDeploy implementation

- **ProSupport Add-on for Telco (Respond & Restore):**

An add-on service designed for the top 31 TELCO customers globally, Respond & Restore provides direct access to Dell solution experts who specialize in TELCO carrier-grade support. This add-on also provides a hardware uptime guarantee, meaning if a system fails, Dell has it installed and operational within 4 hours for Severity 1 issues. Dell incurs penalties and fees if SLAs are not met.

Personalized Support and Supplemental Site-wide Expertise

- **Technical Account Manager:**

Designated technology lead who monitors and manages the performance and configuration of specific technology sets.

- **Designated Remote Support:**

Personalized support expert who manages all troubleshooting and resolution of IT assets.

- **Multivendor Support Service:**

Support your third-party devices as one service plan for servers, storage, and networking (includes coverage for: Broadcom, Cisco, Fujitsu, HPE, Hitachi, Huawei, IBM, Lenovo, NetApp, Oracle, Quanta, SuperMicro and others).

Services for large enterprises

- **ProSupport One for Data Center:**

ProSupport One for Data Center offers flexible site-wide support for large and distributed data centers with more than 1,000 assets (combined total of server, storage, networking, so forth). This offering is built on standard ProSupport features that leverage our global scale and are tailored to specific customer needs. While not for everyone, this service option offers a truly unique solution for our largest customers with the most complex environments.

- Team of assigned Services Account Managers with remote or onsite options
- Assigned technical and field engineers who are trained on the customer's environment and configurations.
- On-demand reporting and recommendations that are enabled by ProSupport AIOps tools (MyService360, TechDirect, and CloudIQ)
- Flexible onsite support and parts options that fit their operational model
- A tailored support plan and training for their operations staff

- **ProSupport One for Data Center – CSP (Cloud Serviced Provider) and AI Solution**

ProSupport One for Data Center – CSP and AI Solution is a unique offer that is designed for a limited set of Dell accounts purchasing AI computing solutions greater than 1,000 servers and \$250M in sales. PS1DC - CSP and AI improves the entire services experience combining support, deployment (rack integration), residency services, a designated support engineer, an onsite service engineer, and an onsite parts service as one holistic offer. Special pricing has been determined to compete effectively against competitors and provide the best customer experience. PS1DC for CSP and AI can only be sold with XE Servers and all networking platforms (Dell and NVIDIA). All other products would be eligible for the standard PS1DC, not this unique offer. More details on PS1DC for CSP and AI [here](#).

- **Onsite Parts Service (OPS)**

Ideal for large organizations that have their own staff to support their data center. Dell offers a service that is called Onsite Parts Service (OPS) from Dell Services. OPS manages parts inventory located at the customer's designated facility. The Logistics Online Inventory Solution (LOIS) program will use software to support the monitoring and automatic replenishment of inventory stored on the customer site. . Each replacement part would automatically initiate a replenishment of the parts inventory that is shipped the next day or delivered onsite by Dell during a regular scheduled visit (called Scheduled Onsite Service). As part of the LOIS system, customers can integrate their systems directly to Dell TechDirect using APIs to help streamline the support management process.

End-of-Life Services

- **Post Standard Support (PSS)**

Extend service life beyond the initial seven years of ProSupport, adding up to five more additional years of hardware coverage.

- **Data Sanitization & Data Destruction**

Renders data unrecoverable on repurposed or retired products, ensuring security of sensitive data and enabling compliance and provides NIST-compliant certification.

- **Asset Recovery Services**

Recycle, resale, and disposal of hardware. Helps you securely and responsibly retire IT assets that are no longer needed while protecting both your business and the planet.

ProDeploy Infrastructure Suite

ProDeploy Infrastructure Suite provides various deployment offerings that satisfy a customer's unique needs. It is made up of various sub-offers: Factory Configuration Services, Rack Integration, Basic Deployment, ProDeploy, ProDeploy Plus, and optionally ProDeploy FLEX which allows for some customization of the features listed.

ProDeploy Infrastructure Suite

Versatile choices for accelerated deployments

NOTE: All XE Series servers require mandatory deployment

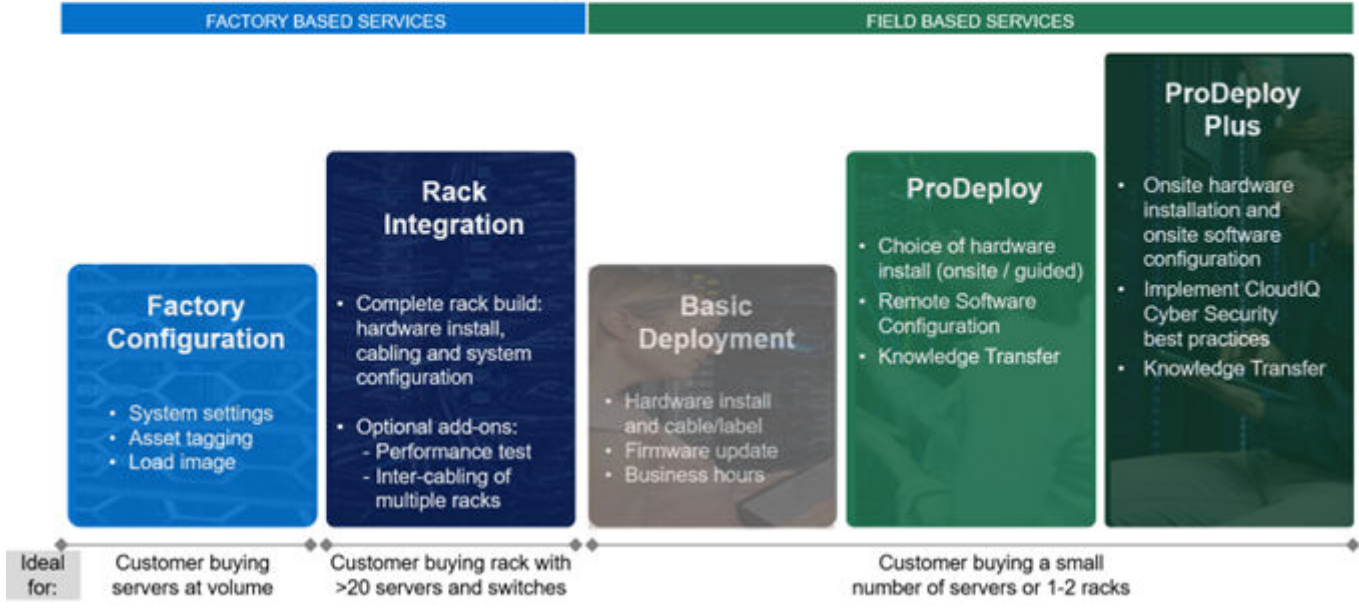

Figure 18. ProDeploy Infrastructure Suite

Factory-based Services

Pre-configured systems or complete racks, customized prior to shipping to the customer's site.

Customer Rack Integration or ProDeploy FLEX Rack Integration

Dell offers robust custom rack integration services through two main programs: Enterprise Rack Integration Services and Integrated Rack Scalable Systems (IRSS). These services are designed to streamline deployment, reduce complexity, and optimize performance for data centers, edge environments, and AI workloads. These factory services are purchased as a custom engagement or as ProDeploy Flex Rack Integration SKUs.

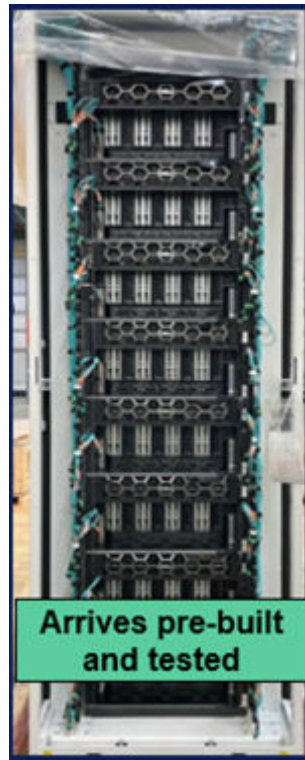

Figure 19. Pre-configured system



Figure 20. Pre-configured system

Factory Configuration

Ideal for customers buying servers in volume and seeking pre-configuration prior to shipping such as: custom image, system settings, and asset tagging so it arrives ready to use out of the box. Furthermore, servers are packaged and bundled to meet specific shipping and distribution requirements for each customer location to facilitate the rollout process. Once the server is onsite, Dell can install and configure the server to the environment using any of the field-based deployment services outlined in the next section.

Field-based services

Put PowerEdge servers to work faster with Dell field-based deployment services. Whether we are deploying one server to one thousand – we have you covered. Dell provides versatile delivery options to fit every budget and operating model.

- **ProDeploy Plus:** Elevate Infrastructure deployments with our most complete service from planning through onsite hardware installation and software configuration including the implementation of cybersecurity best practices. ProDeploy Plus provides the skill and scale that is needed to successfully execute demanding deployments in today's complex IT environments. The deployment starts with a site readiness review and implementation plan. Certified deployment experts perform the software configuration to include setup of leading operating systems and hypervisors. Dell will also configure PowerEdge software tools to include iDRAC and OpenManage system utilities as well as support AI/Ops platforms: MyService360, TechDirect, and

CloudIQ. Unique to ProDeploy Plus, the cybersecurity implementation helps customers understand potential security risks and make recommendations for reducing product attack surfaces. The system is tested, validated prior to completion. The customer will also receive full project documentation and knowledge transfer to complete the process.

- **ProDeploy:** ProDeploy provides remote software configuration and choice of hardware installation (onsite or guided). ProDeploy is great for customers who are price sensitive or willing to participate in some portion of the deployment to include providing remote access to their network. The ProDeploy remote software includes everything mentioned in ProDeploy Plus except it does not include the added value, cybersecurity implementation, and implementation best practices.
- **Basic Deployment:** Basic Deployment delivers worry-free professional installation by experienced technicians. This service is often sold to Competency Enabled Partners who will have Dell do the hardware installation while they complete the software configuration. Furthermore, Basic Deployment tends to be purchased by large enterprises who have smart technical staff. These companies just need Dell to install the hardware, and they will perform the software configuration. The last use case for Basic Deployment is when paired with Factory Configuration services. The servers are preconfigured in the factory, and the basic deployment service will install the system into the rack to finalize the deployment.

ProDeploy Infrastructure Suite | Field services

		Basic Deployment	ProDeploy	ProDeploy Plus
Pre-deployment	Single point of contact for project management	-	●	In region
	Site readiness review and implementation planning	-	●	●
Deployment	Deployment service hours	Business hours	24/7	24/7
	Hardware installation options	Onsite	Onsite or guided ¹	Onsite
	System software installation and configuration options	-	Remote	Onsite
	Install connectivity software based on Secure Connect Gateway technology ²	-	●	●
	Implement CyberSecurity best practices and policies in APEX AIOps Infrastructure Observability	-	-	●
Post-deployment	Deployment verification, documentation and knowledge transfer	-	●	●
	Configuration data transfer to Dell technical support	-	●	●
Online collaboration	Online collaborative platform in TechDirect for planning, managing and tracking delivery	-	●	●

¹ Choose from onsite hardware installation or a guided option including project specific instructions, documentation and live expert guidance
² Post deployment use for intelligent, automated support & insights

Figure 21. ProDeploy Infrastructure Suite - Field services

Supplemental Deployment Services

Additional ways to expand scope or deploy for unique scenarios.

Two Host Adder (requires PD/PDP)

Deploying new storage, compute, or networking devices may require interconnection to other servers (also called hosts). The Dell delivery team will set up four hosts per device as part of every ProDeploy service. For example, if the customer is buying two storage arrays the ProDeploy service will automatically include connectivity of four hosts each (4x2=8 total hosts per project since there are two devices). This supplemental “Two Host Adder” service provides for the configuration of additional hosts above what is already provided as part of the ProDeploy service. In many cases, customers can work with us while we set up the included hosts, so they may understand how to do the rest themselves. Always ask the customer how many hosts are being connected and sell the host adder depending on the customer’s technology skillset. Note that this service applies to the connectivity of Dell devices not 3rd party devices.

Additional Deployment Services (ADT) – sold with or without PD/PDP

You can expand the scope of a ProDeploy engagement leveraging Additional Deployment Time (ADT). ADT covers additional tasks above the normal deliverables of the ProDeploy offers. ADT can also be used as a standalone service without ProDeploy.

SKUs are available for both Project Management and Technical Resource Expertise. SKUs are sold as blocks of four hours remote or eight hours onsite. The delivery team can help in scoping the number of hours required for additional tasks.

Data Migration Services

Migrating data sets is no easy task. Our experts use proven tools and process to streamline data migrations and avoid compromising data. A customer project manager works with our experienced team of experts to create a migration plan. Data migration is part of every technology upgrade, platform change, and shift to the cloud. You can rely on Dell data migration services to perform a seamless transition.

Residency Services

Certified technical professionals act like an extension of your IT staff to enhance internal capabilities and resources and help you realize faster adoption and maximized ROI of new technology. Residency Services help customers transition to new capabilities quickly by leveraging specific technology skill sets. Residency experts can provide post implementation management and knowledge transfer that is related to a new technology acquisition or day-to-day operational management of the IT infrastructure.

- Global experts available to serve in-person (onsite) or virtual (remote)
- Engagements starting at 2 weeks with flexibility to adjust
- Residency is available for project management needs, and many different technology skills sets such as: Server, storage, Gen AI, networking, security, multi-cloud, data mgmt., and modern workforce application residents

Unique Deployment Scenarios

Custom Deployment Services

When a deployment is beyond the scope of the ProDeploy Infrastructure Suite, you can turn to the custom deployment services team to address complex implementation scenarios and customer unique requirements. The Dell custom deployment team is staffed with solution architects who will assist with customer scoping calls to define the project and develop the statement of work. Custom services can handle a wide range of deployments that can be performed in the factory or onsite. All custom engagement services are requested through SFDC.

Deployment of AI or HPC using Cluster Build Services

Once the integrated rack arrives the data center or is built onsite, Dell can also convert the racks into a large computing cluster. Dell provides several deploy options for Artificial Intelligence (AI) or High-Performance Computing (HPC) implementations. These complex environments require specialists that understand advanced feature sets to create a unified computing cluster for the most demanding workloads. Choose one of the cluster build add-ons below.

Increase Time to Value and with ProDeploy Flex and Cluster Builds

Sell as Custom Quote or Standard SKUs
Add-ons 1 & 2 arriving as standard SKUs in Sept.

ProDeploy Flex Rack Integration or ProDeploy Flex Onsite + **Cluster Build Add-ons**
Select one or more add-ons below



		Ideal for
1	Physical Configuration of Cluster <ul style="list-style-type: none"> Onsite Infrastructure Assessment Installation of switches¹ Inter-rack cabling and labeling Liquid connectivity and leak test² 	Customers needing help with installing the network, inter-rack cabling, and fabric testing
2	Logical Configuration of Cluster <ul style="list-style-type: none"> Review system design and plan Configure switches & mgmt nodes Validation and acceptance testing 	Customers requiring cluster configuration and essential testing of the solution
3	AI Network Design Services <ul style="list-style-type: none"> 2-week intensive consultation that accelerates AI network performance and maximizes operational efficiency³ 	Customers seeking foundational design strategy to achieve optimal performance

When the environment is demanding, your configuration can't be average ★★★★★

Key Benefits:

- Factory rack integration enables faster time to value and reliability
- Reduce onsite setup time and fast track to production
- Fine-tuned system performance based on workload types
- Services aligned with enterprise-grade security standards
- Final testing and customer handoff lessen amount of support calls

1 -- Network switches to be installed in factory or onsite depending on requirements. Choose options: ProDeploy Flex Rack Integration or ProDeploy Flex Onsite combined with PD Flex Cluster Add-ons
 2 -- If applicable. Leak test performed in factory and again onsite which is limited to in-rack CXK! Secondary Fluid Network (SFN) design and deployment quoted separately by Vertiv or Mollnar.
 3 -- AI Network Design Service is ordered as a Custom Service Engagement via SFDC or SFP

Figure 22. Deployment choices for cluster implementation

DAY 2 – Automation Services with Ansible

Dell solutions are built as “automation ready” with integrated APIs (Application Programming Interfaces) to allow customers to programmatically call actions on the product through code. Although Dell has published Ansible automation use cases, some customers need additional assistance with GitOps. By the end of the service, the customer will have the foundational components required to accelerate automation and understand how the programming works together: Day 1 and Day 2 use case automation scripts (ansible modules), CI/CD tool (Jenkins), and Version control (Git).

Dell Technologies Consulting Services

Our expert consultants help customers transform faster, and quickly achieve business outcomes for the high-value workloads Dell PowerEdge systems can handle. From strategy to full-scale implementation, Dell Technologies Consulting can help determine how to perform IT, workforce, or application transformation. We use prescriptive approaches and proven methodologies that are combined with the portfolio and partner ecosystem of Dell Technologies to help achieve real business outcomes. From multicloud, applications, DevOps, and infrastructure transformations, to business resiliency, data center modernization, analytics, workforce collaboration, and user experiences—we are here to help.

Dell Managed Services

Some customers prefer Dell to manage the complexity and risk of daily IT operations, Dell Managed Services utilizes proactive, AI enabled delivery operations and modern automation to help customers realize desired business outcomes from their infrastructure investments. With these technologies, our experts run, update, and fine-tune customer environments that are aligned with service levels, while providing environment-wide and down-to-the-device visibility. There are two types of managed service offers. First the outsourcing model or CAPEX model where Dell manages the customer owned assets using our people and tools. The second is the as-a-Service model or OPEX model called APEX. In this service, Dell owns all technology and all the management of it. Many customers will have a blend of the two management types depending on the goals of the organization.

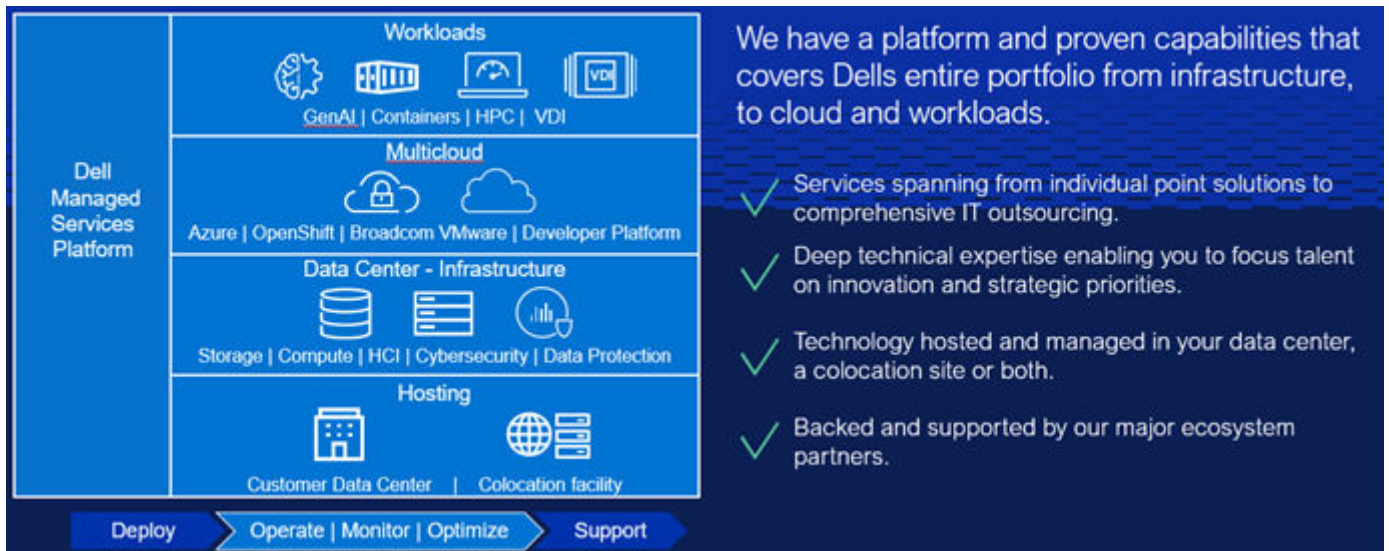

Figure 23. Dell Managed Services

Cyber-Security Services

Managed Detection and Response (MDR)

Dell Managed Detection and Response Pro Plus is our fully-managed, 360° security operations solution comprised of our most cutting-edge, preventive and responsive cybersecurity services. MDR Pro Plus was designed with your top security concerns in mind, allowing you to focus on your core business goals while Dell handles your security operations. First, we have Vulnerability Management. With this service, we'll do ongoing scanning of the customer's environment looking for software that needs to be patched. Next is Pen Testing and Attack Simulation Management. This service will continuously validate security controls and policies with automated Breach and Attack Simulation (BAS), because a misconfiguration can lead to an exposure which an attacker can exploit. The service also includes an annual penetration test to determine if a skilled threat actor could exploit pathways leading to critical assets or data. Third, Managed Security Awareness Training. This service will educate the customer's end users so that they don't inadvertently put the customer at risk. If you think about our annual compliance training modules, there is always a security module. This is the same type of thing, but rather than once a year, it will be smaller, bite-size pieces of content delivered throughout the year. Fourth is our Managed Detection and Response service which provides 24x7 threat detection and investigation, analysis of end-to-end activity by threat actors, threat hunting, and quick initiation of cyber incident response when needed. Customers can choose between Secureworks Taegis XDR, CrowdStrike Falcon XDR or Microsoft Defender XDR as the security analytics platform our analysts will use to monitor their environment. All four of these services are delivered by experienced, certified Dell security experts using advanced technology such as the Secureworks Taegis XDR, CrowdStrike Falcon XDR or Microsoft Defender XDR security platforms.

Dell Technologies Education Services

Build the IT skills required to influence the transformational outcomes of the business. Enable talent and empower teams with the right skills to lead and perform transformational strategy that drives competitive advantage. Leverage the training and certification that is required for real transformation.

Dell Technologies Education Services offers PowerEdge server training and certifications that are designed to help customers achieve more from their hardware investment. The curriculum delivers the information and the practical, firsthand skills that their team must confidently install, configure, manage, and troubleshoot Dell servers.

To learn more or register for a class today, see Education.Dell.com.

Resources

[Service for powerEdge](#)

Appendix A: Additional specifications

Topics:

- Chassis dimensions
- Chassis weight
- NIC port specifications
- Video specifications
- USB Ports
- PSU rating
- Environmental specifications

Chassis dimensions

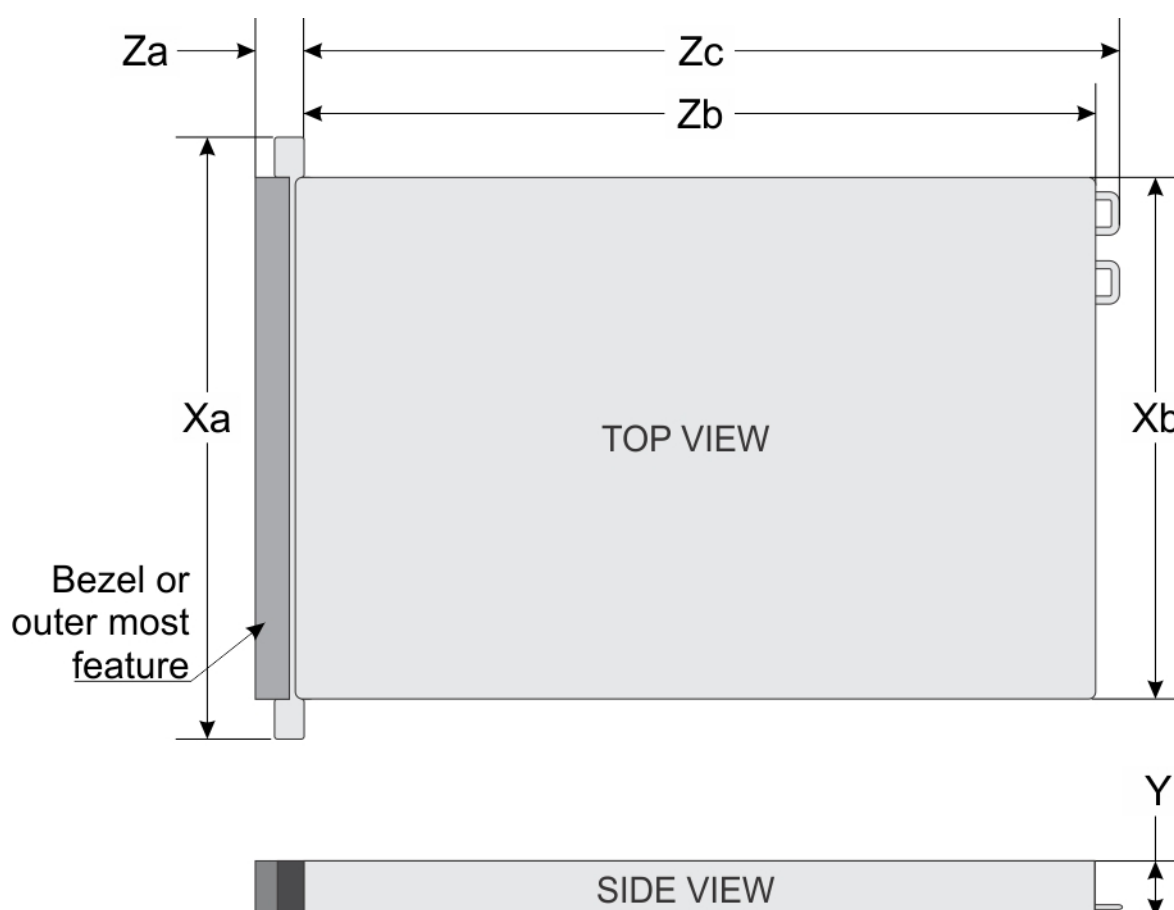

Figure 24. Chassis dimensions

Table 27. PowerEdge R360 chassis dimensions

Drives	Xa	Xb	Y	Za	Zb	Zc
12 drives	482.0 mm (18.976 inches)	434.0 mm (17.086 inches) CC:	42.8 mm (1.685 inches)	35 mm (1.378 inches)	483.82 mm (19.048 inches)	512.53 mm (20.178 inches)

Table 27. PowerEdge R360 chassis dimensions

Drives	Xa	Xb	Y	Za	Zb	Zc
		434.0 mm (17.08 inches)			Ear to PSU Surface	inches) Ear to PSU handle

NOTE: Zb is the nominal rear wall external surface where the system board I/O connectors reside.

NOTE: Xb is unique to this system and has two values for the Storage module (SM) and the Compute Module (CC) .

Chassis weight

Table 28. PowerEdge R360 system weight

System configuration	Maximum weight (with all drives/SSDs)	
A server with fully populated drives	2.5-inch drives	11.64 kg (25.68 lb)
	3.5-inch drives	13.23 kg (29.17 lb)
A server without drives and PSU installed	2.5-inch drives	8.36 kg (18.45 lb)
	3.5-inch drives	9.01 kg (19.88 lb)

NIC port specifications

The system supports up to two 10/100/1000 Mbps Network Interface Controller (NIC) ports embedded on the LAN on Motherboard (LOM) and up to four ports integrated on the optional network cards.

Table 29. NIC port specification for the system

Feature	Specifications
LOM	1 Gb x 2
Network Card (optional)	1 Gb x 4, 10 Gb x 2, 10 Gb x 4

Video specifications

The platform supports the following video resolution and refresh rates:

Table 30. Video specifications for R360

Resolution	Refresh Rate	Sestotal Freq.	Pixel Clock	DVO DisplayPort
1024 x 768	60 Hz	48.4 kHz	65.0 MHz	Yes*
1280 x 800	60 Hz	49.7 kHz	83.5 MHz	Yes*
1280 x 1024	60 Hz	64.0 kHz	108.0 MHz	Yes*
1360 x 768	60 Hz	47.71 kHz	85.5 MHz	Yes*
1440 x 900	60 Hz	55.9 kHz	106.5 MHz	Yes*
1600 x 900	60 Hz	55.54 kHz	97.75 MHz	Yes*
1600 x 1200	60 Hz	75.0 kHz	162.0 MHz	Yes*
1680 x 1050	60 Hz	64.7 kHz	119.0 MHz	Yes*
1920 x 1080	60 Hz (RB)	67.158 kHz	173.0 MHz	No

Table 30. Video specifications for R360 (continued)

Resolution	Refresh Rate	Sestotal Freq.	Pixel Clock	DVO DisplayPort
1920 x 1200	60 Hz (RB)	74.556 kHz	193.25 MHz	No

*DVO - DP is for investigation only, dependent on Nuvoton DVO capabilities to support up to 165 MHz.

*(RB) - Reduced Blanking for Digital Displays requiring less blank time. It was introduced for Signal Integrity improvements by reducing Pixel Clock rates for VGA- Analog input devices.

USB Ports



Figure 25. Front USB port

1. USB 2.0 Port



Figure 26. Rear USB ports

1. USB 2.0 Port
2. USB 3.2 Gen1

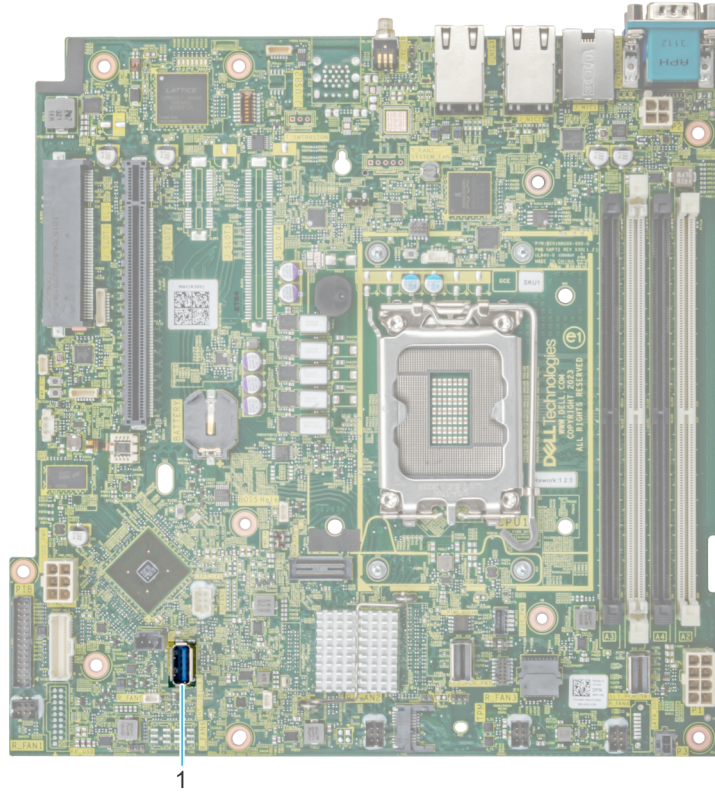

Figure 27. Internal USB Port

1. USB 3.2 Gen1

Table 31. Systems USB Specifications

Front		Rear		Internal	
USB port type	No. of ports	USB port type	No. of ports	USB port type	No. of ports
USB 2.0-compliant port	One	USB 2.0-compliant port	One	Internal USB 3.2 Gen1-compliant port	One
iDRAC Direct port (Micro-AB USB 2.0-compliant port)	One	USB 3.2 Gen1-compliant ports	One		

PSU rating

Below table lists the power capacity the PSUs in high/low line operation mode.

Table 32. PSUs highline and lowline ratings

—	600 W Platinum	700 W Titanium
Peak Power (Highline/-72 VDC)	600 W	700 W
Lowline/-40 VDC	600 W	NA
Highline 240 VDC	600 W	700 W
Highline 200 ~ 380VDC	NA	NA
DC -(48 to 60V)	NA	NA

The PowerEdge R360 supports up to two AC power supplies with 1+1 redundancy, autosensing, and auto switching capability.

If two PSUs are present during POST, a comparison is made between the wattage capacities of the PSUs. In case the PSU wattages do not match, the larger of the two PSUs is enabled. Also, there is a PSU mismatch warning that is displayed in BIOS, iDRAC, or on the system LCD.

If a second PSU is added at run-time, in order for that particular PSU to be enabled, the wattage capacity of the first PSU must equal the second PSU. Otherwise, the PSU is flagged as unmatched in iDRAC and the second PSU is not enabled.

Dell PSUs have achieved Titanium or Platinum efficiency levels as shown in the table below.

Table 33. PSU efficiency level

Efficiency Targets by Load						
Form factor	Output	Class	10%	20%	50%	100%
Redundant 60 mm	600W	Platinum	-	90%	94%	91%
	700W	Titanium	90%	94%	96%	91%

Environmental specifications

NOTE: For additional information about environmental certifications, refer to the *Product Environmental Datasheet* located with the *Documentation* on [Dell Support](#).

Table 34. Continuous Operation Specifications for ASHRAE A2

-	Allowable continuous operations
Temperature range for altitudes <= 900 m (<= 2953 ft)	10–35°C (50–95°F) with no direct sunlight on the equipment
Humidity percent range (non-condensing at all times)	8% RH with -12°C minimum dew point to 80% RH with 21°C (69.8°F) maximum dew point
Operational altitude de-rating	Maximum temperature is reduced by 1°C/300 m (33.8°F/984 Ft) above 900 m (2953 Ft)

Table 35. Continuous Operation Specifications for ASHRAE A3

-	Allowable continuous operations
Temperature range for altitudes <= 900 m (<= 2953 ft)	5–40°C (41–104°F) with no direct sunlight on the equipment
Humidity percent range (non-condensing at all times)	8% RH with -12°C minimum dew point to 85% RH with 24°C (75.2°F) maximum dew point
Operational altitude de-rating	Maximum temperature is reduced by 1°C/175 m (33.8°F/574 Ft) above 900 m (2953 Ft)

Table 36. Continuous Operation Specifications for ASHRAE A4

-	Allowable continuous operations
Temperature range for altitudes <= 900 m (<= 2953 ft)	5–45°C (41–113°F) with no direct sunlight on the equipment
Humidity percent range (non-condensing at all times)	8% RH with -12°C minimum dew point to 90% RH with 24°C (75.2°F) maximum dew point
Operational altitude de-rating	Maximum temperature is reduced by 1°C/125 m (33.8°F/410 Ft) above 900 m (2953 Ft)

Table 37. Common Environmental Specifications for ASHRAE A2, A3, and A4

-	Allowable continuous operations
Maximum temperature gradient (applies to both operation and non-operation)	20°C in an hour* (36°F in an hour) and 5°C in 15 minutes (41°F in 15 minutes), 5°C in an hour* (41°F in an hour) for tape

Table 37. Common Environmental Specifications for ASHRAE A2, A3, and A4 (continued)

-	Allowable continuous operations
	i NOTE: * - Per ASHRAE thermal guidelines for tape hardware, these are not instantaneous rates of temperature change.
Non-operational temperature limits	-40 to 65°C (-104 to 149°F)
Non-operational humidity limits	5% to 95% RH with 27°C (80.6°F) maximum dew point
Maximum non-operational altitude	12,000 meters (39,370 feet)
Maximum operational altitude	3,048 meters (10,000 feet)

Table 38. Maximum vibration specifications

Maximum vibration	Specifications
Operating	0.21 G _{rms} at 5 Hz to 500 Hz (all operation orientations)
Storage	1.88 G _{rms} at 10 Hz to 500 Hz for 15 minutes (all six sides tested)

Table 39. Maximum shock pulse specifications

Maximum shock pulse	Specifications
Operating	Six consecutively executed shock pulses in the positive and negative x, y, and z axis of 6 G for up to 11 ms.
Storage	Six consecutively executed shock pulses in the positive and negative x, y, and z axis (one pulse on each side of the system) of 71 G for up to 2 ms.

Particulate and gaseous contamination specifications

The following table defines the limitations that help avoid any equipment damage or failure from particulates and gaseous contamination. If the levels of particulates or gaseous pollution exceed the specified limitations and result in equipment damage or failure, you must rectify the environmental conditions. Remediation of environmental conditions is the responsibility of the customer.

Table 40. Particulate contamination specifications

Particulate contamination	Specifications
Air filtration: Conventional Data Center only	Data center air filtration as defined by ISO Class 8 per ISO 14644-1 with a 95% upper confidence limit i NOTE: Filtering room air with a MERV8 filter, as specified in ANSI/ASHRAE Standard 127, is a recommended method for achieving the necessary environmental conditions. i NOTE: Air entering the data center must have MERV11 or MERV13 filtration. i NOTE: This condition applies to data center environments only. Air filtration requirements do not apply to IT equipment designed to be used outside a data center, in environments such as an office or factory floor.
Walk-Up Edge Data Center or Cabinet (sealed, closed loop environment)	Filtration is not required for cabinets that are anticipated to be opened six times or less per year. Class 8 per ISO 1466-1 filtration as defined above is required otherwise. i NOTE: In environments commonly above ISA-71 Class G1 or that may have known challenges, special filters may be required.
Conductive dust: data center and non-data center environments	Air must be free of conductive dust, zinc whiskers, or other conductive particles.

Table 40. Particulate contamination specifications (continued)

Particulate contamination	Specifications
	<p>i NOTE: Conductive dust, which can interfere with equipment operation, can originate from various sources, including manufacturing processes and zinc whiskers that may develop on the plating of raised floor tiles.</p> <p>i NOTE: This condition applies to data center and non-data center environments.</p>
Corrosive dust: data center and non-data center environments	<ul style="list-style-type: none"> Air must be free of corrosive dust. Residual dust present in the air must have a deliquescent point less than 60% relative humidity. <p>i NOTE: This condition applies to data center and non-data center environments.</p>

Table 41. Gaseous contamination specifications

Gaseous contamination	Specifications	Notes
Copper coupon corrosion rate	ISA-71 Class G1: <300 Å/month	Per ANSI/ISA71.04
Silver coupon corrosion rate	ISA-71 Class G1: <200 Å/month	Per ANSI/ISA71.04

Thermal restriction matrix

Table 42. Processor and heat sink matrix

Heat sink	Configuration No
1U HSK	All configurations

Table 43. Label reference

Label	Description
STD	Standard
LP	Low profile
FH	Full height

Table 44. Thermal restriction matrix (Without GPU)

Configuration		Configuration 1 2.5 inch and 3.5 inch Drives With Riser	Configuration 2 2.5 inch and 3.5 inch Drives With N1- BOSS	Configuration 3 2.5 inch and 3.5 inch Drives Without Riser and N1 - BOSS	Ambient temperature
CPU TDP/ cTDP	≤ 80 W	4 x STD Fans 1U STD HSK	1 x Silver Fan, 3 x STD Fans 1U STD HSK	3 x STD Fan 1U STD HSK	35°C (95°F)
	95 W	4 x STD Fans 1U Performance HSK	1 x Silver Fan, 3 x STD 1U Performance HSK	3 x STD Fan 1U Performance HSK	35°C (95°F)

i **NOTE:** Refer to the ASHRAE A3/A4 environment specifications under Appendix A for detailed configuration limitation.

Table 45. Thermal restriction matrix (With GPU)

Configuration		Configuration 1 2.5 inch and 3.5 inch Drives With Riser	Configuration 2 2.5 inch and 3.5 inch Drives With N1- BOSS	Configuration 3 2.5 inch and 3.5 inch Drives Without Riser and N1 - BOSS	Ambient temperature
CPU TDP/ cTDP	≤ 80 W	4 x STD Fans 1U STD HSK	1 x Silver Fan, 3 x STD Fans 1U STD HSK	N/A	35°C (95°F)
	95 W	4 x STD Fans 1U Performance HSK	1 x Silver Fan, 3x STD 1U Performance HSK	N/A	35°C (95°F)

NOTE: When A2 GPU card is populated, PCIe slot 2 has to be populated or should have a blank installed.

Table 46. Fan Location

Chassis	Configuration	Fan Quantity	Fan Location
2.5 inch and 3.5 inch Drives	With Riser Card	4	Fan 1 (STD), Fan 2, Fan 3, Fan 4
2.5 inch and 3.5 inch Drives	With N1-BOSS Module	4	Fan 1 (Silver), Fan 2, Fan 3, Fan 4
2.5 inch and 3.5 inch Drives	Without Riser and N1- BOSS Module	3	Fan 2, Fan 3, Fan 4

Thermal air restrictions

ASHRAE A3/A4 environment

- The operating temperature is for a maximum altitude of 950 m for ASHRAE A3/A4 Cooling.
- If over 950 m, we need to do the ambient temperature de-rating.
- CPU TDP greater than 80 W is not supported.
- BOSS-N1 (M.2) module is not supported.
- A2 GPU card is not supported.
- Non-Dell qualified peripheral cards and/or peripheral cards greater than 25 W are not supported.
- Two PSUs are required in redundant mode.

Appendix A. Standards compliance

The system conforms to the following industry standards.

Table 47. Industry standard documents

Standard	URL for information and specifications
ACPI Advance Configuration and Power Interface Specification, v6.4	ACPI
Ethernet IEEE Std 802.3-2022	IEEE Standards
MSFT WHQL Microsoft Windows Hardware Quality Labs	Windows Hardware Compatibility Program
IPMI Intelligent Platform Management Interface, v2.0	IPMI
DDR5 Memory DDR5 SDRAM Specification	JEDEC Standards
PCI Express PCI Express Base Specification, v5.0	PCIe Specifications
PMBus Power System Management Protocol Specification, v1.2	Power System Management Protocol Specification
SAS Serial Attached SCSI, 3 (SAS-3) (T10/INCITS 519)	SCSI Storage Interfaces
SATA Serial ATA Rev. 3.3	SATA IO
SMBIOS System Management BIOS Reference Specification, v3.3.0	DMTF SMBIOS
TPM Trusted Platform Module Specification, v1.2 and v2.0	TPM Specifications
UEFI Unified Extensible Firmware Interface Specification, v2.7	UEFI Specifications
PI Platform Initialization Specification, v1.7	
USB Universal Serial Bus v2.0 and SuperSpeed v3.0 (USB 3.1 Gen1)	USB Implementers Forum, Inc. USB
NVMe Express Base Specification. Revision 2.0c	NVMe
NVMe Command Set Specifications	
1. NVM Express NVM Command Set Specification. Revision 1.1c	
2. NVM Express Zoned Namespaces Command Set. Revision 1.0c	
3. NVM Express® Key Value Command Set. Revision 1.0c	
NVMe Transport Specifications	
1. NVM Express over PCIe Transport. Revision 1.0c	
2. NVM Express RDMA Transport Revision. 1.0b	
3. NVM Express TCP Transport. Revision 1.0c	
NVMe NVM Express Management Interface. Revision 1.2c	
NVMe NVMe Boot Specification. Revision 1.0	

Appendix C Additional resources

Table 48. Additional resources

Resource	Description of contents	Location
Installation and Service Manual	<p>This manual, available in PDF format, provides the following information:</p> <ul style="list-style-type: none"> • Chassis features • System Setup program • System indicator codes • System BIOS • Remove and replace procedures • Diagnostics • Jumpers and connectors 	Dell.com/Support/Manuals
Getting Started Guide	<p>This guide ships with the system, and is also available in PDF format. This guide provides the following information:</p> <ul style="list-style-type: none"> • Initial setup steps 	Dell.com/Support/Manuals
Rack Installation Guide	<p>This document ships with the rack kits, and provides instructions for installing a server in a rack.</p>	Dell.com/Support/Manuals
System Information Label	<p>The system information label documents the system board layout and system jumper settings. Text is minimized due to space limitations and translation considerations. The label size is standardized across platforms.</p>	Inside the system chassis cover
QR code for system resources	<p>This code on the chassis can be scanned by a phone application to access additional information and resources for the server, including videos, reference materials, service tag information, and Dell contact information.</p>	Inside the system chassis cover
Enterprise Infrastructure Planning Tool (EIPT)	<p>The Dell online EIPT enables easier and more meaningful estimates to help you determine the most efficient configuration possible. Use EIPT to calculate the power consumption of your hardware, power infrastructure, and storage.</p>	Dell.com/calc