

# MOBILE HAND SINK

## Self Contained Portable Hand Sink

"HS" SERIES

### Portable hand sink is self-contained to allow hand washing and sanitizing in remote serving locations

- 1** FWE's portable hand sinks are perfect for hosting an event in any location, making it possible to offer practical hand washing for sanitary food preparation whenever it is needed
- 2** Made for transport applications - FWE hand sinks are fully constructed of stainless steel and equipped with heavy-duty maintenance free casters
- 3** Marine top edge prevents spills and drips while on the move
- 4** Provided with 5 gallon fresh water tank for consistent draw and a 7 gallon gray water tank to hold drainage
- 5** Water heater with adjustable thermostat (65°-145°F) quickly warms water for dispensing when needed
- 6** Lockable door prevents unauthorized access for safety and security
- 7** 8" deck mount nozzle and quarter turn handles make it easy to turn water on and off
- 8** Additional standard features include: built in backsplash, soap dispenser and removable paper towel dispenser, mounted per customer specification

**\*Two year limited warranty**

All Stainless Steel Construction



Water Tanks



Lockable Door



8" Deck Mount Nozzle

# SPECIFICATIONS

## MOBILE HAND SINK

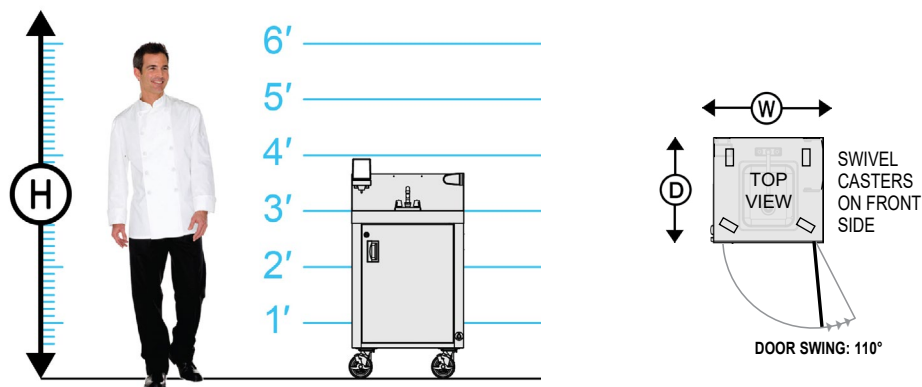

OVERALL EXTERIOR DIMENSIONS IN. (mm) (Height Includes Casters)				CLASS 150		
MODEL NUMBER	HIGH [A] "H"	DEEP "D"	WIDE "W"	NO. OF DOORS	CASTER SIZE	SHIP WT. LBS. (KG)
	47.25" (1201)	23" (584)	24" (610)	1	5"	200 (91)

[A] Height without soap dispenser: 44"

ELECTRICAL DATA	
VOLTS	120
WATTS	1625
AMPS	13.5
HERTZ	60
PHASE	Single
PLUG USA	5-15P
PLUG CANADA	5-20P

**CONSTRUCTION.** Heliarc welded, single unit construction of 18 gauge stainless steel with easy-to-clean coved corners. Front edge shall have raised marine nosing to contain water.  
**DOORS AND LATCHES.** Flush mounted, stainless steel door. Magnetic recessed pull handle with locking cam latch. Heavy duty pin style hinges

**CASTERS.** Maintenance free polyurethane fire casters in a configuration of two (2) rigid and two (2) swivel with brake.  
**WATER CAPACITY.** The unit shall include one (1) five gallon fresh water tank and one (1) seven gallon waste water tank. 120 volt, 1625 watt electric water heater with adjustable thermostat provides a temperature range of 65°-145°F (19°-62°C) and heats up to 2.7 gallons of water. Glass insulated tank for thermal efficiency and fast recovery.

**ELECTRICAL CHARACTERISTICS.** 3 wire grounded 10 foot extension power cord and plug are fed through front side cord exit. Alternative left side cord exit provided. See electrical data chart above for amperage and receptacle configuration.  
**INSTALLATION.** Unit should not be installed in an area where adverse environmental conditions are present.

**DOORS**  
 Left hand door hinging  
**CASTERS**  
 All swivel or larger casters  
**EXTRAS**  
 Full extension bumper  
 Cord winding bracket  
 Corner bumpers  
 Extra fresh water tank  
 Extra waste water tank