

MOBILE HAND SINKS

Contactless Self Contained Portable Hand Sink with Water Heater

"HS" SERIES

Contactless portable hand sink with water heater is self-contained to allow safe hand washing and sanitizing in remote locations

- 1 FWE's contactless portable hand sinks are perfect for any location, making it possible to offer practical hand washing when it is needed to meet safety standards
- 2 Faucet and soap dispenser both have highly responsive, automatic motions sensors for safe and touchless hand washing
- 3 Made for transport applications - FWE hand sinks are fully constructed of stainless steel and equipped with heavy-duty maintenance free casters
- 4 Marine top edge and backsplash prevent spills and drips while on the move
- 5 Provided with a 5 gallon fresh water tank for consistent draw and a 7 gallon waste water tank to hold drainage
- 6 Water heater with adjustable thermostat (65°-145°F) quickly warms water for dispensing when needed
- 7 Lockable door prevents unauthorized access for safety and security
- 8 Paper towel holder and cord exit can be easily moved to either side, providing flexibility in field placement (only one cord exit on HS-24-ES)

***Two year limited warranty**

EXECUTIVE SERIES
(MAPLE WOOD)
NATURAL FINISH



Touchless Faucet & Soap Dispenser



Built for Transport



Water Tanks

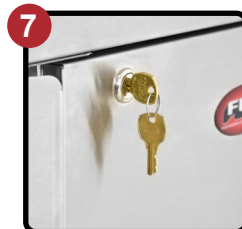

Lockable Door

SPECIFICATIONS

MOBILE HAND SINKS

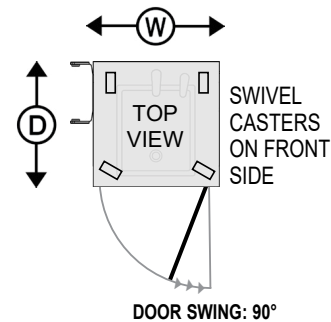
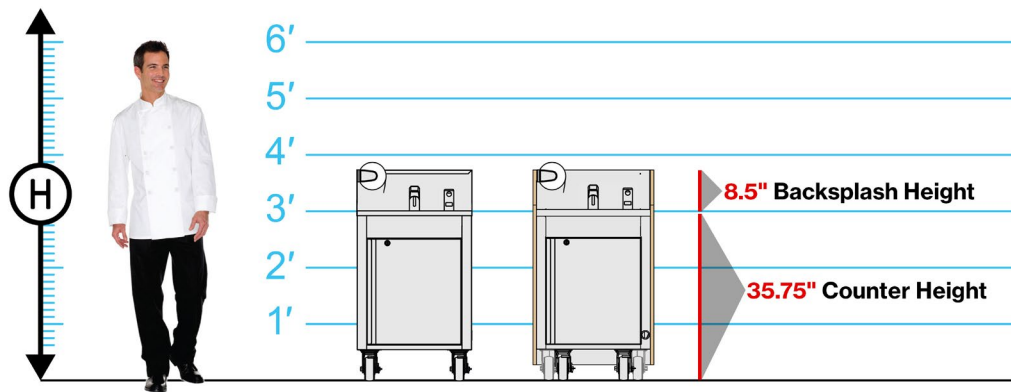

MODEL NUMBER	OVERALL EXTERIOR DIMENSIONS IN. (mm) (Height Includes Casters)			CLASS 175		
	HIGH "H"	DEEP "D"	WIDE* "W"	NO. OF DOORS	CASTER SIZE	SHIP WT. LBS. (KG)
	44.25" (1124)	24.25" (616)	24.25" (616)	1	5"	205 (93)
	44.25" (1131)	24.5" (623)	24.75" (629)	1	5"	235 (93)

ELECTRICAL DATA		
VOLTS	120	220-240
WATTS	1625	1872
AMPS	13.5	7.8
HERTZ	60	60
PHASE	Single	Single
PLUG USA	5-15P*	6-15P
PLUG CANADA	5-20P	6-15P

*Dedicated Circuit



Faucet Temperature Control



Soap Cartridge and Battery



5 Gallon Fresh Water Tank



2.7 Gallon Water Heater



7 Gallon Wastewater Tank



HS-24-ES Maple Wood Stain Options



CONSTRUCTION. Heliarc welded, single unit construction of 20 gauge stainless steel with easy-to-clean coved corners. Front edge shall have raised marine nosing to contain water. Backsplash shall be 8.5" high.

DOORS AND LATCHES. Flush mounted, stainless steel door. Full length magnetic recessed workflow handle with locking cam latch. Heavy duty pin style hinges.

CASTERS. Maintenance-free polyurethane tire casters in a configuration of two (2) rigid and two (2) swivel with brake.

WATER CAPACITY. The unit shall include one (1) five gallon fresh water tank and one (1) seven gallon waste water tank. Electric water heater with adjustable thermostat provides a temperature range of 65°-145°F (19°-62°C) and heats up to 2.7 gallons of water. Glass insulated tank for thermal efficiency and fast recovery.

FAUCET CHARACTERISTICS. Faucet shall be motion activated and powered by four (4) AA Batteries. Faucet shall have a concealed thermostat control. Faucet water pressure shall be two (2) gallons per minute.

SOAP DISPENSER CHARACTERISTICS. Soap dispenser shall be motion activated and shall be powered by four (4) D batteries. Recommended soap refill: Rubbermaid FG4015411 800ml.

ELECTRICAL CHARACTERISTICS. 3 wire grounded 10 foot extension power cord and plug. HS-24 cord and plug are fed through right side cord exit. Alternative left side cord exit provided. HS-24-ES cord and plug are fed through the front of the unit only. See electrical data chart above for amperage and receptacle configuration.

INSTALLATION. Unit should not be installed in an area where adverse environmental conditions are present.

DOORS

Left hand door hinging

CASTERS

All swivel or larger casters

EXTRAS

Full perimeter bumper (HS-24 only)

Corner bumpers (HS-24 only)

Extra fresh water tank

Extra waste water tank

Graphic wrap (HS-24 only)

Protective storage cover

FOOD WARMING EQUIPMENT COMPANY, INC.

5599 HWY. 31 W. Portland, TN 37148

800-222-4393 | WWW.FWE.COM | SALES@FWE.COM

COOK | HOLD | TRANSPORT | SERVE | REFRIGERATION | BARS



FWE products may be covered under one or more of the following U.S. patents: 288,299; 238,300; 3,952,609; 4,192,991. All rights reserved. All specifications subject to change without notice. Errors subject to correction.
© 21 Food Warming Equipment Company, Inc. | R.21.01