

## INSULATED STAINLESS STEEL HOT CABINET MODEL H-138-S-1834D

### FEATURES AND BENEFITS:

- Fully insulated hot cabinet keeps prepared foods at serving temperatures.
- Powerful, yet efficient, 1500 Watt heating system maintains the right temperature to properly hold products. Heats up to 200°F (93°C).
- Standard solid state electronic control with large, clear, easy-to-read and operate LED digital display to ensure holding at precise food temperature
- Internal frame in body maintains structural rigidity.
- Stainless steel construction throughout for ease of cleaning. One piece extended base protects cabinet body.
- Smooth interior coved corners prevent food particles/grease buildup.
- Safety-conscious anti-microbial latches protect against spreading germs.
- Field reversible insulated Dutch doors prevent temperature loss. Silicone door gaskets for proper seal.
- Standard with right hand hinging; left hand hinging available upon request.
- High temperature ceramic magnetic latch for "easy open"; twist-lock catch secures door during transport.
- Recessed push/pull handles on both sides prevents damage to walls; allows easy maneuvering.
- Channel pan slides securely hold 18" x 26" pans on 1-1/2" centers without tipping.
- Heavy duty 5" swivel casters, two with brakes. Provides mobility when fully loaded.



H-138-S-1834D



Standard solid state electronic control with large, clear, easy-to-read and operate LED digital display to ensure holding at precise food temperature

### ACCESSORIES and OPTIONS

#### (Available at extra cost):

- Food Temperature Probe
- Tempered Glass Door Windows
- Key Lock Handle
- Lock Hasp
- Corner Bumpers
- Perimeter Bumper
- Floor Lock (for use with 5" casters)
- Various Caster Options
- Removable Cord Set
- 208 or 240 Volt Service
- Upgrade to 2000 Watt Power Unit

See page B-20 for accessory details.



# H-138-S-1834D

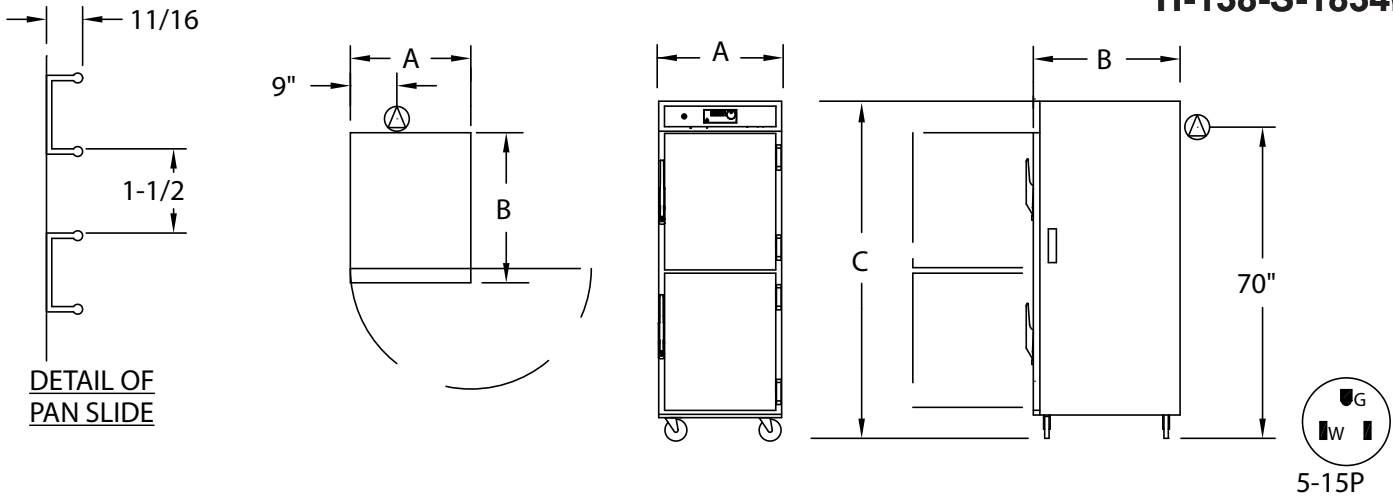

CRES COR MODEL NO.	PAN			DIM "A"	DIM "B"	DIM "C"	INSIDE DIMENSIONS				WEIGHT ACT.
	CAP	SIZE		WIDTH	DEPTH	HEIGHT	WIDTH	DEPTH	HEIGHT		
H-138-S-1834D	32	18 X 26	IN	28-3/4	32-3/4	73	18-1/16	26-7/8	58	LBS	272
		460 X 660	MM	730	835	1855	460	685	1475	KG	123

NOTES: 1. Send sample pan or tray with order when using any that are not 18" x 26" pans with heavy beaded edges.  
2. When ordering bumpers, add 2" to overall dimensions.



Gold indicates our Best Insulated Hot Cabinets with the best warranty in the industry.  
3-Year Parts / 1-Year Labor.

## CABINET:

- Body: 22 ga. stainless steel.
- Reinforcement: Internal framework of 18 ga. stainless steel.
- Insulation: Fiberglass, thermal conductivity (K factor) is .23 at 75°F. 1-1/2" in doors, top, base; 2" in sidewalls.
- Air tunnels: 22 ga. stainless steel; lift-out type, mounted on sides.
- Push/pull handles (2): 5" vertical; recessed.
- Interior coved corners.

## BASE:

- One piece construction, .125 aluminum.
- Casters: 5" dia., swivel, modulus tires, 1-1/4 wide, load cap. 250 lbs. each, temp. range -45°/+180°F. Delrin bearings. Front casters equipped with brakes.

## DUTCH DOORS:

- Field reversible.
- Formed 22 ga. stainless steel.
- Latches: Chrome plated zinc, high temperature ceramic magnetic type, mounted inboard.
- Transport Latches.
- Hinges: Heavy duty chrome plated zinc.
- Gaskets: Perimeter type, silicone.
- Pan stops: Embossed.

## PAN SLIDES:

- Channels: Extruded aluminum, 11/16 x 1-1/2 x .100, riveted on 1-1/2" centers.

## HOT UNIT COMPONENTS:

- Thermostat: Solid state digital display control, room ambient to 200°F (93°C).
- Switch: ON-OFF push button type.
- Power cord: Permanent, 10 ft., 14/3 ga.
- Heater: 1470 Watts.
- Blower motor.
- Vent Fan.
- Thermometer: Digital.

## POWER REQUIREMENTS:

- 1500 Watts, 120 Volts, 60 Hz., single phase, 12 Amps., 15 Amp. service.

## SHORT FORM SPECIFICATIONS

Cres Cor Insulated Hot Cabinet Model H-138-S-1834D. Solid state electronic controlled time and temperature. Cabinet 22 ga. stainless steel; stainless steel internal frame. No-tip .100 aluminum channel slides for (32) 18" x 26" pans on 1-1/2" centers. Field reversible Dutch doors, 22 ga. stainless steel. Fiberglass insulation in sides 2"; doors, top, base 1-1/2". Interior coved corners. 1500 Watt, 125 Volt power unit. One piece insulated base, .125 aluminum. 5" swivel modulus casters, Delrin bearings. Load capacity 250 lbs. each. 3-Year Parts / 1-Year Labor warranty. Provide the following accessories: \_\_\_\_\_  
\_\_\_\_\_ NSF, CSA-US, CSA-C listed. Energy Star Qualified.



5925 Heisley Road • Mentor, OH 44060-1833  
Phone: 877/CRESCOR • Fax: 440/350-7267  
www.crescor.com

© Crescent Metal Products, Inc. 2012 All rights reserved.

*In line with its policy to continually improve its products, CRES COR reserves the right to change materials and specifications without notice.*

Litho in U.S.A.