

INSULATED UNDERCOUNTER STAINLESS STEEL HOT CABINET MODEL H-137-SUA-5D

FEATURES AND BENEFITS:

- Fully insulated undercounter hot cabinet keeps prepared foods at serving temperatures.
- Powerful, yet efficient, 1000 Watt heating system maintains the right temperature to properly hold products. Heats up to 200°F (93°C).
- Standard solid state electronic control with large, clear, easy-to-read and operate LED digital display to ensure holding at precise food temperature.
- Internal frame in body maintains structural rigidity.
- Stainless steel construction throughout for ease of cleaning. One piece extended base protects cabinet body.
- Smooth interior coved corners prevent food particle/grease buildup.
- Safety-conscious anti-microbial latch protects against spreading germs.
- Field reversible insulated door prevents temperature loss; Silicone door gasket for proper seal.
- Standard with right hand hinging; left hand hinging available upon request.
- High temperature ceramic magnetic latch for "easy open"; twist-lock catch secures door during transport. Latch and hinges mounted inboard.
- Five sets of chrome plated wire universal angles accommodate a large variety of pan sizes on adjustable 1-1/2" centers.
- Heavy duty 2-1/2" swivel casters, two with brakes.
- Cabinets can be stacked for flexibility; specify optional stacking kit.



H-137-SUA-5D



Standard solid state electronic control with large, clear, easy-to-read and operate LED digital display to ensure holding at precise food temperature

ACCESSORIES and OPTIONS (Available at extra cost):

- Key Lock Handle
- Stacking Kit
- Bail Handles
- Extra Universal Angles
- Change from standard chrome plated wire angles to angles designed for transporting
- Interior for 18" x 26" pans
- Corner Bumpers
- Perimeter Bumper
- Leg Kit
- Various Caster Options
- Removable Cord Set
- 208 or 240 Volt Service
- HACCP Documentation (Built-in USB port)

See page B-20 for accessory details.



H-137-SUA-5D

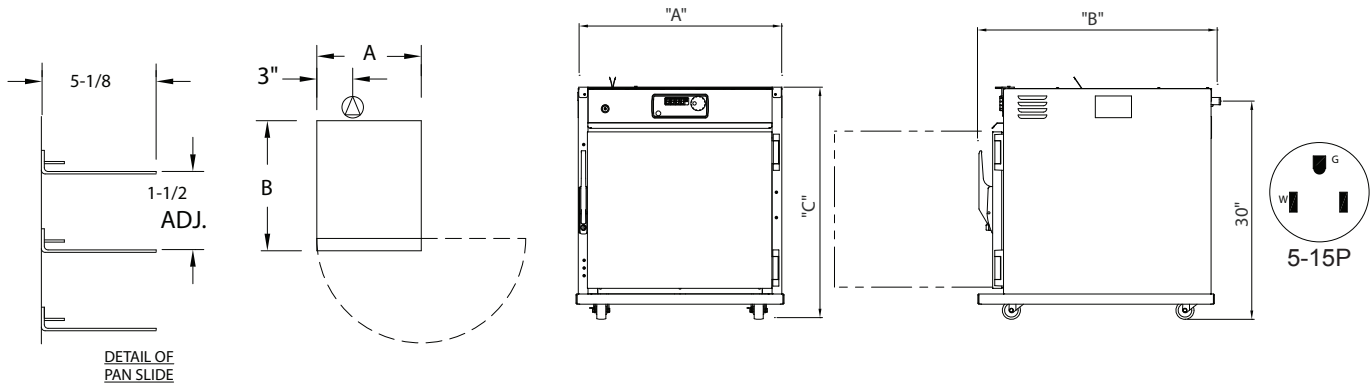

CRES COR MODEL NO.	PAN			DIM "A"	DIM "B"	DIM "C"	INSIDE DIMENSIONS			WEIGHT ACT.	
	CAP/ANGLES	SIZE		WIDTH	DEPTH	HEIGHT	WIDTH	DEPTH	HEIGHT		
H-137-SUA-5D	5 SETS	SEE NOTE BELOW	IN	28-1/4	33-3/8	31-3/4	22	26-3/4	19-1/2	LBS	184
			MM	720	850	810	560	670	450	KG	83

NOTES: 1. Pan sizes 22" x 20" (560 x 510) Roast & Bake Pans, 10" x 20" (255 x 510) Roast & Bake Pans, 18" x 26" (460 x 660) Bun Pans, 14" x 18" (355 x 460) Service Trays, 12" x 20" (305 x 510) Steam Table Pans.
Refer to Pan Size Chart at end of section.

2. When ordering bumpers, add 2" to overall dimensions.



Gold indicates our Best Insulated Hot Cabinets with the best warranty in the industry.
3-Year Parts / 1-Year Labor.

CABINET:

- Body: 22 ga. stainless steel.
- Reinforcement: Internal framework of 18 ga. stainless steel.
- Insulation: Fiberglass, thermal conductivity (K factor) is .23 at 75°F. 1-1/2" in door, base, top; 2" in sidewalls.
- Air tunnels: 22 ga. stainless steel; lift-out type, mounted on sides.
- Interior coved corners.

BASE:

- One piece construction, .125 aluminum.
- Casters: 2-1/2" dia., swivel, polyolefin tires, 1-1/8" wide, load cap. 150 lbs. each, temp. range -20°/+180°F. Plain bearings. Front casters equipped with brakes.

DOOR:

- Field reversible.
- Formed 22 ga. stainless steel.
- Latch: Chrome plated zinc, high temperature ceramic magnetic type, mounted inboard.
- Transport Latch.
- Hinges: Heavy duty chrome plated zinc.
- Gasket: Perimeter type, Silicone.
- Pan stop: Embossed.

PAN SLIDES:

- Wire angles (.306 dia.), nickel chrome plated steel, mounted on lift-off posts.
- Spaced on 3" centers; adjustable on 1-1/2" centers.

HOT UNIT COMPONENTS:

- Thermostat: Solid state digital display control, room ambient to 200°F (93°C).
- Switch: ON-OFF push button type.
- Power cord: Permanent, 10 ft., 14/3 ga.
- Heater: 960 Watts.
- Blower motor.
- Vent fan.
- Thermometer: Digital.

POWER REQUIREMENTS:

- 1000 Watts, 120 Volts, 60 Hz., single phase, 8 Amps., 15 Amp. service.

SHORT FORM SPECIFICATIONS

Cres Cor Insulated undercounter Hot Cabinet Model H-137-SUA-5D. Solid state electronic controlled time and temperatures. Cabinet 22 ga. stainless steel; stainless steel internal frame. (5) sets wire universal angles for multiple pan sizes, adjustable spacing every 1-1/2". Field reversible door, 22 ga. stainless steel. Fiberglass insulation in sides 2"; door, base, top 1-1/2". Interior coved corners. 1000 Watt, 120 Volt power unit. One piece insulated base, .125 aluminum. 2-1/2" swivel polyolefin casters, plain bearings. Load capacity 150 lbs. each. 3-Year Parts / 1-Year Labor warranty. Provide the following accessories: _____ . NSF, CSA-US, CSA-C listed.



5925 Heisley Road • Mentor, OH 44060-1833
Phone: 877/CRESCOR • Fax: 440/350-7267
www.crescor.com

© Crescent Metal Products, Inc. 2015 All rights reserved.

In line with its policy to continually improve its products, CRES COR reserves the right to change materials and specifications without notice.

Litho in U.S.A.