

Countertop Cooker & Warmer | CW



CW-100

From holding side dishes, soups, and entrées to creating new buffet lines, the Countertop Cooker & Warmer is a versatile piece of equipment for all types of operations in the foodservice industry. It provides greater menu flexibility and the ability to respond efficiently to changing menu requirements.

The Countertop Cooker & Warmer features an adjustable thermostat to hold a variety of different foods within the safety temperature guidelines. The unique design of the heating system features a tubular heating element attached to an aluminum plate, which provides even heat distribution throughout the unit in order to eliminate unappetizing hot or cold spots.

With a convenient drain located on the front of the unit, the Countertop Cooker & Warmer makes clean up at the end of the day quick, easy, and safe for operators.

FEATURES

- Ideal for holding side dishes, soups, and entrées.
- Heavy duty stainless steel construction.
- Adjustable thermostat with range of 120–212°F (49–100°C).
- Tubular heating element attached to aluminum plate to distribute heat evenly.
- Holds full-size inset pan or, with adaptor, several smaller inset pans.
- A convenient drain system allows for safe and easy cleaning at the end of the day.
- Temperature indicator settings: High, Medium, Low.
- UL, cUL, and NSF listing.

Countertop Cooker & Warmer | CW

Dimensions

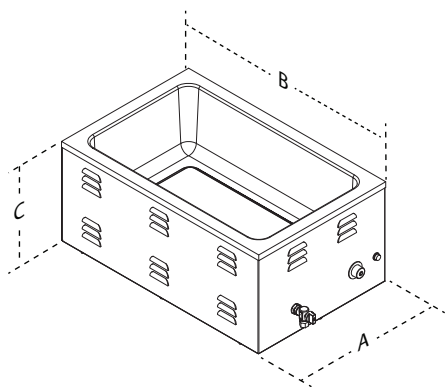

Model & Mfg. No.	Width (A)	Depth (B)	Height (C)
CW-100 9400158	14 5/8" (371 mm)	23 7/8" (607 mm)	10 1/2" (267 mm)
CW-127 9400159	14 5/8" (371 mm)	31 3/4" (806 mm)	10 1/2" (267 mm)

Electrical Ratings and Plug Configuration

Model & Mfg. No.	Volts	Watts	Amps	Hertz	Plug Description
CW-100 9400158	120	1500	12.5	60	NEMA 5-15P 15 Amp., 120 Volt
CW-127 9400159	120	1800	15	60	NEMA 5-15P 15 Amp., 120 Volt

Specifications

Model & Mfg. No.	Pre-heat Time to 180°F (82°C)
CW-100 9400158	15 min.
CW-127 9400159	

P/N 1020347 07/17