

Manual Convection Oven

model #: **6240**



DIMENSIONS

Equipment (w x d x h) 18" x 20¹/₄" x 19"
 Internal Cavity (w x d x h) 13³/₄" x 10⁵/₈" x 10¹/₄"
 Dimension Between Racks 2³/₄"
 Equipment Weight 42 lbs
 Shipping Weight. 49 lbs

CAPACITY

4- 13" x 9" Quarter Size Pans

Great for any size kitchen that needs to bake in small batches. This quarter size convection oven is perfect for maximizing cooking capacity in a tight space.

STANDARD FEATURES

- Set temperature from 200°F to 500°F
- Cooking time adjustable up to 2 hours or "infinite" time to adjust cooking duration
- Cooking option available: convection cooking
- Cooking chamber entirely made with stainless steel
- Oven shell entirely made with stainless steel
- Inspection door to facilitate cleaning operations
- Recessed gasket to guarantee chamber cooking seal



Manual Convection Oven

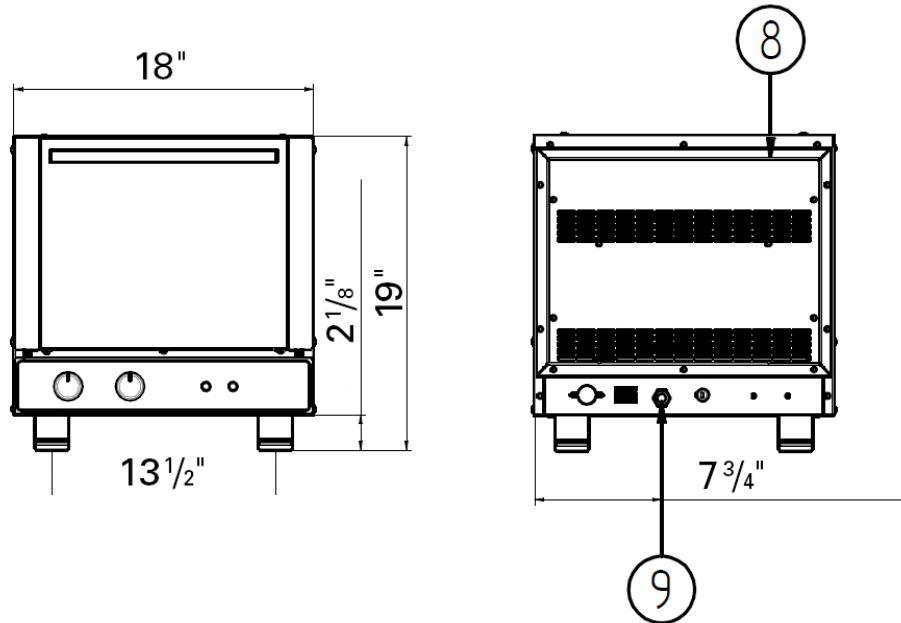

- 8. Steam Exhaust
- 9. Cable Gland for Power Supply

Model #	Description	Volts	Watts	Amps	Plug Configuration
6240	Manual Convection Oven, 1/4 Size, 4-Shelf	120	1700	14.2	NEMA 5-20P

INSTALLATION REQUIREMENTS:

- The oven must be positioned on a leveled surface
- Hot surfaces must comply with the minimum distances from the oven:

LEFT SIDE:	19 3/4"
RIGHT SIDE:	19 3/4"
REAR PANEL:	19 3/4"
- Other surfaces must comply with the minimum distances from the oven:

LEFT SIDE:	4"
RIGHT SIDE:	4"
REAR PANEL:	4"

