



Features

Eco-Friendly Refrigerant

R290 refrigerant with a global warming potential (GWP) of 3

High-Strength, Full-Extension Drawers

Premium slide and framework construction promotes lateral stability while offering high dynamic load capacities and a stay-shut feature

Stainless Steel Exterior

Galvanized back and bottom to reduce the risk of corrosion

Easy to Clean

Stainless steel interior, coved corners, finished edges, and easy lift-out drawers

Long-Lasting, Removable Gaskets

Santoprene™ gasket last four times longer than standard gaskets

Cold Wall Refrigeration System

Optimized temperature control thanks to the cold wall refrigeration

Drawer Capacity

Each drawer accommodates one (1) full-size 12" W x 20" H x 6" D hotel pan — additional adapters are available for fractional pans

High-Density Insulation

Foamed-in-place, CFC-free polyurethane insulation for maximum strength, rigidity, and insulation

Mobility

3" heavy-duty soft casters plus a sleek design allow for easy movement around the kitchen

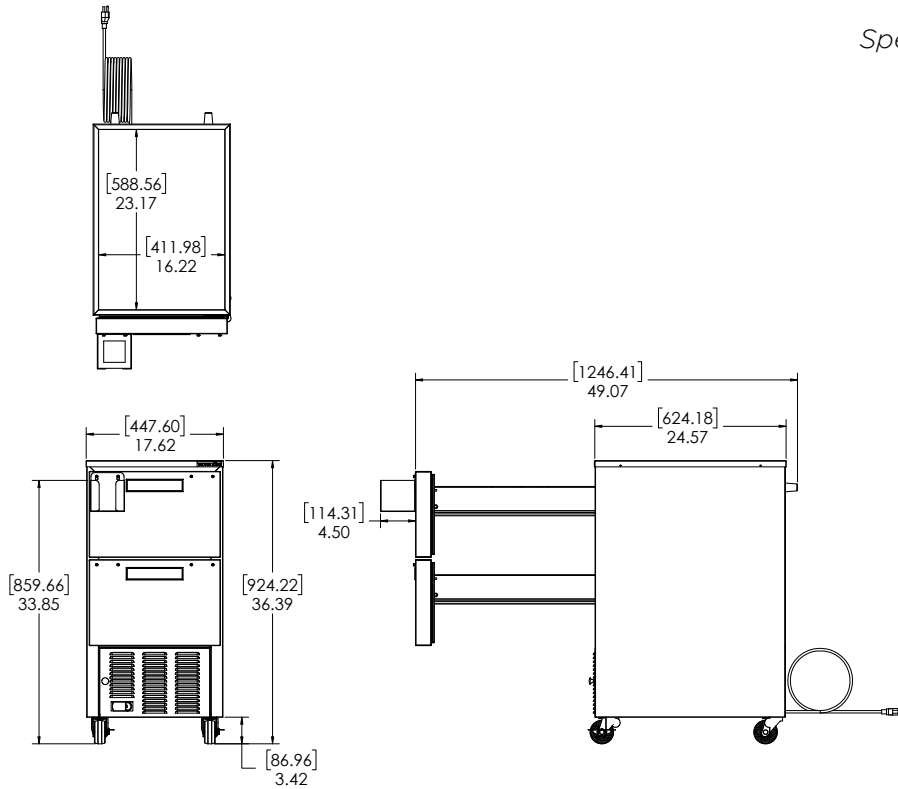

Technical Specifications

Electrical Requirements	115v/60hz/1ph/NEMA 5-15P Plug
Product Dimensions	17.62"W x 36.39"H x 32.92"D (44.75cm x 92.43cm x 83.62cm)
Product Weight	160lbs (72.57kg)
Shipping Dimensions	22"W x 45"H x 33"D (55.88cm x 114.30cm x 83.82cm)
Shipping Weight	175lbs (79.38kg)
Shipping Cubic Dimensions	18.91ft ³ (0.54m ³)
Refrigerant	R290
Charge Level	3.35oz (95 grams)

Temperature Range	36 to 40 (2.2 to 4.4°C)
Insulation	Foamed-in-place, CFC-free polyurethane
Exterior Construction	Stainless steel exterior with galvanized back and bottom
Interior Construction	Aluminum interior with coved corners and finished edges
Drawers	Two (2) high-strength, full-extension drawers
Drawer Capacity	Accommodates (2) full-size 12" W x 20" H x 6" D hotel pans
Drawer Gaskets	Santoprene™ gasket
Casters	Four (4) 3" heavy-duty soft casters (two locking)
Certifications	ETL Safety, ETL Sanitation
Warranty	1-year parts and labor, 5-year compressor (part only)

Model Number	Description
SKDL18-EDUS1	Cold holding Refrigerator 18", 115v/60hz/1ph, 2 drawer, 3" heavy-duty soft casters (two locking), NEMA 5-15P

Accessories	Description
25567	Adapter Bars for Fractional Pans
43581	Pan 1/6 Size, 4" Deep Plastic
43643	Pan 1/6 Size, 6" Deep Plastic
27066	Pan 1/3 Size, 4" Deep Plastic
26415	Pan 1/3 Size, 6" Deep Plastic

To learn more about **Cold Holding Refrigerator**, visit silverking.com