



## Features

### **Eco-Friendly Refrigerant**

R290 refrigerant with a global warming potential (GWP) of 3

### **High-Strength, Full-Extension Drawers**

Premium slide and framework construction promotes lateral stability while offering high dynamic load capacities and a stay-shut feature

### **Stainless Steel Exterior**

Galvanized back and bottom to reduce the risk of corrosion

### **Long-Lasting, Removable Gaskets**

Santorprene™ gaskets last four times longer than standard gaskets

### **Heavy-Duty Soft Casters**

Secured to a 12 gauge steel base to ensure years of worry-free operation

### **High-Efficiency Refrigeration System**

Forced air circulation provides uniform temperature throughout the cabinet while automatic defrost self-manages ice buildup and evaporates moisture

### **Drawer Capacity**

Large drawers include two (2) divider bars to accommodate three (3) full-size 12"W x 20"H x 6"D hotel pans. Small drawers include one (1) divider bar to accommodate two (2) full-size hotel pans — additional pan adapters are available for fractional pans

### **Easy to Clean**

Aluminum interior, coved corners, finished edges, plus full-extension and easy lift out drawers

### **High-Density Insulation**

Foamed-in-place, CFC-free polyurethane insulation for maximum strength, rigidity, and insulation

### **Flat Top with Backsplash**

3" backsplash provides a backstop for countertop equipment while protecting your walls

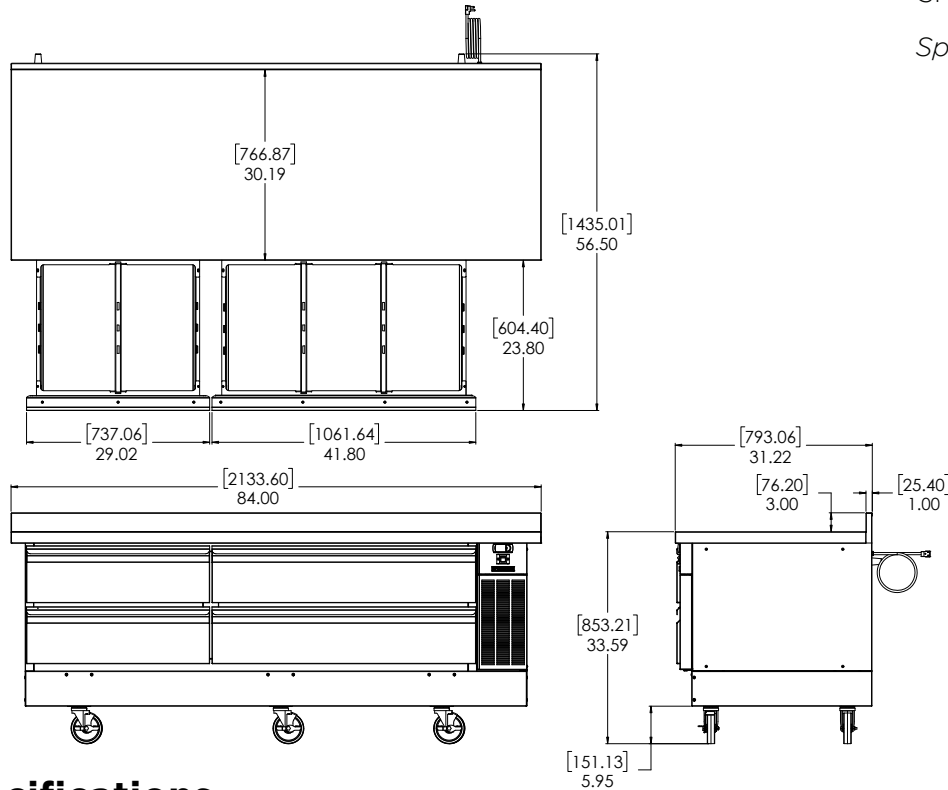

## Technical Specifications

<b>Electrical Requirements</b>	115v/60hz/1ph/NEMA 5-15P Plug
<b>Product Dimensions</b>	84"W x 36.59"H x 32.58"D (213.36cm x 92.94cm x 82.75cm)
<b>Product Weight</b>	575lbs (260.82kg)
<b>Shipping Dimensions</b>	89"W x 56"H x 36"D (226.06cm x 142.24cm x 91.44cm)
<b>Shipping Weight</b>	665lbs (301.64kg)
<b>Shipping Cubic Dimensions</b>	103.83ft <sup>3</sup> (2.94m <sup>3</sup> )
<b>Temperature Range</b>	-5 to 0°F (-20.5 to 17.7°C)
<b>Refrigerant</b>	R290
<b>Charge Level</b>	2.82oz (80 grams)
<b>Insulation</b>	CFC-free polyurethane foam-in-place insulation

<b>Exterior Construction</b>	Stainless steel exterior with galvanized back and bottom
<b>Interior Construction</b>	Aluminum interior with coved corners and finished edges
<b>Drawers</b>	Four (4) high-strength, full-extension drawers with dividers
<b>Capacity</b>	Ten (10) full-size 12"W x 20"H x 6"D hotel pans
<b>Door/Drawer Gasket</b>	Santoprene™ gasket
<b>Casters</b>	Six (6) 5" heavy-duty soft casters (three locking)
<b>Certifications</b>	ETL Safety, ETL Sanitation
<b>Warranty</b>	1-year parts and labor, 5-year compressor (part only)

Model Number	Description
SKFCB84H-EDUS2	Chef Base Freezer 84", 115v/60hz/1ph, flat top with backsplash, riser kit, 4 drawer, 5" medium-duty soft casters (three locking), NEMA 5-15P

Accessories	Description
25567	Adapter Bars for Fractional Pans
43581	Pan 1/6 Size, 4" Deep Plastic
43643	Pan 1/6 Size, 6" Deep Plastic
27066	Pan 1/3 Size, 4" Deep Plastic
26415	Pan 1/3 Size, 6" Deep Plastic

To learn more about **Chef Base Freezer**, visit [silverking.com](http://silverking.com)