



FEATURES

- Oil lubricated rotary vane vacuum pump, nominal speed 423 cf/h (12 m³/h);
- Vacuum level control through high precision absolute-type vacuum sensor, which does not require calibration;
- Maximum vacuum 99,8% (2 millibar);
- 12,2" sealing bar, easily removable for cleaning;
- Brilliant stainless steel vacuum chamber with constant thickness, easy to clean being free of edges and receptacles;
- Standard inert gas injection with 2 injection nozzles with "Gasplus" system, which allows to reach values up to 90% of inert gas for products extremely sensitive to crushing;
- Waterproof control panel, resistant to liquids, humidity, dirt and dust;
- 10 editable user programs;
- 1 cycle for vacuum containers;
- 1 deaeration "chef" cycle (Degas);
- "H2Out" pump oil dehumidification cycle;
- Resettable oil change alarm;
- Menu accessible to technical assistance for parameter adjustment and reading of cycles carried out;
- High-thickness blued PMMA (Plexiglass) lid with polished and rounded edges; opens automatically at the end of the cycle;
- Lowering system of the lid at the end of the work in the rest position by releasing the rear gas spring, which allows to release the tension on the gas spring and on the lid;
- Access for easy maintenance through front opening of the casing;
- Standard "Easy" accessory for external vacuum in embossed bags;
- 2 PE-filling plates for product adjustment and cycle speed up.

DESCRIPTION

The "31" model of the Idea line catches the eye for cutting-edge design. Ease of use and versatility make it an ideal work tool in every professional kitchen. Made entirely of AISI304 stainless steel, it stands out for its digital control panel with absolute vacuum sensor, inert gas injection and a "Degas" series cycle. Easy maintenance and cleaning are facilitated by the front opening of the machine body and the brilliant, rounded surfaces of the vacuum chamber.



SEALING BAR 12.2 inch
VACUUM PUMP 423 cf/h
ABSOLUTE SENSOR
CONTROL

ACCESSORIES (NOT INCLUDED)

- Bags for storage, cooking and "cook & chill"; embossed bags;
- Stainless steel cart with castors and shelf;
- Inclined stainless steel plate for liquid packing;
- Stainless steel vacuum containers; suction device.

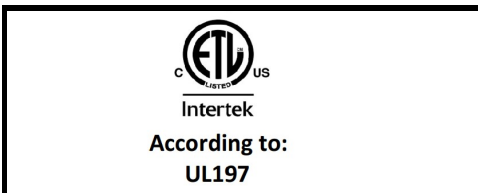

PROJECT	DATE	APPROVED
ITEM	QTY	

VACUUM PACKAGING MACHINES IDEA 31

UPDATED:
01/03/2022

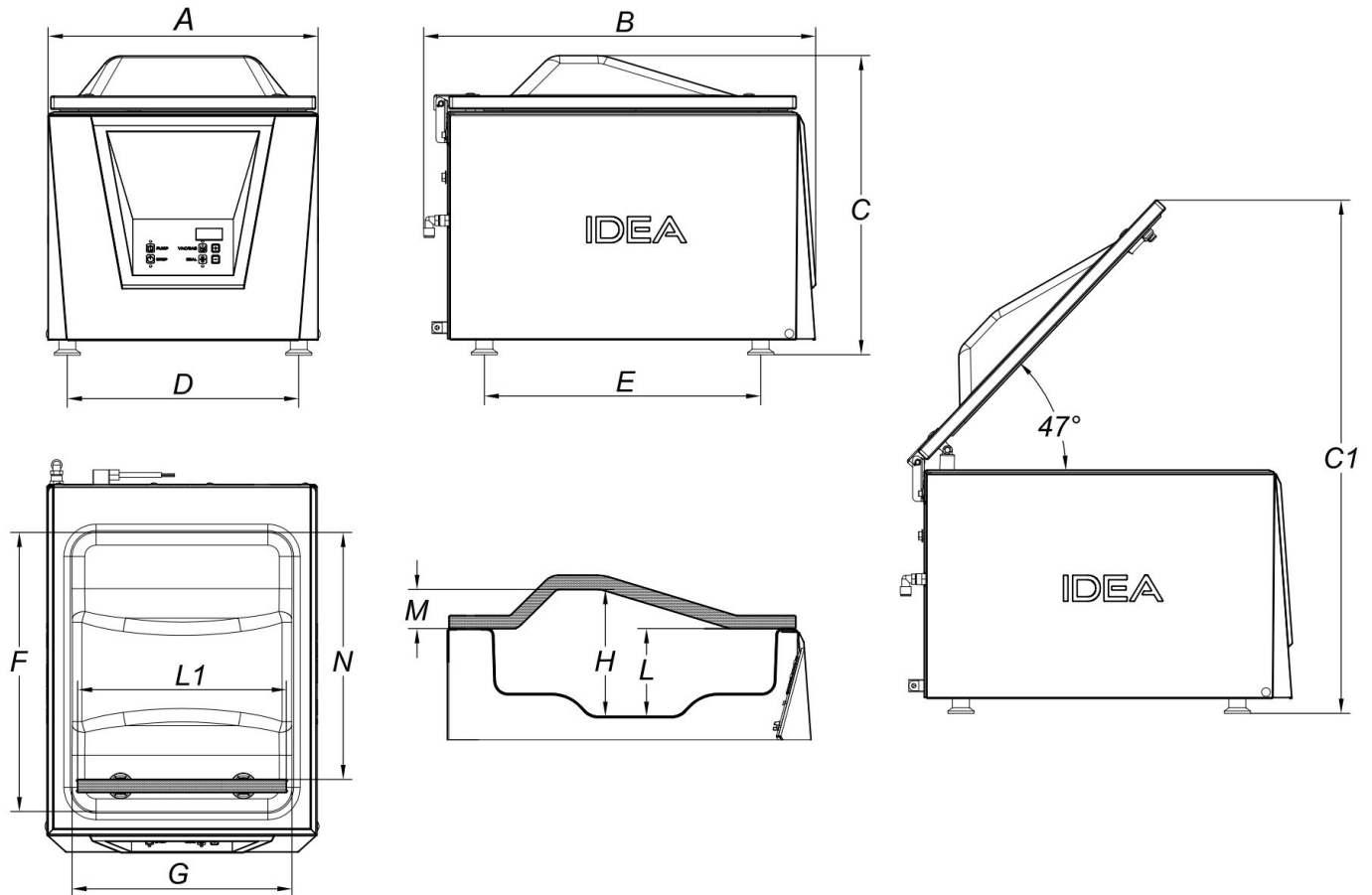

SPECIFICATIONS

Length of seal L1	inch	12,2
Nominal pump speed	cf/h	423
Final pressure	mbar	2
Chamber size (FxGxH)	inch	17,1x13,5x7,7
Useful chamber space (N)	inch	15
Chamber depth (L)	inch	5,3
Chamber volume	Usgal	5,02
Power	W	700
Electrical voltage/Frequency/Phases	V/Hz	110V / 60Hz / 1Ph+N+PE
Power cord and plug		78,7 inch + IEC / Nema 5
Current	A	6,36
Housing materials		Stainless steel (AISI304)
Vacuum chamber material		Hydroformed stainless steel (AISI304)
Lid material		PMMA (plexiglas)
Overall dimensions (AxBxC)	inch	16,3x23,7x18,1
Maximum height with open lid (C1)	inch	31,1
Distance between supports (DxE)	inch	14x16,7
Weight (with shelves)	lbs	102,1
Noise level	dB(A)	62
Environmental operating temperature (min-max)	°F	53,6-104