

DATA SHEET

DIRECT DRIVE PLUNGER PUMPS



Stainless Steel Models:

2SF05SEEL, 2SF10SEEL, 2SF15SEEL, 2SF22SEEL

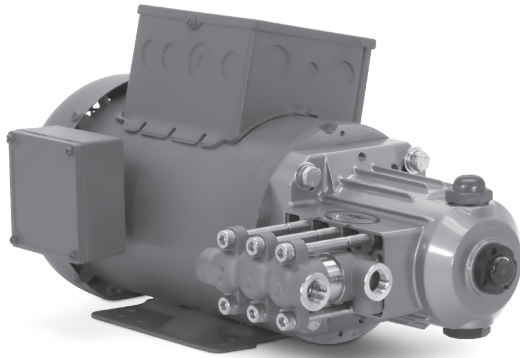

Motorized Pump Unit 2SF22SEEL Shown

FEATURES

- Unique spring-loaded inlet valves and flow-through ceramic plungers provide a smooth, steady flow.
- Hollow shaft direct-drive configuration provides the smallest possible footprint for confined spaces.
- Pump comes standard with NBR seals. Alternative seal materials are available for higher temperature or chemical compatibility.

SPECIFICATIONS	U.S. Measure	Metric Measure
Model 2SF05SEEL		
Flow	0.5 gpm	1.9 lpm
Stroke	0.071"	1.8 mm
Model 2SF10SEEL		
Flow	1.0 gpm	3.8 lpm
Stroke	0.122"	3.1 mm
Model 2SF15SEEL		
Flow	1.5 gpm	5.7 lpm
Stroke	0.177"	4.5 mm
Model 2SF22SEEL		
Flow	2.2 gpm	8.3 lpm
Stroke	0.248"	6.3 mm

COMMON SPECIFICATIONS	U.S.	Metric
Pressure Range	100–1200 psi	6.9–83 bar
Pump RPM	1725 rpm	1725 rpm
Inlet Pressure Range	Flooded to 60 psi	Flooded to 4.1 bar
Max. Liquid Temp. (NBR)	160° F	71° C
Alternative seals available for higher temperatures up to 180° F		
Bore	0.709"	18 mm
Crankcase Capacity	10.1 oz	0.30 l
Inlet Port	3/8" NPT(F)	3/8" NPT(F)
Discharge Ports (2)	3/8" NPT(F)	3/8" NPT(F)
Bypass Return Port	1/4" NPT(F)	1/4" NPT(F)
Shaft Diameter	5/8"	15.9 mm
Weight (Pump Only)	8.9 lbs	4 kg
Dimensions (Pump Only)	6.8 x 8.7 x 5.2"	173 x 221 x 133 mm

ALTERNATIVE SEAL CONFIGURATION

MATERIAL	SUFFIX CODE	MAXIMUM TEMPERATURE	
NBR	—	160° F	(71° C)
FPM	.0110	180° F	(82° C)
EPDM	.0220	160° F	(71° C)
FFKM	.0770	180° F	(82° C)
HT	.3000	180° F	(82° C)

See **Tech Bulletin 002** for inlet conditions and RPM at high temperature.

$$\frac{\text{DETERMINING THE PUMP RPM}}{\text{Rated rpm}} = \frac{\text{Desired gpm}}{\text{Desired rpm}}$$

$$\frac{\text{DETERMINING THE REQUIRED HP}}{\text{(Electric Brake)}} = \frac{\text{gpm} \times \text{psi}}{1460}$$

Refer to pump **Service Manual** for repair procedure and additional technical information.

PARTS LIST

ITEM	PART NUMBER	MATL	DESCRIPTION	MODEL	QTY
5	547445	S	Screw, HHC Sems (M6 x 14) (See Tech Bulletins 074, 092)	All	3
8	547153	AL	Cover, Bearing (See Tech Bulletin 092)	All	1
10	14041	NBR	O-Ring, Bearing Cover-70D (See Tech Bulletin 092)	All	1
11	55337	NBR	Seal, Oil, Crankshaft (See Tech Bulletin 092)	All	1
15	14488	STL	Bearing, Ball, Inner	All	1
20	547046	TNM	Rod, Connecting	All	3
25	831987	CM	Crankshaft (M1.8)	05SEEL	1
	46109	CM	Crankshaft (M3.1)	10SEEL	1
	44931	CM	Crankshaft (M4.5)	15SEEL	1
	45160	CM	Crankshaft (M6.3)	22SEEL	1
26	12385	STL	Ring, Retaining, Bearing	All	1
27	15710	STL	Bearing, Ball, Outer	All	1
32	547961	RTP	Cap, Oil Filler with O-Ring	All	1
33	14179	NBR	O-Ring, Oil Filler Cap-70D	All	1
37	92241	PC	Gauge, Oil with Gasket-80D (See Tech Bulletin 074)	All	1
38	44428	NBR	Gasket, Flat, Oil Gauge-80D	All	1
48	44842	NY	Plug, Drain	All	1
49	14179	NBR	O-Ring, Drain Plug-70D	All	1
53	547285	AL	Crankcase (See Tech Bulletin 092)	All	1
64	16948	CM	Pin, Crosshead	All	3
65	834203	SSTO	Rod, Plunger (See Tech Bulletin 124)	All	3
69	126259	STCP R	Washer, Oil Seal	All	3
70	25461	NBR	Seal, Oil Crankcase	All	3
90	544697	CC	Plunger, Ceramic (M18 x 18)	All	3
100	44869	PVDF	Retainer, Seal	All	3
106	547683	NBR	Seal, Low-Pressure with SS-Spring	All	3
110	547704	SS	Manifold, Inlet	All	1
125	44652	SNG	Seal, High-Pressure with SS-Support	All	3
134	543691	SS	Valve, Inlet (See Tech Bulletin 091)	All	3
135	543689	SS	Spacer	All	3
136	543690	SS	Spring, Inlet Valve	All	3
137	88575	S	Washer, Conical (M6)	All	3
138	543692	SS	Nut (M6)	All	3
152	† 26089	NBR	O-Ring, Adapter Spacer, Inner-80D	All	3
157	544700	SS	Adapter, Valve	All	3
159	† 26089	NBR	O-Ring, Adapter Spacer, Outer-80D	All	3
164	544293	SS	Seat	All	3
166	543669	SS	Valve	All	3
167	543700	SS	Spring	All	3
168	44565	PVDF	Retainer, Spring	All	3
185	547705	SS	Manifold, Discharge	All	1
188	544701	S	Screw, HSH (M8 x 80) (See Tech Bulletin 074)	All	6
255	30517	STZP R	Assembly, Bolt Mount	All	1

Bold print part numbers are unique to a particular pump model. † Production parts are different than repair parts.

R Components comply with RoHS Directive. For additional technical information see www.catpumps.com/literature/tech-bulletins.

NOTE: Discard Key that may come standard with most motors and engines and use only the key included in Bolt kit. MATERIAL CODES (Not Part of Part Number):

AL=Aluminum CC=Ceramic CM=Chrome-Moly D=Acetal EPDM=Ethylene Propylene Diene Monomer FFKM=Perfluoroelastomer

FPM=Fluorocarbon HT=Hi-Temp (EPDM Alternative) NBR=Medium Nitrile (Buna-N) NY=Nylon PC=Poly Carbonate

PVDF=Polyvinylidene Fluoride RTP=Reinforced Composite S=304SS SNG=Special Blend (Buna)

SS=316SS SSTO=316SS/Titanium Oxide ST=Special PTFE ST4=Special PTFE 4 STL=Steel

STCP=Steel/Chrome Plated STZP=Steel/ZincPlated TNM=Special High Strength

Optional Parts and Accessories and Service Parts listed on page 3. Standard and optional Seal and Valve Kits listed on page 4.

EXPLODED VIEW

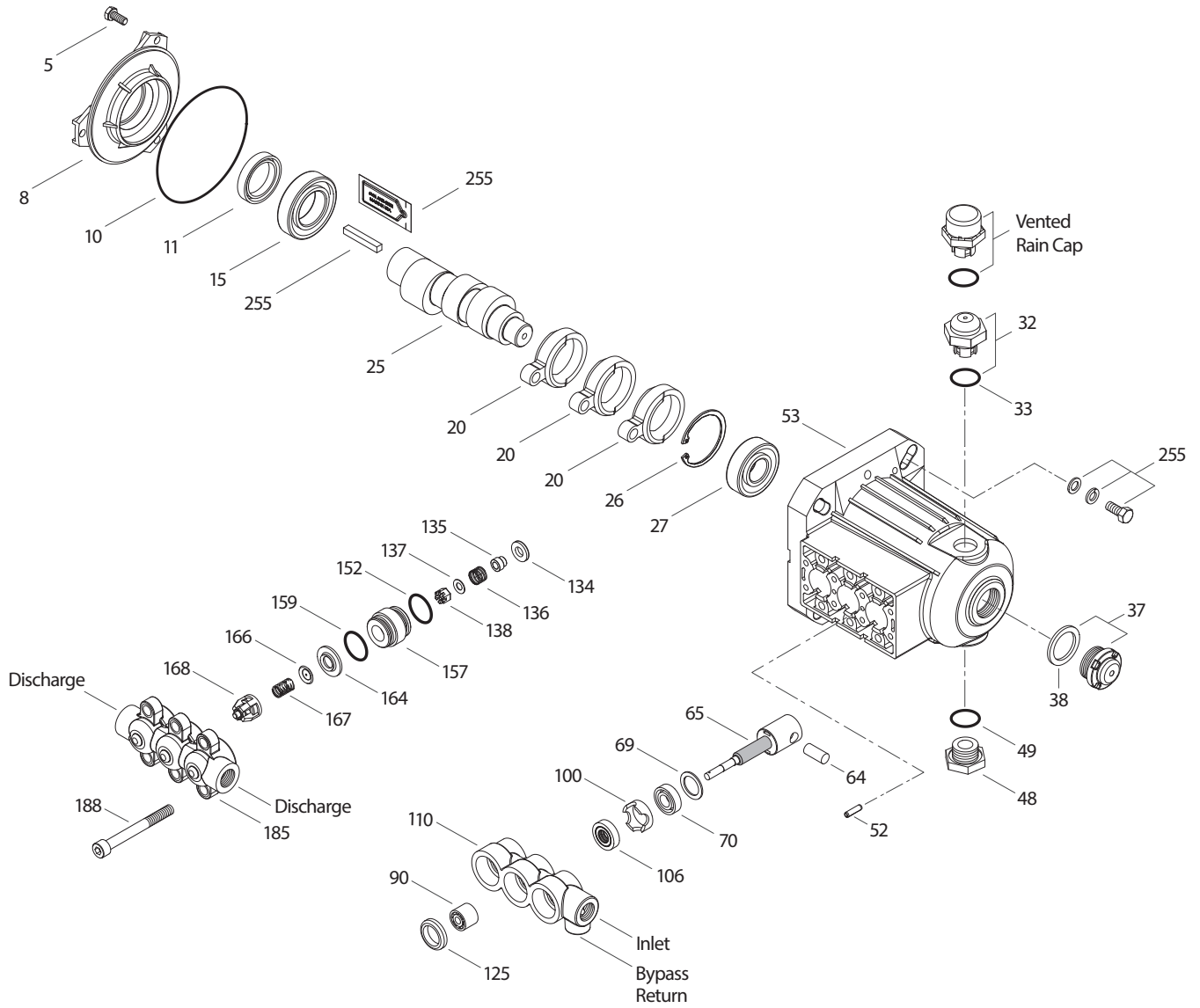

Models
2SF05SEEL, 2SF10SEEL,
2SF15SEEL, 2SF22SEEL
September 2024

OPTIONAL PARTS AND ACCESSORIES

PART	DESCRIPTION	QTY
549726	Cap, Vented with O-Ring (Rain Cap)	1
80228	Screw, HH (M8 – 1.25 x 80 Full Thread) (See Tech Bulletin 055)	2
7501	Unloader, 3/8" Ports, 316SS (Not Shown)	1
7501.100	Regulator, 3/8" Ports, 316SS (Not Shown)	1
9960	Valve, Pop-Off, 1/4" Port, 316SS (Not Shown)	1
990394	Kit, Oil Drain (Not Shown)	1

SERVICE PARTS

PART	DESCRIPTION	QTY
34973	Seal Kit – Standard NBR	1
34972	Discharge Valve Kit – Standard NBR	1
39668	Inlet Valve Kit – Standard NBR	1
6107	Oil, Bottle (21 oz) ISO 68 Hydraulic (Fill to Specified Crankcase Capacity Prior to Start-up)	1
6139	Lubricant, Anti-Seize (8 oz) (See Tech Bulletin 095)	1

SEAL KITS One (1) seal kit required per pump

PUMP MODELS	NBR (STD)	FPM (.0110)	EPDM (.0220) ◆	FFKM (.0770)	HT (.3000)
2SF05SEEL, 2SF10SEEL, 2SF15SEEL, 2SF22SEEL	34973	33453	30536*	76969	32210

ITEM (Included in Seal Kits)						DESCRIPTION	QTY
106	547683	545192	546507	76443 ¹	547683	Seal, Low-Pressure with SS-Spring	3
125	44652	46652	46652	76052 ²	46652	Seal, High-Pressure with SS-Support	3
152	26089	11377	46647	703244	26089	O-Ring, Adapter Spacer, Inner	3
159	26089	11377	46647	703244	26089	O-Ring, Adapter Spacer, Outer	3

◆ Silicone oil/grease required *Review material codes for individual items (SNG, HT, ST4 may be used as an alternative)

1 = ST2 Material

2 = ST4 Material

DISCHARGE VALVE KITS One (1) valve kit required per pump

PUMP MODELS	NBR (STD)	FPM (.0110)	EPDM (.0220) ◆	FFKM (.0770)	HT (.3000)
2SF05SEEL, 2SF10SEEL, 2SF15SEEL, 2SF22SEEL	34972	33454	30546	76596	34972

ITEM (Included in Valve Kits)						DESCRIPTION	QTY
152	26089	11377	46647	703244	26089	O-Ring, Adapter Spacer, Inner	3
159	26089	11377	46647	703244	26089	O-Ring, Adapter Spacer, Outer	3
164	544293	544293	544293	544293	544293	Seat	3
166	543669	543669	543669	543669	543669	Valve	3
167	543700	543700	543700	543700	543700	Spring	3
168	44565	44565	44565	44565	44565	Retainer, Spring	3

◆ Silicone oil/grease required

INLET VALVE KITS One (1) valve kit required per pump

PUMP MODELS	NBR (STD)	FPM (.0110)	EPDM (.0220) ◆	FFKM (.0770)	HT (.3000)
2SF05SEEL, 2SF10SEEL, 2SF15SEEL, 2SF22SEEL	39668	33460	30556	76586	39668

ITEM (Included in Valve Kits)						DESCRIPTION	QTY
134	543691 ¹	33873 ²	543691 ¹	543691 ¹	543691 ¹	Valve, Inlet	3
135	543689	543689	543689	543689	543689	Spacer	3
136	543690	543690	543690	543690	543690	Spring	3
137	88575	88575	88575	88575	88575	Washer, Conical	3
138	543692	543692	543692	543692	543692	Nut	3
152	26089	11377	46647	703244	26089	O-Ring, Adapter Spacer, Inner	3
159	26089	11377	46647	703244	26089	O-Ring, Adapter Spacer, Outer	3

◆ Silicone oil/grease required

1 = 316SS Material

2 = Acetal Material

MOTOR DIMENSIONS

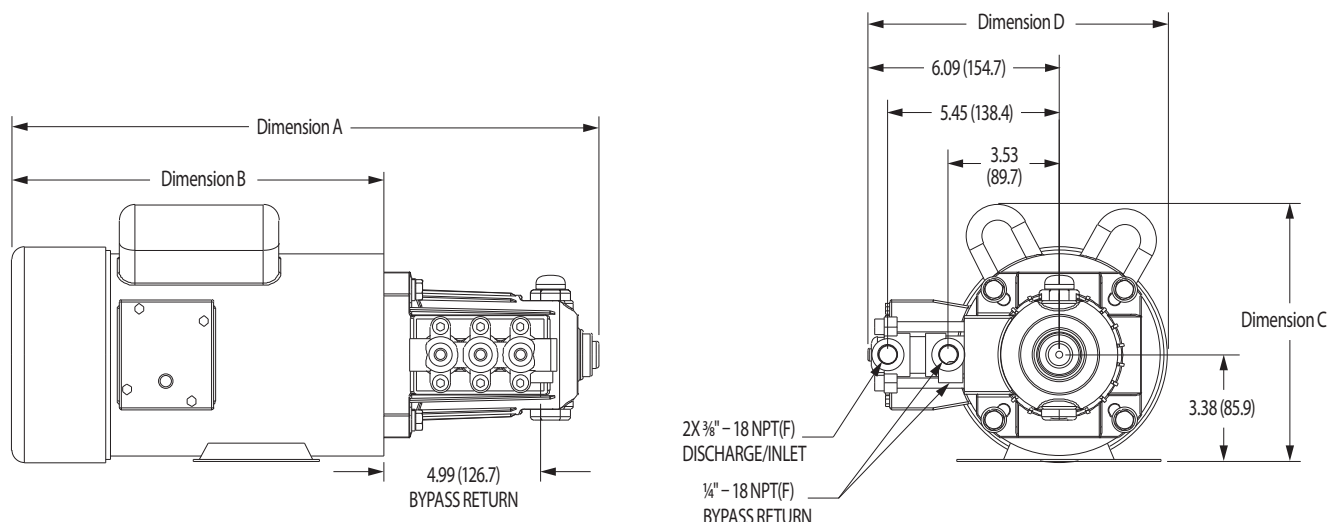

MODEL	8105	8175	8110	8115	8120	8125/8125W
Dimension A	15.9	15.9	17.1	19.3	19.3	19.3
Dimension B	9.0	9.0	10.2	12.4	12.4	12.4
Dimension C	8.2	8.2	8.2	9.7	9.7	9.7
Dimension D	9.1	9.1	9.1	9.7	9.7	9.7

MOTOR SPECIFICATIONS

MODEL	8105	8175	8110	8115	8120	8125/8125W
Horsepower	0.5	0.75	1.0	1.5	2.0	2.5
Phase	Single	Single	Single	Single	Single	Single
RPM	1750	1745	1750	1750	1750	1750
Frame Size	56C TEFC	56C TEFC	56C TEFC	56HC TEFC	56HC TEFC	56HC TEFC
Shaft Diameter	5/8"	5/8"	5/8"	5/8"	5/8"	5/8"
Maximum Volts	115/*230	115/*230	115/*230	115/208–230	115/208–230	115/208–230
Full Load Amps	7.4/3.7	10.6/5.3	14/7.0	13.8/7.63–6.90	17.2/9.53–8.62	20.8/10.4
Hertz	60	60	60	60/50	60/50	60/50
Service Factor	1.15	1.15	1.15	1.85	1.40	1.15
Max. Ambient Temperature	104° F	104° F	104° F	104° F	104° F	104° F
Capacitor Start	Yes	Yes	Yes	Yes	Yes	Yes
Thermal Overload-Manual Reset	No	Yes	No	No	No	No
Weight (lbs)	25	28	34	53.8	53.8	53.8

Notes:

1. Motor start-up Amps may vary, then settle within Full Load Amps rating after initial run time.
2. Refer to Tech Bulletin 136 for complete specifications for 50 Hz versions of Models 8115 and 8120.
3. Before mounting pump on motor, apply an antiseize lubricant (or PN 6106) to pump shaft.
4. Refer to Tech Bulletin 055 for instructions on removing pump from electric motor.
5. For electric motor warranty consideration, contact motor manufacturer's local Authorized Service Center.
6. * Prior to Department of Energy (DOE) EERE-2020-BT-TP-0011 motor was name-plated rated 208–230 Volt

⚠ CAUTIONS AND WARNINGS

All high-pressure systems require a primary pressure regulating device (e.g. regulator, unloader) and a secondary pressure relief device (e.g. pop-off valve, relief valve). Failure to install such relief devices could result in personal injury or damage to pump or property. Cat Pumps does not assume any liability or responsibility for the operation of a customer's high-pressure system. Read all CAUTIONS and WARNINGS before commencing service or operation of any high-pressure system. The CAUTIONS and WARNINGS are included in each Service Manual and with each Accessory Data sheet. CAUTIONS and WARNINGS can also be viewed online at www.catpumps.com/dynamic-literature/cautions-and-warnings or can be requested directly from Cat Pumps.

WARRANTY

View the Limited Warranty online at www.catpumps.com/literature/cat-pumps-limited-warranty