

# NL-PRO SERIES

*Reverse Osmosis System User Manual*

# TABLE OF CONTENTS

Safety	1
Operating Do's and Don'ts	1
Operating Limits	2
System Specification Chart	3
Component Identification	4
Pre-filtration	5
Component Descriptions	6
Membrane Information	7
Membrane Warranty	8
Membrane Performance	9
System Installation	10
Membrane Installation and Handling	11-12
System Purging/Initial Start Up	13
General Maintenance and Storage	14
Temperature Correction Factors	15
Temperature Correction Table	16
Reverse Osmosis Operating Log	17
Troubleshooting	18
NL-PRO 2000 Flow Diagram	19
NL-PRO 4000 Flow Diagram	20
NL-PRO 2000-4000 110V Electrical Diagram	21
NL-PRO 2000-4000 220V Electrical Diagram	22
System Warranty	23-24



**The NL-PRO Series Reverse Osmosis System** is a durable piece of equipment which, with proper care, will last for many years. This User Manual outlines installation, operation, maintenance and troubleshooting details vital to the sustained performance of your system.

If the feedwater conditions change, please contact your local dealer or distributor.

## PLEASE NOTE

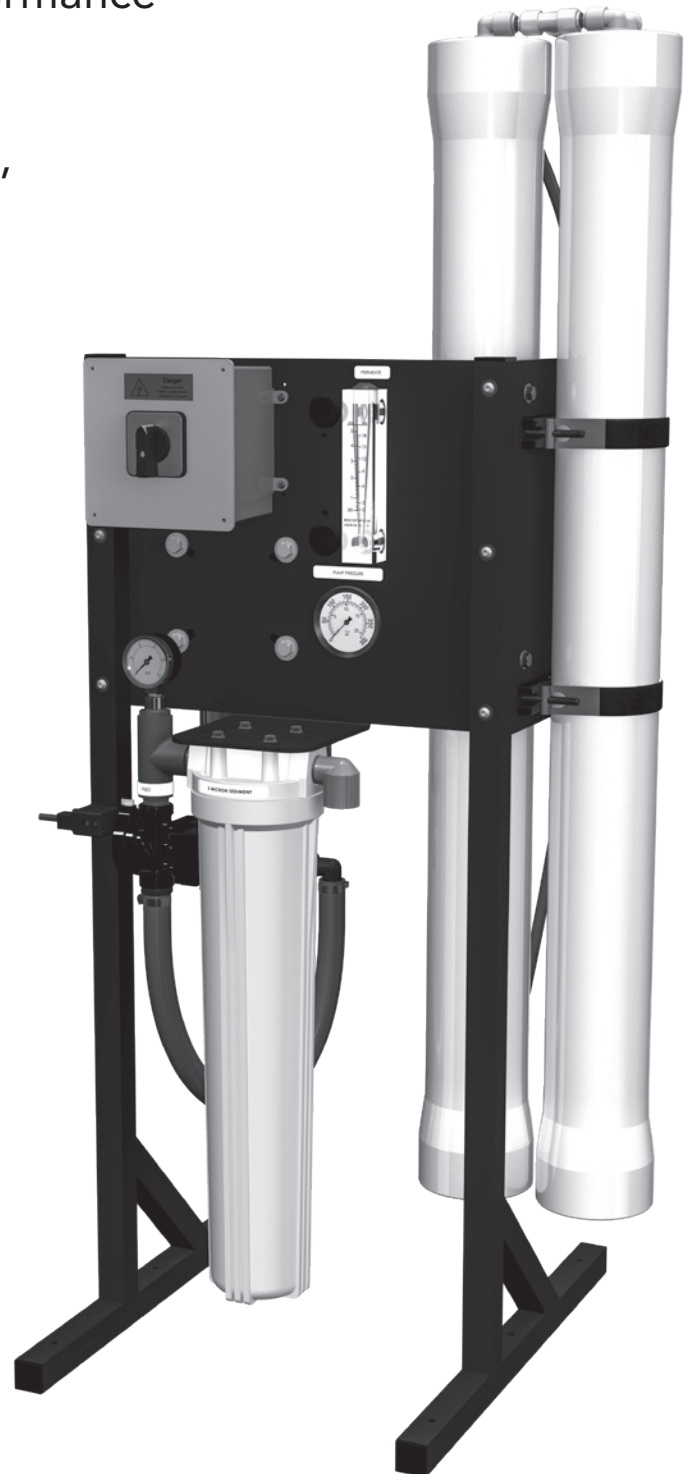

- Membrane elements do not come pre-loaded. Install membranes in accordance with this manual before beginning operation.
- Do not under any circumstance remove any caution, warning, or other descriptive labels from the system.
- Prior to operating or servicing the reverse osmosis system, this user's manual must be read and fully understood. Keep this and other associated information near the system for future reference.
- In order to maintain the manufacturer's warranty, an operating log must be maintained. Copies will need to be sent to your local dealer or distributor for review in the event of a warranty coverage issue.









## SAFETY

Defined below are the three safety headings used throughout this User Manual's text. Statements are advisory or informational statements of particular importance to the heading under which they are found.

### Warning Labels

	<b>Warning:</b> Indicates statements that are used to identify conditions or practices that could result in injury or loss of life. Failure to follow warnings could result in serious injury or even death.
	<b>Caution:</b> Indicates statements that are used to identify conditions or practices that could result in equipment or other property damage.
	<b>Electrical Hazard:</b> Indicates statements that are used to identify high-voltage and potential shock/electrocution.

### Precautions

	Do not use where the water is microbiologically unsafe or of unknown quality without adequate testing and disinfection before or after the system.
	Always turn off the unit, shut off the feedwater, relieve pressure, and disconnect the electrical power before working on the unit.
	Do not close the concentrate completely.
	Pre-treatment must be sufficient to eliminate chemicals, organics or inorganics that could attack the membrane material.
	Never allow the unit to freeze or operate with a feedwater temperature above 85°F.
	Do not permit chlorine to be present in the feed water.

## OPERATING DO'S AND DON'TS

### Do:

- Change the cartridge filters regularly.
- Monitor the system and keep a daily log.
- Run the system as much as possible on a continuous basis.

### Don't:

- Permit chlorine to enter or be present in the feed water.
- Shut down the system for extended periods.
- Operate the system with insufficient feed flow or pressure.

# OPERATING LIMITS

Nothing has a greater effect on a reverse osmosis system than the feed water quality. If the feed water conditions change, please contact your local dealer or distributor. Before starting the RO system it is strongly suggested to obtain an up to date water analysis of the water to be treated.



**It is very important to meet the minimum feed water and operating requirements outlined in this manual.** Failure to do so will cause damage or failure of the system components and membranes. Damage to the system due to operation outside of the specifications outlined in this manual will void the manufacturer's warranty. Check your feed water chemistry and, if necessary, consult with your local dealer or distributor before start up of the system.

## OPERATING LIMITS<sup>A</sup>

<b>Design Temperature (°F)</b>	77
<b>Maximum Feed Temperature (°F)</b>	85
<b>Minimum Feed Temperature (°F)<sup>B</sup></b>	40
<b>Maximum Ambient Temperature (°F)</b>	120
<b>Minimum Ambient Temperature (°F)</b>	40
<b>Maximum Feed Pressure (psi)</b>	80
<b>Minimum Feed Pressure (psi)</b>	45
<b>Maximum Operating Pressure (psi)</b>	200
<b>Operating Range (psi)</b>	70-130
<b>Maximum SDI Rating</b>	< 3
<b>Maximum Turbidity (NTU)</b>	< 1
<b>Maximum Free Chlorine (ppm)</b>	< 0
<b>Maximum TDS (ppm)<sup>C</sup></b>	2,000
<b>Maximum Hardness (gpg)</b>	0
<b>Maximum pH (continuous)</b>	10
<b>Minimum pH (continuous)</b>	4
<b>Maximum pH (cleaning 30 minutes)</b>	12
<b>Minimum pH (cleaning 30 minutes)</b>	2



Higher TDS and/or lower temperatures will reduce the system's production.



Do not exceed the maximum operating pressure.

- A. If any of the feed water parameters are not within the limits given, consult your local dealer or distributor for assistance.
- B. System Operating Pressure is based on 45 psi feed pressure, minimum concentrate flow as stated, and an average of 2,000 GPD flow per membrane at 77 °F.
- C. Low temperatures and feedwater quality, such as high TDS levels, will significantly affect the system's production capabilities and performance. Computer projections must be run for individual applications which do not meet or exceed minimum and maximum operating limits for such conditions.

# SYSTEM SPECIFICATION CHART

MODELS	NL-PRO 2000	NL-PRO 4000
<b>Design</b>		
Configuration	Single Pass	Single Pass
Feedwater TDS max (ppm) <sup>A</sup>	2,000	2,000
Standard Recovery %	32	46
<b>Flow Rates<sup>B</sup></b>		
Permeate Flow Rate (gpd / lpd)	2,000 / 7,570	4,000 / 15,141
Permeate Flow Rate (gpm / lpm)	1.39 / 5.26	2.78 / 10.52
Minimum Concentrate Flow (gpm / lpm)	3 / 11.36	3 / 11.36
<b>Connections</b>		
Feed (in)	3/4 FNPT	3/4 FNPT
Permeate (in)	1/2 QC	1/2 QC
Concentrate (in)	1/2 QC	1/2 QC
<b>Membranes</b>		
Membrane(s) Per Vessel	1	1
Membrane Quantity	1	2
Membrane Size	4040	4040
Nominal TDS Rejection %	98	98
<b>Vessels</b>		
Vessel Array	1	1:1
Vessel Quantity	1	2
<b>Pumps</b>		
Pump Type	Multi-Stage	Multi-Stage
Motor HP	1.0	1.0
RPM at 60 Hz	3480	3480
<b>System Electrical</b>		
Standard Voltage and Amp Draw <sup>C</sup>	110V, 60HZ, 1PH, 10.6A 220V, 60HZ, 1PH, 5.4A	110V, 60HZ, 1PH, 10.6A 220V, 60HZ, 1PH, 5.4A
<b>System Dimensions</b>		
Approximate Dimensions <sup>D</sup> L x W x H (in / cm)	18 x 22 x 55 / 45.72 x 55.29 x 138.39	23 x 22 x 55 / 58.17 x 55.29 x 138.39
Approximate Weight (lbs / kg)	100/45	110/50

- A. Low temperatures and feedwater quality, such as high TDS levels, will significantly affect the system's production capabilities and performance. Computer projections must be run for individual applications which do not meet or exceed minimum and maximum operating limits for such conditions.
- B. Product flow and maximum recovery rates are based on feedwater conditions as stated above. Do not exceed recommended permeate flow.
- C. Varies with motor manufacturer.
- D. Does not include operating space requirements.

## COMPONENT IDENTIFICATION

- ① Housing, Filter, Wht/Wht, 2.5" X 20", SGL O-Ring, Npr, 3/4" FNPT, SFH25, AXEON (Part #207404)
- ② Cartridge, Depth Filter, Polypropylene, 2.5" X 20", 5 Mic, SDF-25-2005, AXEON (Part #200626)
- ③ Switch, Rotary, 3-Position, DPDT (Part #212480) **OR** Switch, Rotary, 3-Position, 4 Poles (Part #212489)
- ④ Switch, Pressure, Low, 1/4" FNPT (Part #200906)
- ⑤ Pump, CM1-6, 1HP, 115/230V 60HZ 1PH, 304ss, 981257 (Part #211076)
- ⑥ Valve, Check, PVC, 1/2" FNPT X 1/2" FNPT (Part #200965)
- ⑦ Housing, Membrane, FRP-300E, 4040, 1/2" P X 1/2" C FNPT, AXEON (Part #209853)
- ⑧ Membrane, XE3, 4040, Dry, AXEON (Part #212285)
- ⑨ Meter, Flow, Pm, 0.5-5 gpm, 1/2" MNPT X 1/4" FNPT, AXEON (Part #200898)
- ⑩ Gauge, BKM, Fill, 0-300 Psi/Bar, 2.5" Dia, 1/4" MNPT, AXEON (Part #200904)
- ⑪ Valve, Solenoid, N/C, UI, 110V, 3/4" FNPT, NO DIN, GC (Part #204911) **OR** Valve, Solenoid, N/C, UI, 220V, 3/4" FNPT, NO DIN, GC (Part #204912)
- ⑫ Gauge, BTM, No Fill, 0-100 Psi/Bar, 2" Dia, 1/4" MNPT, AXEON (Part #205802)

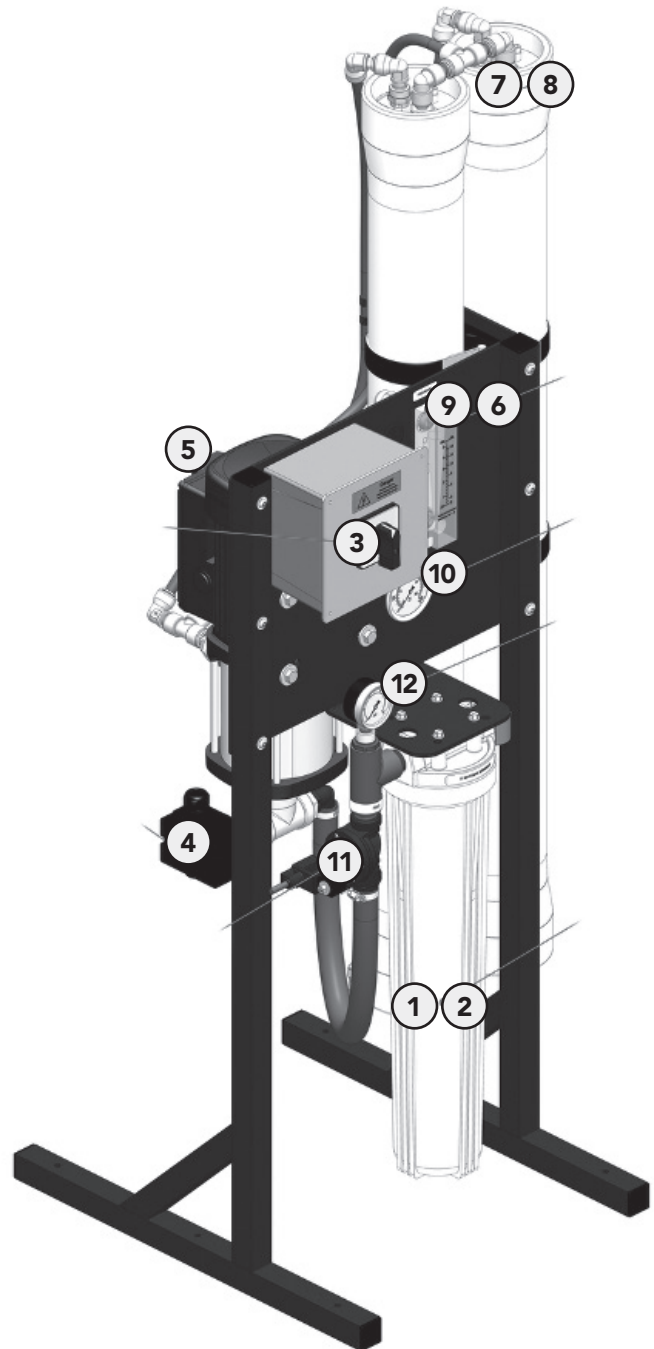

## PRE-FILTRATION

NL-PRO Series systems are supplied with a 5-micron sediment filter. Change the filtration cartridge when a 10-15 psi differential exists between the inlet pressure and filter out pressure.



The system must be operated on filtered water only.



**FILTER OUT**

### Pre-filtration Pressure Gauge

This gauge measures the pressure when it exits the pre-filter. A pressure differential of 10-15 psi or more between the inlet pressure and filter out gauge indicates that the pre-filter requires replacement.

EXAMPLE

If the inlet pressure is 60 psi, the filter should be changed when the filter out pressure is 50 psi or below.



## COMPONENT DESCRIPTIONS

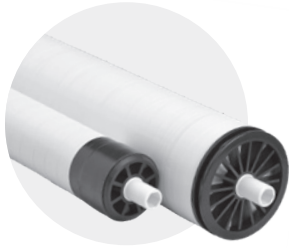

### **XE3–Series RO Membranes**

The reverse osmosis system is equipped with AXEON XE3–Series RO membranes. These membranes separate impurities from water through the reverse osmosis process.

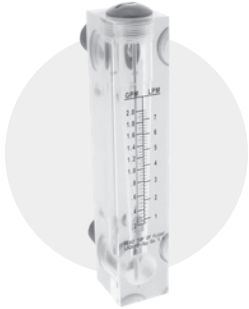

### **Permeate Flow Meter**

A clear acrylic analog flow meter is provided to measure the amount of product water.



### **Low Pressure Switch**

The low pressure switch shuts off the system when the feed water pressure drops below 15 PSI, preventing damage to the pump. The system restarts automatically when there is a constant pressure of 35 PSI or more.



### **Pump Pressure Gauge**

The pump pressure gauge measures the pressure of the water as it exits the pump to enter the first membrane in the system.



### **Pump**

The NL-PRO Series features a multi-stage centrifugal stainless steel pump. If any damage occurs to your system's pump, contact your local dealer or distributor and inform them of your system and pump model.



Never run the pump dry. Operating the pump without sufficient feed flow will cause damage or failure.

## MEMBRANE INFORMATION

NL-PRO Series reverse osmosis systems come standard with XE3-Series Reverse Osmosis Membrane Elements. General membrane element performance characteristics are listed on the following membrane specification chart.

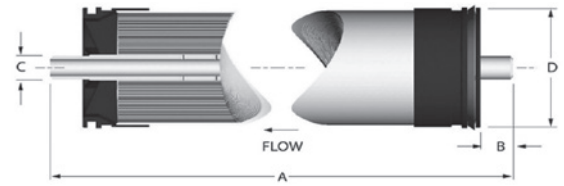

### XE3-SERIES MEMBRANES (STANDARD)—SPECIFICATIONS/OPERATING LIMITS

<b>Membrane Type</b>	Polyamide Thin-Film Composite
<b>Maximum Operating Temperature (°F / °C)<sup>A</sup></b>	113 / 45
<b>Maximum Operating Pressure (psi / bar)</b>	600 / 40.8
<b>pH Range (Continuous Operation)</b>	4-10
<b>pH Range (Short Term Cleaning—30 Min.)</b>	2-12
<b>Maximum Feed Silt Density Index (SDI)</b>	3
<b>Chlorine Tolerance</b>	0 ppm
<b>Maximum Feed Flow Rate</b>	14 gpm

A. Maximum temperature for continuous operations above pH 10 is 95 °F / 35 °C.

PRODUCT SPECIFICATIONS				DIMENSIONS (IN / MM)			
Part #	Description	Applied Pressure (psi / bar)	Permeate Flow Rate (gpd / lpd)	A	B	C	D
212285	XE3-4040	70 / 4.76	2,750 / 10,408	40 / 1016	1.04 / 26.5	0.75 / 19.1	3.9 / 99
		80 / 5.44	3,000 / 11,355				
		100 / 6.80	3,500 / 13,247				

**Warranty Evaluation Test Conditions:** Permeate flow and salt rejection based on the following test conditions: 550 ppm, filtered and dechlorinated municipal tap water, 77 °F / 25 °C, 15% recovery and the specified operating pressure. Minimum salt rejection is 96%. Permeate flows for warranty evaluation may vary +/-20%.

Proper start-up of reverse osmosis water treatment systems is essential to prepare the membranes for operating service and to prevent membrane damage due to overfeeding or hydraulic shock. Before initiating system start-up procedures, membrane pretreatment, loading of the membrane elements, instrument calibration and other system checks should be completed.

Avoid any abrupt pressure or cross-flow variations on the spiral elements during start-up, shutdown, cleaning or other sequences to prevent possible membrane damage. During start-up, a gradual change from a standstill to operating state is recommended as follows:

- Feed pressure should be increased gradually over a 30-60 second time frame.
- Cross-flow velocity at set operating point should be achieved gradually over 15-20 seconds.
- Permeate obtained from first hour of operation should be discarded.
- Maximum pressure drop across an entire single membrane pressure vessel (housing) can be up to 15 psi / 1.03 bar.
- Avoid static permeate-side backpressure at all times.

# MEMBRANE WARRANTY

Under certain conditions, the presence of free chlorine, chloramines and other oxidizing agents will cause premature membrane failure. Since oxidation damage is not covered under warranty, the manufacturer recommends removing all oxidizing agents by pretreatment prior to membrane exposure. Please contact the manufacturer or your supplier for more information.

Do not use this initial permeate for drinking water or food preparation. Keep elements moist at all times after initial wetting. To prevent biological growth during prolonged system shutdowns, it is recommended that membrane elements be immersed in a preservative solution. Rinse out the preservative before use. For membrane warranty details, please contact the manufacturer or your supplier for more information.

If operating limits and guidelines given in this product specification sheet are not strictly followed, the warranty will be null and void. The customer is fully responsible for the effects of incompatible chemicals and lubricants on elements. Use of any such chemicals or lubricants will void the warranty. These membranes may be subject to drinking water application restrictions in some countries: please check the application status before use and sale. The use of this product in and of itself does not necessarily guarantee the removal of cysts and pathogens from water. Effective cyst and pathogen reduction is dependent on the complete System design and on the operation and maintenance of the system.

No freedom from infringement of any patent owned by the manufacturer or others is to be inferred. Because use conditions and applicable laws may differ from one location to another and may change with time, customer is responsible for determining whether products and the information in this document are appropriate for customer's use and for ensuring that customer's workplace and disposal practices are in compliance with applicable laws and other governmental enactments. The claims made may not have been approved for use in all countries. The manufacturer assumes no obligation or liability for the information in this document. AXEON reserves the right to update this information periodically for the purposes of quality and accuracy.

**NO WARRANTIES ARE GIVEN; ALL IMPLIED WARRANTIES OF MERCHANTABILITY OR FITNESS FOR A PARTICULAR PURPOSE ARE EXPRESSLY EXCLUDED.**

## Membrane Performance Outside of Operating Limits

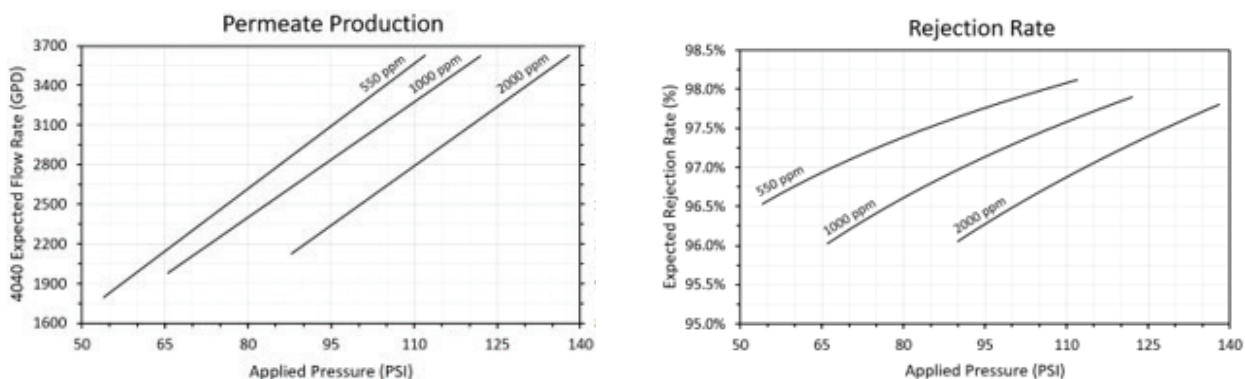

Information provided for operation outside of the specified operating limits is not intended to replace simulation projections for system performance based on specific feed water compositions. Membrane life span, production, and product water quality may be reduced when operating the membrane(s) outside of the conditions outline in the **Membrane Element Specifications and Operating Limits** section of this document. When operating outside of the specified operating limits system pre-treatment including but not limited to softening, chemical injection, and ultra-filtration are highly recommended. For a true indication of how a system will likely perform, a feed water analysis along with simulation projections are required. The data shown in the graphs was obtained through testing using filtered and dechlorinated municipal tap water at temperatures of 77 °F or lower. Performance will vary due to feed water temperature, TDS levels, and variations of the flat sheet. For more information on how this membrane will perform under certain conditions, please contact a LOCAL DEALER OR DISTRIBUTOR.

## MEMBRANE PERFORMANCE

NL-PRO Series Reverse Osmosis Systems are designed to produce 2,000-4,000 GPD at 77 °F (nominal) of permeate water per membrane at 98% rejection under the proper conditions. For example, the NL-PRO 2000 produces 2,000 gallons per day of permeate water at the listed operating test conditions.

### Rejection

The amount of total dissolved solids (TDS) rejected by the membrane is expressed as a percentage. NL-PRO Series reverse osmosis systems are designed to reject up to 98% NaCl depending on feed water chemistry. A 98% rejection rate means that 98% of total dissolved solids do not pass through the membrane. To calculate the percent of rejection, use the following formula:

FORMULA	$\frac{\text{Feed TDS} - \text{Permeate TDS}}{\text{Feed TDS}}$	x	100	=	% Rejection
EXAMPLE	$\frac{550 \text{ TDS} - 11 \text{ TDS}}{550 \text{ TDS}}$	x	100	=	98% Rejection

### Recovery

The amount of permeate water recovered for use is expressed as a percentage. To calculate percent of recovery, use the following formula (*note: the feed water flow rate is the product water flow rate + the concentrate water flow rate*):

FORMULA	$\frac{\text{Product Water Flow Rate}}{\text{Feed Water Flow Rate}}$	x	100	=	% Recovery
EXAMPLE	$\frac{1.39 \text{ GPM}}{4.39 \text{ GPM}}$	x	100	=	32% Recovery



All flow rates must be expressed in the same units, typically gallons per minute (gpm).

# SYSTEM INSTALLATION

## Mounting

When choosing a location to install the system, select an area with enough room to remove the membranes and easily access components and connections. Make sure there is enough room for service to be performed on the system. Take into consideration where your electrical power supply is located and where the nearest drain is located. Do not install system in direct sunlight or subject the system to temperature extremes and/or excess humidity. The NL-PRO Series system should be secured in compliance with state and local regulations.

## Feed Water Connection

Attach the water supply plumbing to the 3/4" FNPT elbow labeled "FEED".



NL-PRO systems must have a feed water line to the system no less than 3/4". Using smaller line sizes will cause pressure fluctuations and possibly affect the system performance.

## Permeate Water Connection

Locate the 1/2" quick connection on the outlet of the permeate flow meter labeled "PERMEATE", and run plumbing to a storage tank.



The pH of the reverse osmosis permeate water will typically be 1-2 points lower than the feed water pH. A low pH can be very aggressive to some plumbing materials such as copper piping.

## Concentrate Water (Waste) Connection

Locate the 1/2" quick connection on the outlet labeled "CONCENTRATE", and run plumbing to a drain. It is advised that an air-break be used on the concentrate line to prevent siphoning of water from the pressure vessels when the system is in standby.



Any restrictions or blockage in the drain line can cause backpressure, which will increase the system's operating pressure. This can result in damage to the system's membranes and components. Do not fully close the concentrate.

## Electrical

NL-PRO Series systems are available in 115 or 230V/60HZ/1PH. Each NL-PRO Series system is equipped with an 8 foot electrical cord to supply the system power. It is best that the NL-PRO Series system be wired to a dedicated electrical circuit. Ensure that the electrical circuit supplying the system is compatible with the requirements of the specific NL-PRO Series model you are installing.



To reduce the risk of electrical shock, the incoming power supply must include a protective earth ground.



It is recommended that a licensed electrician wire your system in accordance with local and national electrical codes (NEC).

# MEMBRANE INSTALLATION AND HANDLING



All pressure gauges must read zero before beginning this procedure. Turn the system off, disconnect the power, and bleed all water pressure from the system.



The brine seal must be in the correct position for each membrane housing in order for the membrane to function correctly.

Pay close attention to the flow direction arrows on the membrane housings when installing new membranes. Refer to the following images:

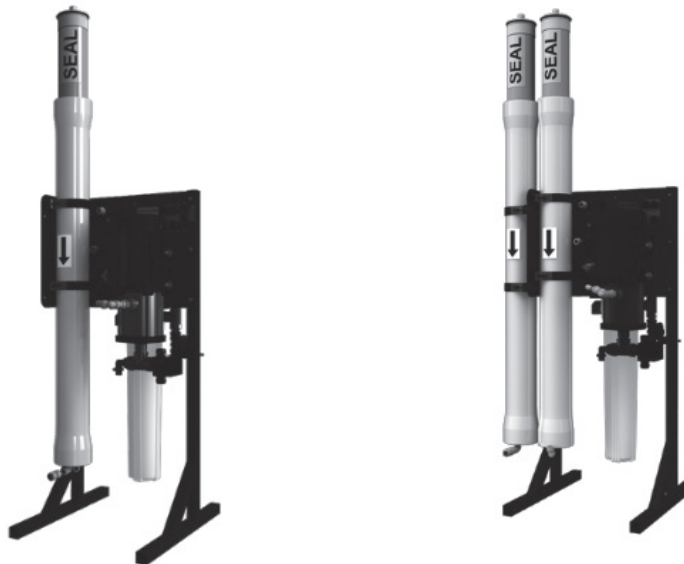

## Membrane Installation/Replacement



Wear gloves for the following steps in order not to contaminate the membrane.

1. Remove the permeate plumbing and/or fittings from the permeate port of the top end plug on the pressure vessel. Unscrew and remove the two locking crescents using a #5mm Hex wrench. Use a 1/2" x 6" PVC nipple (or similar material) and thread it into the end plug permeate port to hand tightness. Pull the pipe outward to remove the end plug. If the pressure vessel has been in operation for an extended time, a slight rocking motion or forceful tug may be required. Set the end plug aside in a clean area where the O-ring will not pick up dirt or debris.



## Membrane Installation/Replacement (Cont.)

2. Remove the membrane bag containing the membrane element from the shipping box.
3. Cut the bag open as close as possible to the seal at the end of the bag, so the bag may be re-used if necessary.
4. Make sure that all parts are clean and free from dirt. Examine the brine seal and permeate tube for nicks or cuts. Replace the O-rings or brine seal if damaged.
5. Remove the old membranes from the pressure vessels. Use long nose pliers to pull the old membrane out of the pressure vessel.
6. Lubricate the brine seal and O-rings on the new membranes with a non-petroleum based lubricant, such as Dow Corning® 111. Do not use a petroleum-based lubricant.
7. Apply the same lubricant to the inside of the pressure vessel below the groove of locking crescents, where the membrane brine seal will make contact when inserted.
8. Install membranes with brine seal location as depicted on page #.
9. The membrane should stop when fully seated on the bottom end plug.
10. Reassemble the top end plug(s).



Make sure the o-rings and end plugs are free from dirt and debris before reinstalling. Dirt and other foreign materials left on the end plugs can cause leaks and/or damage to the membranes and cause contamination.

11. Re-install the end plugs by gently and evenly pushing them onto the pressure vessel. Ensure that you do not pinch or fatigue any O-rings while re-installing the end plug. Push the end plug in until it is seated just below the groove for the locking crescents.
12. Reinstall the locking crescents and securely tighten the screws.
13. Reconnect any fittings that may have been disconnected when the pressure vessels were disassembled.
14. To start-up the system, please refer to the System Purging/Initial Start-Up section of this User's Manual.



The membranes must be flushed for at least 1 hour to remove the preservative from the membrane. Discard all of the permeate produced during the flush period.

## SYSTEM PURGING/INITIAL START-UP



Carefully inspect your system before initial start up. Check that all the plumbing and electrical connections are in place and securely fastened. Leave the power to the system off until step 8 of this procedure.



1. Redirect permeate water to the drain for this procedure.
2. Rotate lever located on the top of the solenoid valve (shown below).
3. Turn the feedwater on and let the system purge for about 5-10 minutes.
4. Close the lever on the top of the solenoid valve.
5. Turn the system on, position-2.
6. Allow the system to run uninterrupted for at least 1 hour to flush the preservative solution from the system and inspect the system for leaks.
7. After 1 hour, shut down the system.
8. Redirect the permeate water back to the tank and then turn the system back on.
9. Using the Reverse Osmosis System Operation Log provided on page #, record your system's readings daily for a week. After a week, record the readings at a minimum of once a week. It is suggested to make several copies of this sheet for future use before recording initial readings.

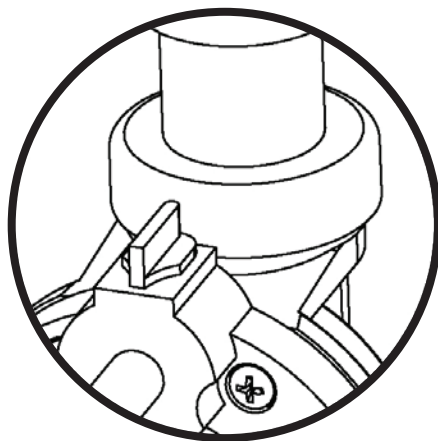

Lever Inline  
Operating Position

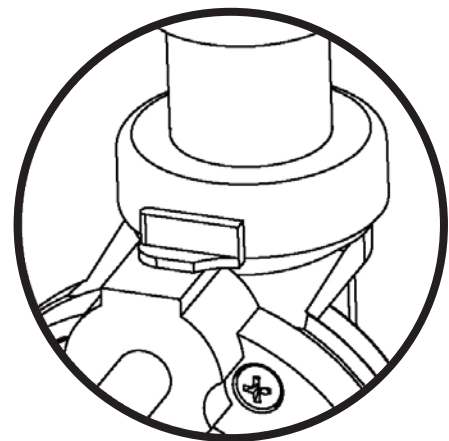



Lever Offset  
Bypass Position

# GENERAL MAINTENANCE AND STORAGE

## Preparing the Unit for Storage

If the system is to be shut down for an extended period, a membrane preservative should be used to preserve the membranes.

	<p>Prior to storing your system, the system should be cleaned with AXEON C-10 and C-20 cleaners, flushed with permeate water and M-100 solution for membranes to protect it from biological attack.</p>
	<p>The pressure vessels and plumbing lines of the system must be completely drained or filled with 10-40% propylene glycol mix (to prevent freezing). Any water remaining in the plumbing of a system may freeze, causing serious damage.</p>

1. Completely immerse the elements in the membrane housings using 2% M-100 solution<sup>A</sup>.
2. Separate the preservative solution from the air outside by closing all valves. Any contact with oxygen will oxidize the M-100 solution.
3. Check the pH once a week. When the pH becomes 3 or lower, change the preservation solution.
4. Repeat this process at least once a month.

A. For cold weather/winter storage add 10-40% by weight Propylene Glycol to the 2% M-100 solution. Add Propylene Glycol AFTER the 2% M-100 solution has been mixed. Refer to the chart below for the weight percent to be added.

### FREEZING POINT DEPRESSION OF PROPYLENE GLYCOL SOLUTION BY % WEIGHT

Freezing Point (°F)	26	18	7	-8
Propylene Glycol %	10	20	30	40

EXAMPLE

If the lowest temperature the system would experience in storage is 15 °F, it would be advisable to mix a 30% by weight solution of Propylene Glycol in your 2% M-100 preservative solution. The 30% solution will prevent freezing at temperatures down to 7 °F.

## TEMPERATURE CORRECTION FACTORS

A membrane's stated permeate production rate is based on a water temperature of 77 °F degrees Fahrenheit. Temperatures above or below 77 °F will increase or decrease the membrane's production rate.

Find the temperature correction factor (TCF) for your water temperature on the table located on the next page. Divide the rated permeate flow by the temperature correction factor. The result is the nominal permeate flow rate the system should achieve at actual water temperature. Permeate flow should be within 20% of the rated production, after correcting the feed water temperatures above or below 77 °F. Check your permeate flow meter to determine the permeate flow rate.

EXAMPLE

5 GPM at 59 °F

→

$$\frac{5 \text{ GPM}}{1.422}$$

=

3.52 GPM

EXAMPLE

5 GPM at 77 °F

→

$$\frac{5 \text{ GPM}}{1}$$

=

5 GPM

EXAMPLE

5 GPM at 84 °F

→

$$\frac{5 \text{ GPM}}{.892}$$

=

5.62 GPM



## TEMPERATURE CORRECTION TABLE

Temp °F (°C)	TCF	Temp °F (°C)	TCF	Temp °F (°C)	TCF	Temp °F (°C)	TCF	Temp °F (°C)	TCF
50.0 (10.0)	1.711	57.2 (14.0)	1.475	64.4 (18.0)	1.276	71.6 (22.0)	1.109	78.8 (26.0)	0.971
50.2 (10.1)	1.705	57.4 (14.1)	1.469	64.6 (18.1)	1.272	71.8 (22.1)	1.105	79.0 (26.1)	0.968
50.4 (10.2)	1.698	57.6 (14.2)	1.464	64.8 (18.2)	1.267	72.0 (22.2)	1.101	79.2 (26.2)	0.965
50.5 (10.3)	1.692	57.7 (14.3)	1.459	64.9 (18.3)	1.262	72.1 (22.3)	1.097	79.3 (26.3)	0.962
50.7 (10.4)	1.686	57.9 (14.4)	1.453	65.1 (18.4)	1.258	72.3 (22.4)	1.093	79.5 (26.4)	0.959
50.9 (10.5)	1.679	58.1 (14.5)	1.448	65.3 (18.5)	1.254	72.5 (22.5)	1.090	79.7 (26.5)	0.957
51.1 (10.6)	1.673	58.3 (14.6)	1.443	65.5 (18.6)	1.249	72.7 (22.6)	1.086	79.9 (26.6)	0.954
51.3 (10.7)	1.667	58.5 (14.7)	1.437	65.7 (18.7)	1.245	72.9 (22.7)	1.082	80.1 (26.7)	0.951
51.4 (10.8)	1.660	58.6 (14.8)	1.432	65.8 (18.8)	1.240	73.0 (22.8)	1.078	80.2 (26.8)	0.948
51.6 (10.9)	1.654	58.8 (14.9)	1.427	66.0 (18.9)	1.236	73.2 (22.9)	1.075	80.4 (26.9)	0.945
51.8 (11.0)	1.648	59.0 (15.0)	1.422	66.2 (19.0)	1.232	73.4 (23.0)	1.071	80.6 (27.0)	0.943
52.0 (11.1)	1.642	59.2 (15.1)	1.417	66.4 (19.1)	1.227	73.6 (23.1)	1.067	80.8 (27.1)	0.940
52.2 (11.2)	1.636	59.4 (15.2)	1.411	66.6 (19.2)	1.223	73.8 (23.2)	1.064	81.0 (27.2)	0.937
52.3 (11.3)	1.630	59.5 (15.3)	1.406	66.7 (19.3)	1.219	73.9 (23.3)	1.060	81.1 (27.3)	0.934
52.5 (11.4)	1.624	59.7 (15.4)	1.401	66.9 (19.4)	1.214	74.1 (23.4)	1.056	81.3 (27.4)	0.932
52.7 (11.5)	1.618	59.9 (15.5)	1.396	67.1 (19.5)	1.210	74.3 (23.5)	1.053	81.5 (27.5)	0.929
52.9 (11.6)	1.611	60.1 (15.6)	1.391	67.3 (19.6)	1.206	74.5 (23.6)	1.049	81.7 (27.6)	0.926
53.1 (11.7)	1.605	60.3 (15.7)	1.386	67.5 (19.7)	1.201	74.7 (23.7)	1.045	81.9 (27.7)	0.924
53.2 (11.8)	1.600	60.4 (15.8)	1.381	67.6 (19.8)	1.197	74.8 (23.8)	1.042	82.0 (27.8)	0.921
53.4 (11.9)	1.594	60.6 (15.9)	1.376	67.8 (19.9)	1.193	75.0 (23.9)	1.038	82.2 (27.9)	0.918
53.6 (12.0)	1.588	60.8 (16.0)	1.371	68.0 (20.0)	1.189	75.2 (24.0)	1.035	82.4 (28.0)	0.915
53.8 (12.1)	1.582	61.0 (16.1)	1.366	68.2 (20.1)	1.185	75.4 (24.1)	1.031	82.6 (28.1)	0.913
54.0 (12.2)	1.576	61.2 (16.2)	1.361	68.4 (20.2)	1.180	75.6 (24.2)	1.028	82.8 (28.2)	0.910
54.1 (12.3)	1.570	61.3 (16.3)	1.356	68.5 (20.3)	1.176	75.7 (24.3)	1.024	82.9 (28.3)	0.908
54.3 (12.4)	1.564	61.5 (16.4)	1.351	68.7 (20.4)	1.172	75.9 (24.4)	1.021	83.1 (28.4)	0.905
54.5 (12.5)	1.558	61.7 (16.5)	1.347	68.9 (20.5)	1.168	76.1 (24.5)	1.017	83.3 (28.5)	0.902
54.7 (12.6)	1.553	61.9 (16.6)	1.342	69.1 (20.6)	1.164	76.3 (24.6)	1.014	83.5 (28.6)	0.900
54.9 (12.7)	1.547	62.1 (16.7)	1.337	69.3 (20.7)	1.160	76.5 (24.7)	1.010	83.7 (28.7)	0.897
55.0 (12.8)	1.541	62.2 (16.8)	1.332	69.4 (20.8)	1.156	76.6 (24.8)	1.007	83.8 (28.8)	0.894
55.2 (12.9)	1.536	62.4 (16.9)	1.327	69.6 (20.9)	1.152	76.8 (24.9)	1.003	84.0 (28.9)	0.892
55.4 (13.0)	1.530	62.6 (17.0)	1.323	69.8 (21.0)	1.148	77.0 (25.0)	1.000	84.2 (29.0)	0.889
55.6 (13.1)	1.524	62.8 (17.1)	1.318	70.0 (21.1)	1.144	77.2 (25.1)	0.997	84.4 (29.1)	0.887
55.8 (13.2)	1.519	63.0 (17.2)	1.313	70.2 (21.2)	1.140	77.4 (25.2)	0.994	84.6 (29.2)	0.884
55.9 (13.3)	1.513	63.1 (17.3)	1.308	70.3 (21.3)	1.136	77.5 (25.3)	0.991	84.7 (29.3)	0.882
56.1 (13.4)	1.508	63.3 (17.4)	1.304	70.5 (21.4)	1.132	77.7 (25.4)	0.988	84.9 (29.4)	0.879
56.3 (13.5)	1.502	63.5 (17.5)	1.299	70.7 (21.5)	1.128	77.9 (25.5)	0.985	85.1 (29.5)	0.877
56.5 (13.6)	1.496	63.7 (17.6)	1.294	70.9 (21.6)	1.124	78.1 (25.6)	0.982	85.3 (29.6)	0.874
56.7 (13.7)	1.491	63.9 (17.7)	1.290	71.1 (21.7)	1.120	78.3 (25.7)	0.979	85.5 (29.7)	0.871
56.8 (13.8)	1.486	64.0 (17.8)	1.285	71.2 (21.8)	1.116	78.4 (25.8)	0.977	85.6 (29.8)	0.869
57.0 (13.9)	1.480	64.2 (17.9)	1.281	71.4 (21.9)	1.112	78.6 (25.9)	0.974	85.8 (29.9)	0.866

°F=(°C x 9/5) + 32

Corrected Flow Rate= (Measured Flow Rate) \* (TCF @ Feed Water Temp.)

# REVERSE OSMOSIS OPERATING LOG

Company Name \_\_\_\_\_

Day of Start Up \_\_\_\_\_

Location \_\_\_\_\_

Date of Last Cleaning \_\_\_\_\_

Week Of \_\_\_\_\_

System Serial No. \_\_\_\_\_

<b>Date</b>					
<b>Time</b>					
<b>Hour of Operation</b>					
<b>Filter Inlet Pressure (psi)</b>					
<b>Filter Outlet Pressure (psi)</b>					
<b>Pump Discharge Pressure (psi)</b>					
<b>Concentrate Pressure (psi)</b>					
<b>Feed Flow (gpm)</b>					
<b>Permeate Flow (gpm)</b>					
<b>Concentrate Flow (gpm)</b>					
<b>Recycle Flow (gpm)</b>					
<b>Recovery %</b>					
<b>Feed Temperature</b>					
<b>Feed TDS (ppm)</b>					
<b>Permeate TDS (ppm)</b>					
<b>Rejection %</b>					
<b>Feed pH</b>					
<b>Permeate pH</b>					
<b>Scale Inhibitor Feed (ppm)</b>					
<b>Iron (mg / L)</b>					
<b>Free Chlorine (mg / L)</b>					
<b>Hardness (gpg CaCO<sub>3</sub>)</b>					

# TROUBLESHOOTING

SYMPTOM	POSSIBLE CAUSES	CORRECTIVE ACTION
Low inlet pressure	Low supply pressure	→ Increase inlet pressure
	Cartridge filters plugged	→ Change filters
	Leaks	→ Fix any visible leaks
Low permeate flow	Low operating pressure	→ See low inlet pressure
	Cold feed water	→ See temperature correction sheet
	Defective membrane brine seal	→ Inspect and/or replace brine seal
	Fouled or scaled membrane	→ Clean membranes with AXEON C-10 and C-20 membrane cleaners
High permeate flow	Exceeding maximum feed water temperature	→ See temperature correction sheet
	Damaged or oxidized membrane	→ Replace membrane
	Damage product tube O-rings	→ Inspect and/or replace
Poor permeate quality	Damaged or oxidized membrane	→ Replace membrane
	Metal oxide fouling	→ Improve pretreatment to remove metals; clean with acid cleaners
	Colloidal fouling	→ Optimize pretreatment for colloid removal; clean with high pH anionic cleaners
	Low operating pressure	→ See low inlet pressure
Membrane fouling	Scaling ( $\text{CaSO}_4$ , $\text{CaSO}_3$ , $\text{BaSO}_4$ , $\text{SiO}_2$ )	→ Increase acid addition and antiscalant dosage for $\text{CaCO}_3$ and $\text{CaSO}_4$ ; reduce recovery; clean with acid cleaners
	Biological fouling	→ Shock dosage of sodium bi-sulfate; continuous feed of sodium bi-sulfate at reduced pH; chlorination and de-chlorination; replace cartridge filters
	Organic fouling	→ Activated carbon or other pretreatment; clean with high pH cleaner, AXEON C-20.
	Chlorine oxidation	→ Check chlorine feed equipment and de-chlorination system
	Abrasion of membrane by crystalline material	→ Improve pretreatment; check all filters for media leakage

**If technical assistance is required, contact your local dealer or distributor. Prior to making the call, have the following information available: system installation date, serial number, and a detailed description of the problem.**



# NL-PRO 4000 FLOW DIAGRAM

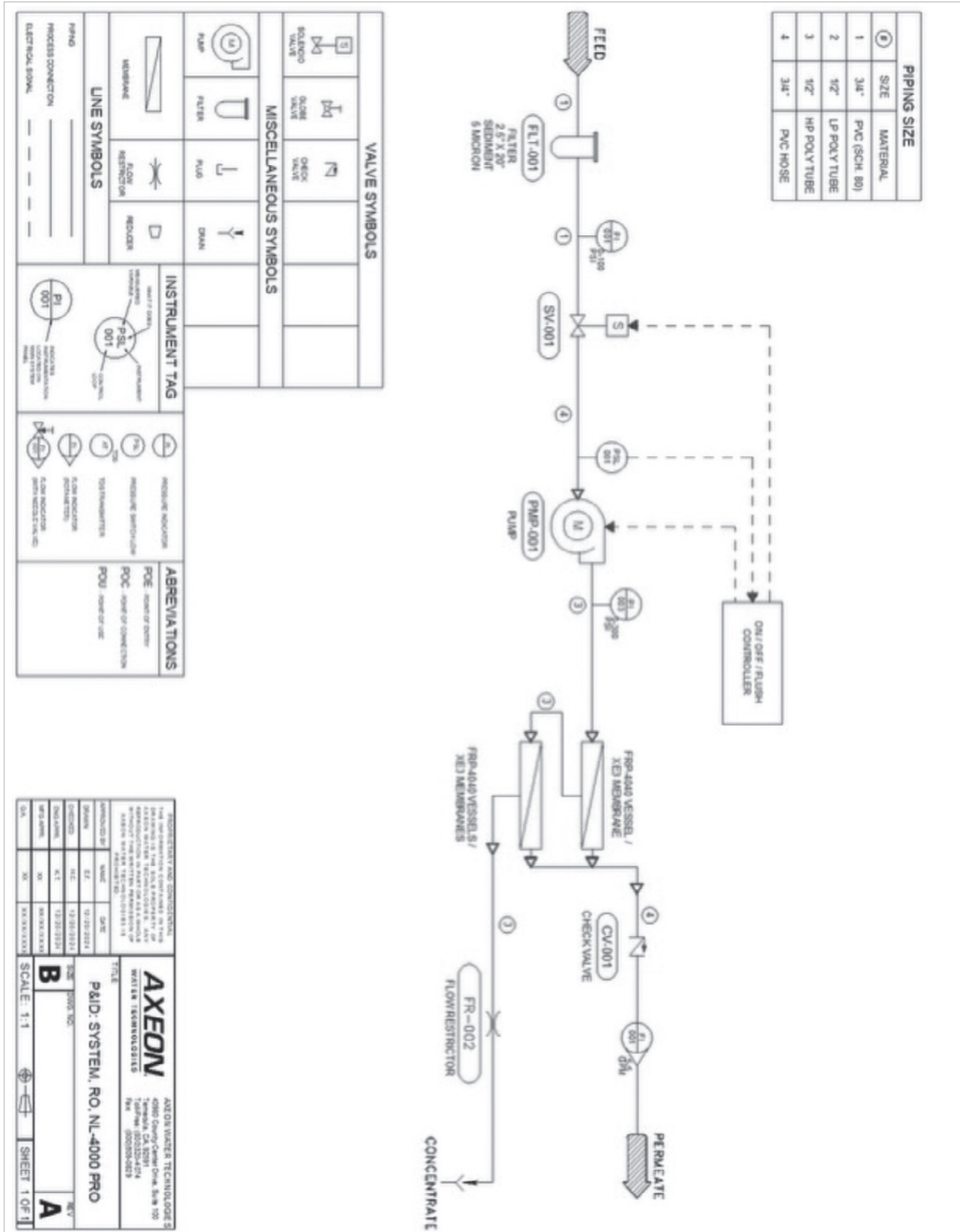

VALVE SYMBOLS	
	SOLENOID VALVE
	GLOBE VALVE
	CHECK VALVE

MISCELLANEOUS SYMBOLS	
	PUMP
	FILTER
	FLOW RESTRICTOR
	MEMBRANE

INSTRUMENT TAG	
	PM-001 PRESSURE MONITOR 50 PSI 2500 GPM
	SV-001 SERVICE VALVE
	PMP-001 MEMBRANE PUMP

ABBREVIATIONS	
	RO - RO MEMBRANE
	XED - XED MEMBRANE
	FR - FLOW RESTRICTOR
	CV - CHECK VALVE
	SV - SOLENOID VALVE
	PMP - MEMBRANE PUMP
	PM - PRESSURE MONITOR
	SV - SERVICE VALVE
	M - MEMBRANE
	FR - FLOW RESTRICTOR
	CV - CHECK VALVE
	SV - SOLENOID VALVE
	PMP - MEMBRANE PUMP
	PM - PRESSURE MONITOR
	SV - SERVICE VALVE

REQUESTED AND CONFIRMED DRAWING TO THE SOLID STATE OF AXEON WATER TECHNOLOGIES, ANY CHANGES TO THIS DRAWING WITHOUT THE WRITTEN PERMISSION OF AXEON WATER TECHNOLOGIES IS PROHIBITED.	
DRAWN BY: [Name] CHECKED BY: [Name] DATE: 12/28/2014	DATE: 12/28/2014
TITLE: <b>AXEON</b> P&ID: SYSTEM, RO, NL-4000 PRO	
SCALE: 1:1	
SHEET 1 OF 1	

# NL-PRO 2000-4000 110V ELECTRICAL DIAGRAM

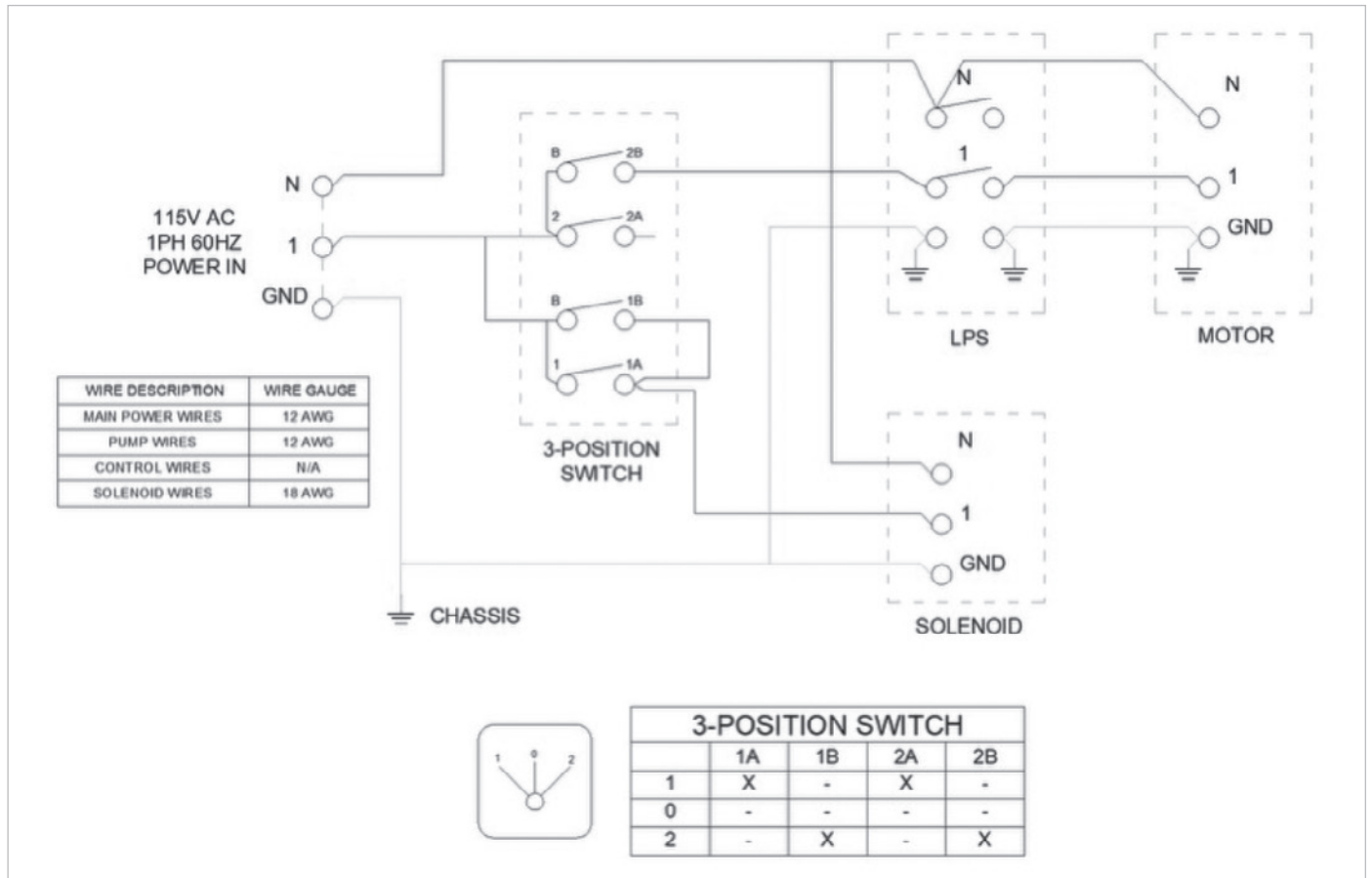

# NL-PRO 2000-4000 220V ELECTRICAL DIAGRAM

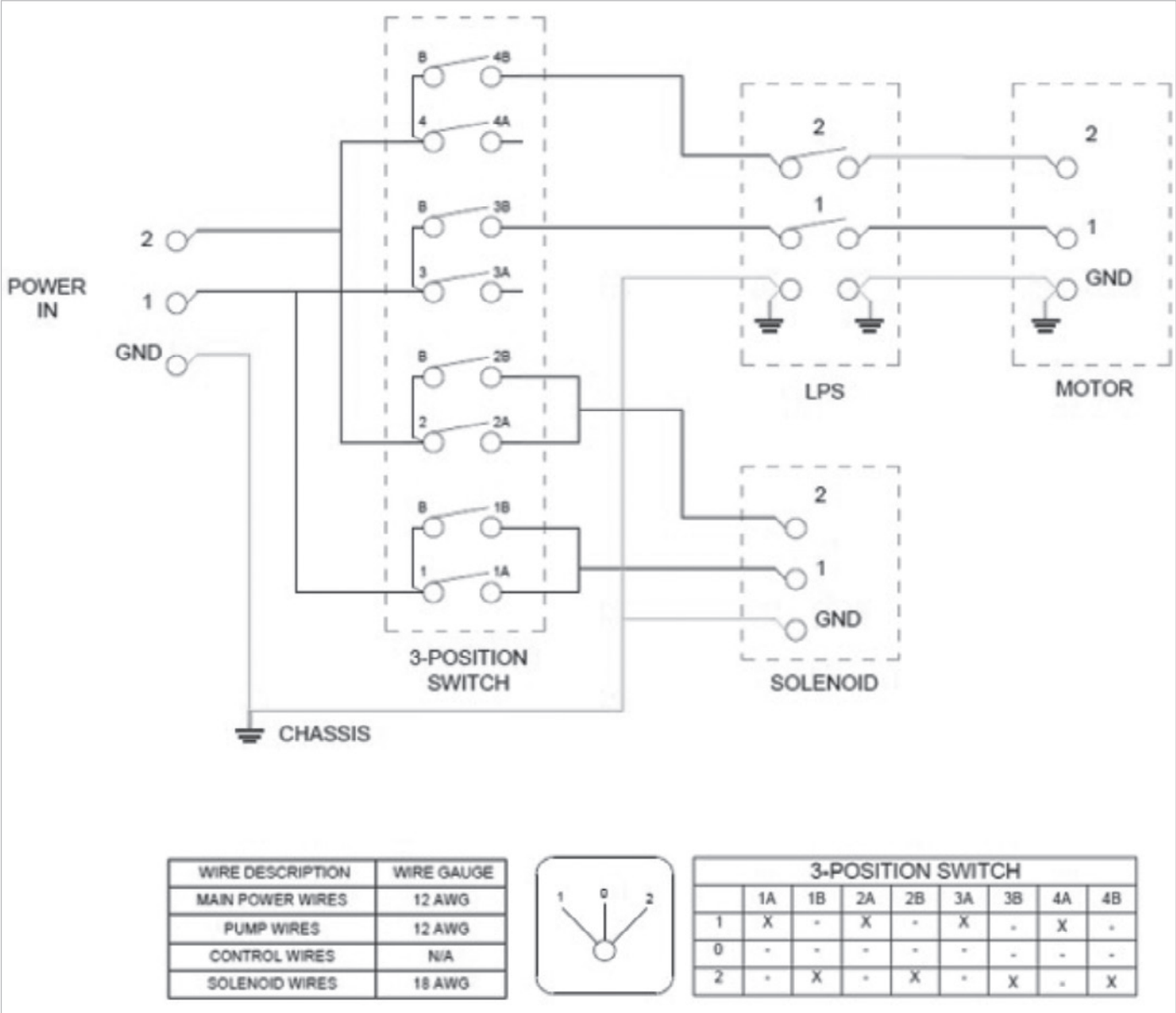

# SYSTEM WARRANTY

## Warranty Terms

Subject to the terms and conditions set forth hereinafter, the manufacturer (hereafter "Manufacturer") warrants to the original purchaser (hereafter the "Customer") that the systems and products manufactured by the Manufacturer are free from defects in material and in workmanship for twelve (12) months from the Warranty Commencement Date (as defined below) only when used strictly in accordance with the applicable operating instructions and within the range of the operating conditions specified by the Manufacturer for each such product.

This Warranty does not extend to systems, equipment, or components manufactured by others, nor to systems, equipment, or components manufactured by others and distributed by the Manufacturer. This Warranty does not extend to equipment or components manufactured by others which have been incorporated into a Manufacturer product but, if allowable the, Manufacturer hereby assigns, without warranty, to the Customer its interest, if any, under any Warranty made by the Manufacturer of such equipment or component. This Warranty does not cover disposable items such as fuses, O-rings, regeneration materials/chemicals, or other such disposable items, which must be replaced periodically under the normal and foreseeable operating conditions of the goods warranted hereby.

## Warranty Commencement Date

The Warranty Commencement Date for each Manufacturer product shall be the later of the date of: (1) receipt by the Customer, or (2) the date of installation at the Customer's premises provided that such installation must occur within three (3) months of shipment from the Manufacturer's manufacturing facility. In no event shall the Warranty Commencement Date exceed three (3) months from the shipment from the Manufacturer's manufacturing facility. The Customer shall provide proof of purchase in order to exercise rights granted under this Warranty. If requested by the Manufacturer, the Customer must also provide proof of the installation date.

## Warranty Service

THE MANUFACTURER'S OBLIGATION UNDER THIS WARRANTY IS LIMITED TO THE REPAIR OR REPLACEMENT (AT MANUFACTURER'S SOLE DISCRETION) OF ANY PRODUCT, OR COMPONENT THEREOF, PROVED TO BE DEFECTIVE IN MATERIAL OR WORKMANSHIP WITHIN THE COVERED WARRANTY PERIOD.

The Customer, at the Customer's risk and expense, shall be responsible for returning such product or component, only after obtaining a Return Goods Authorization (RGA) number from the Manufacturer, arranging for freight prepaid, and in conformance with any special packaging and shipping instructions set forth on the operation documentation or RGA instructions, or as otherwise reasonably required, to the Manufacturer, together with (1) RGA number issued by the Manufacturer at Customer's request; (2) proof of purchase and, if necessary, proof of installation date; (3) a Return Goods Authorization Form; (4) a description of the suspected defects; (5) the serial number of the Manufacturer product alleged to be defective; (6) a description of the type of water and pretreatment equipment which has been utilized in connection with the product, if any. The Manufacturer shall, in the Manufacturer's reasonable discretion, be the sole judge of whether a returned product or component is defective in material or workmanship. Required or replaced products or components shall be returned surface freight.

In genuine emergency situations, the Manufacturer will (at the Manufacturer's sole discretion) forward replacement parts to the Customer without waiting for authorized return of the questionable part(s). In such cases, Customer will issue a purchase order or other payment guarantee prior to shipment. If the returned part is found to have been misused or abused, or the defective part is not received by the Manufacturer within thirty (30) days; the Customer will be invoiced for the replacement part(s) provided. This Warranty does not cover or include labor and/or travel to the Customer's premise or location or any other location. Charges of \$2500 per day plus associated travel expenses will be incurred by the Customer in providing the Warranty Service at any location other than the Manufacturer's main headquarters; that is if the Manufacturer deems that the product is not covered by said Warranty. The Manufacturer reserves the right to precondition such travel to Customer's premises upon prepayment of the Manufacturer's anticipated costs of attending such premises.

## Voidability of Warranty

This Warranty shall be void and unenforceable as to any Manufacturer product which has been damaged by accident, mishandling, abuse or has been repaired, modified, altered, disassembled or otherwise tampered with by anyone other than the Manufacturer or an authorized Manufacturer service representative; or, if any replacement parts are not authorized by the Manufacturer have been used, or, the product has not been installed, operated and maintained in strict accordance and adherence with the operating documentation and manuals for such product. Any expressed Warranty, or similar representation of performance set forth in the operation documentation for media or resin incorporated into the Manufacturer product shall be void and unenforceable unless the feed water requirements set forth in the operating documentation for such product are unequivocally and strictly adhered to.

## Limitations and Exclusions

THIS WARRANTY AND REMEDIES DESCRIBED HEREIN AND HEREIN ABOVE ARE EXCLUSIVE AND IN LIEU OF ANY AND ALL OTHER WARRANTY OR REMEDIES, EXPRESSED OR IMPLIED, INCLUDING WITHOUT LIMITATION, ANY IMPLIED WARRANTY OF MERCHANTABILITY OR FITNESS FOR A PARTICULAR PURPOSE. IN NO EVENT SHALL THE MANUFACTURER BE LIABLE FOR ANY CONSEQUENTIAL, INCIDENTAL OR OTHER SIMILAR TYPES OF DAMAGES, DAMAGES FOR THE LOSS OF PRODUCTION OR PROFITS, OR INJURY TO PERSON OR PROPERTY. NO PERSON HAS ANY AUTHORITY TO BIND THE MANUFACTURER TO OTHER THAN WHAT IS SET FORTH ABOVE.

THIS WARRANTY GIVES THE CUSTOMER SPECIFIC LEGAL RIGHTS AND THE CUSTOMER MAY ALSO HAVE OTHER RIGHTS WHICH VARY FROM JURISDICTION TO JURISDICTION. THE PARTIES RECOGNIZE AND AGREE, THAT IN ALL RESPECTS THE LAWS OF THE STATE OF CALIFORNIA SHALL APPLY TO AND SHALL GOVERN ANY INTERPRETATION OR LEGAL SIGNIFICANCE OF THIS DOCUMENT.

NO WARRANTY OR OTHER LIABILITY OF THE MANUFACTURER TO CUSTOMER UNDER THIS AGREEMENT OR OTHERWISE WILL IN ANY EVENT EXCEED THE COST OF REPLACEMENT OF THE APPLICABLE MANUFACTURER PRODUCT, PART, OR ACCESSORY THAT IS SUBJECT TO ANY BREACH OF THE MANUFACTURER'S WARRANTY. THE MANUFACTURER WILL NOT BE LIABLE FOR ANY DAMAGE TO ANY PROPERTY OF CUSTOMER OR TO CUSTOMER'S CUSTOMERS FOR ANY CONSEQUENTIAL, INCIDENTAL, OR ECONOMIC LOSS OR COMMERCIAL DAMAGE WHATSOEVER. REMEDIES HEREIN PROVIDED ARE EXPRESSLY MADE THE SOLE AND EXCLUSIVE REMEDIES FOR BREACH OF ANY WARRANTY OR OTHER OBLIGATION HEREUNDER EXPRESS OR IMPLIED OR FROM THE OPERATION OF LAW.

**For more information, visit  
us at [AXEONWater.com](http://AXEONWater.com) or  
call 800-320-4074**





Unbeatable performance backed by more than three decades of AXEON's experience in the water filtration industry. Look for our Watermark of Distinction. **Call (800) 320-4074 or visit us at [AXEONwater.com](http://AXEONwater.com) to learn more.**