



# CHEF'SCOMBI 102G

Gas 10 Level - Full Size Steam Generator Combi



## SPECIFIER STATEMENT

Chef'sCombi 102G 10-level all-in-one multifunctional cooking equipment: convection, steam cooking, roasting, grilling, baking, air frying, poaching, simmering, low temperature cooking, defrosting, regeneration, holding. Advanced cooking technologies for premium cooking results with powerful heating elements, humidity sensor-controlled climate regulation, high-performance dehumidification, controlled even heat distribution and humidifying function.

### Exterior Dimensions:

Combi: 42.36"H x 41.02"W x 41.06"D

### Capacity:

(20) 12" x 20" hotel pans or  
(10) 18"x 26" full sheet pans

Project \_\_\_\_\_  
AIA # \_\_\_\_\_ SIS # \_\_\_\_\_  
Item # \_\_\_\_\_ Quantity \_\_\_\_\_ C.S.I. Section 114000

## MODELS

**CHEF-102G** (VICS102G-81) 10 Level - Full Size

*Note: Left Hinged Door (L) & Auto Grease Removal (GR) models are also available.*

## STANDARD FEATURES

- **CombiOS** is an innovative and intuitive operating concept, with a high-performance processor. The dial control and screen response time is fast, even when switching the oven on or off. The user interface can be easily customized to show or hide features, allowing users to focus on what is important to them.
- **CombiClimateControl** is the basis for outstanding cooking performance. The heat is distributed evenly, based on the demand — ensuring the best cooking results even when fully loaded. Fresh steam is supplied by the steam generator. The high-performance dehumidification secures the desired crispiness.
- **AutoClimate** supports the user during manual cooking. It sets the appropriate cooking climate based on the cabinet temperature set by the user, if desired.
- **CombiGuide** is the simple cooking assistant for reproducible cooking results, no matter who is using the oven. The user inputs desired result, and CombiGuide automatically sets the ideal cooking climate. The load detection will make the appropriate adjustments in the cooking climate, but the user can make adjustments at any time, if necessary.
- **MenuMix** monitors every level to the second. Various foods can be selected to be cooked together, and time can be set as countdown timers, or, as synchronized timers to finish products simultaneously at a specified time (example: multiple food items can be programmed to finish at exactly 11am; MenuMix will alert users when to load the food, and ensures it is cooked and ready by 11am). Mixed menus can be created and saved for future use.
- **CombiCare** is an automatic cleaning system with default and customizable cleaning programs that can be selected based on the cleaning impact needed, and uses proprietary solid cleaner tabs (to clean the cavity) and easy-to-use care sticks (for descaling). After a cleaning cycle has been completed, the cooking chamber, steam generator, and drain are hygienically clean and free of limescale.
- Two-year limited parts and labor warranty.

CHEF'SCOMBI 102G – Gas 10 Level - Full Size Steam Generator Combi

Approved by \_\_\_\_\_ Date \_\_\_\_\_ Approved by \_\_\_\_\_ Date \_\_\_\_\_

## OPERATION

- Capacitive 10" HD Touchscreen usable with gloves.
- Easy smartphone-like operation such as dragging, swiping, widgets, tutorials, etc.
- High-performance processor for responsive operation.
- Customization of the user interface to show or hide features for individual cooking preferences, with different languages.
- Creation of individual user profiles with optional PIN-codes.
- Easy-to-read screen content due to structured and large display of essential information.
- Loading and removal requests due to an energy-saving LED system, color display, and illuminated control button.
- Device status displayed via the illuminated control button visible from a distance.
- Clear indications of oven's operation status, such as: preheating, loading, unloading, and dynamic animations.
- Audible prompts and visual messages when user action is required.
- Extensive search function including all cooking paths, application examples and settings. Ability to apply filters and sort the search.
- Quick access to help and settings.
- Contextual help always shows current help content for the displayed screen content.
- Start the help file to check application example.
- Fast setting of desired temperature due to quick temperature selection menu.
- Fast adding of additional cooking time due to quick time selection menu.
- Top 12 favorites to ensure quick access to frequently used cooking methods.
- Time can be set to display in 12- or 24-hour format.
- Digital temperature display can be set to °C or °F, displays target and actual values.
- Humidity and time of cooking are digitally displayed; displays both target and actual values.
- Time setting is displayed in seconds, minutes, and hours.
- Sleep mode and an intermediate sleep mode for extended cycles, such as overnight cooking.

## AUTOMATIC COOKING FUNCTIONS

- Even energy distribution in the cooking cabinet is achieved by a controlled air distribution system with reversing fan wheel.
- Cooks with automatic control and adapts the cooking parameters to ensure optimum cooking results, regardless of product size or load.
- Automatic adaption of the cooking climate depending on the cooking temperature set.
- Setting the desired cooking result by determining the browning level, degree of cooking and product size.
- Load detection and adaption of the cooking parameters to ensure reproducible cooking quality independent from load quantity.
- Monitors and calculates the browning level based on the Maillard reaction.
- Controlled multi-level cooking with a timer for each level.
- Display of dishes that can be cooked together.
- Planning and recipe storage of mixed loads to ensure a standardized production process with consistent and reliable results.
- Core temperature positioning detection with user notification in case of incorrect positioning.
- Core temperature assistant for selecting the correct core temperature depending on the food to be cooked.
- Automatic proofing of baked goods.
- Intuitive and individual programming of an unlimited number of cooking recipes with an unlimited number of drag-and-drop steps.
- Easily transfer cooking recipes to other cooking systems via secure cloud connection or via USB.
- Degraded mode will provide a continuous convection cooking screen, whatever the breakdown (except system electrical failure), a malfunction button, etc., to complete the cooking cycle.
- Adaptive Speed Fan: Features 4 standard levels of fan speed, one maximum level, and automatically reduces the speed by half after 2 hours, while maintaining optimum performance.

As continued product improvement is a policy of Vulcan, specifications are subject to change without notice.

## COOKING FUNCTIONS

- Three cooking modes:
  - Convection:** hot air from 80-575°F
  - Steam:** from 90-270°F (hot steam from 213-270°F)
  - Combination of hot air and steam:** from 80-575°F
- Maximum cooking temperature 575°F.
- Powerful heating elements for brief heat-up times and fast compensation of the temperature drop during full loads or à la carte operation.
- Highly effective steam generator to provide maximum steam saturation with hygienic fresh steam even below 212°F.
- High power steam for special steam applications such as dumplings.
- Humidifying function for outstanding baking results, fluffy crumb toppings, and shiny crust.
- Percentage-accurate humidity setting and control from 0-100%.
- Percentage-accurate measurement of the humidity below 212°F for low temperature cooking.
- High performance dehumidification to ensure best possible evenness and crispness, even with large food quantities.
- Degree-accurate control of cooking cabinet temperature.
- Five adjustable air speeds.
- Fast cooling of the cabinet by air or water with door closed.
- Core temperature probe with three measuring points.
- Optional external (USB) core temperature probe with six measuring points for soft or very small cooking products.
- Delta-T mode cooking mode.
- Automatically pre-selected start time with changeable date and time.

## CLEANING AND CARE

- Automatic cleaning and care system of the cooking cabinet and steam generator, independent of water pressure.
- The cleaning process consists of four efficient wash cycles and one rinse cycle, reducing resource consumption while ensuring optimal cleaning.
- Automatic cleaning and removal of limescale deposits within the steam generator during the cleaning cycle.
- Multiple programs to target the specific level of desired cleanliness.
- Ultrafast rinsing in only six minutes for practically uninterrupted, hygienic production.
- Usage of solid cleaning tablets and care sticks to ensure easy operation.
- Advanced limescale management includes regular steam generator flushing and real-time detection of limescale level, ensuring optimal operation.
- Inside and outside material: stainless steel ASTM 304, seamless hygienic cooking cabinet with rounded corners to optimize air flow.
- Glass and stainless steel surfaces allow easy external cleaning.
- IPX5-class protection against spraying water in all directions.

## OCCUPATIONAL AND OPERATING EASE

- Maximum level height not higher than 63" when using an appropriate stand.
- Long-lasting and energy-efficient LEDs illuminate the cooking chamber, providing excellent color fidelity.
- Double-glazed cooking chamber door with rear ventilation, special heat-reflective coating, and rotating panels for easy cleaning. Contact temperature of the cooking cabinet door meets UL requirements.
- Integrated retractable sprayer for handheld spraying needs.
- Electronic over temperature limiter for steam generator and convection heating.
- Integrated fan wheel brake.
- HACCP data storage and output via USB or SmartConnect app.
- Tested according to appropriate standards for unsupervised operation (overnight cooking).
- Ergonomic door handle with right or left-handed door opening and swing-shut function.

As continued product improvement is a policy of Vulcan, specifications are subject to change without notice.

## NETWORKING

- Connectivity via Ethernet for a stable and secure connection. Ethernet interface.
- Integrated USB interface for local data exchange.
- Free SmartConnect app monitors in real time: energy and water usage, cleaning cycles, recipe history log (keeps track of programs used), HACCP temperature data (with and without core probe for food safety documentation), and error and warning messages — all conveniently via remote control.

## INSTALLATION, MAINTENANCE AND ENVIRONMENT

- Professional installation by authorized service agency technicians recommended.
- Adaptation to the installation site (height above sea level) through calibration at installation.
- Service diagnostic system with automatic service message display, self-test function for active testing of oven functions.
- Simplified accessibility allows easy maintenance interventions due to the standardization of component placement (components in all Chef'sCombi oven models are identically arranged).
- Electronic control board is directly accessible to service technicians, simplifying interventions and updates using maintenance mode.

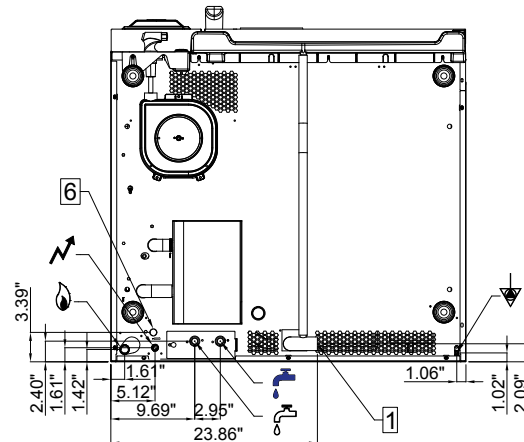
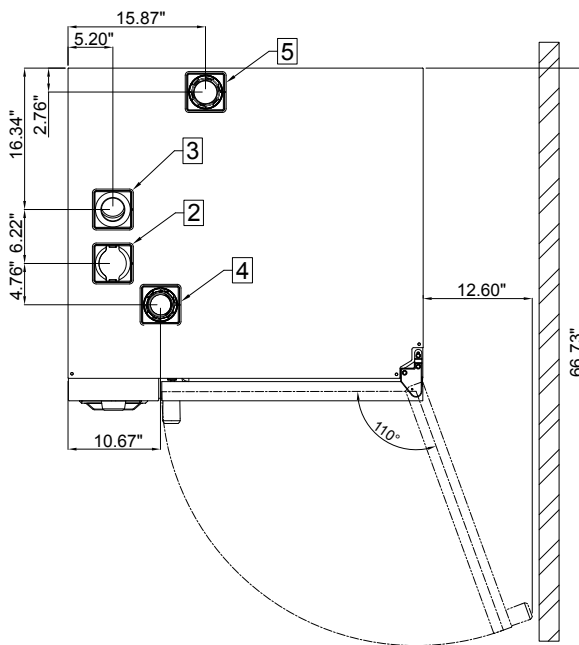
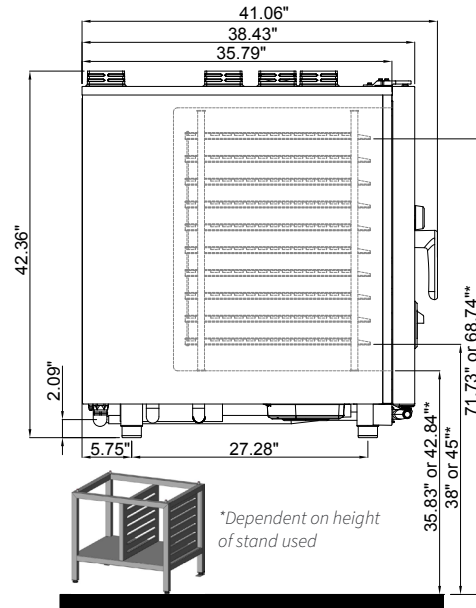
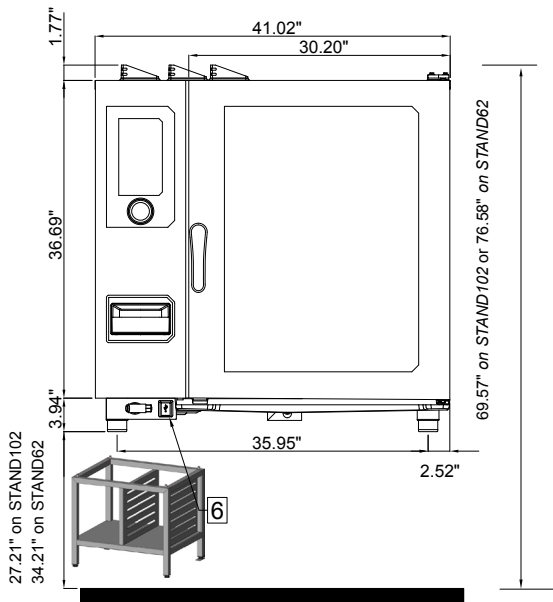

### Gas Connection

 Gas inlet at 3.35" from the support / 30.6" - 37.6\* from the floor  
\*Dependent on height of stand used

### Electrical Connection

 Electric inlet at 10.24" from the support  
37.4" - 44.5\* from the floor (allow a cable with 5' of slack)

### Water Connections

Unit ships with single or dual water connection capability.

 **Cold Potable Water**  
Water inlet at 3.15" from the support  
30.4" - 37.4\* from the floor

 **Cold Potable Soft Water**  
Water inlet at 3.15" from the support  
30.4" - 37.4\* from the floor

- 1 Drain**  
Drain outlet at 2.09" from the support  
29.3" - 36.3"\* from the floor
- 2 Vent Inlet**  
Stainless steel tube diameter 2.75"
- 3 Vent Outlet**  
Stainless steel tube diameter 1.75"
- 4 Cavity Combustion Flue**  
Stainless steel tube diameter 2.75"
- 5 Steam Generator Combustion Flue**  
Stainless steel tube diameter 2.36"
- 6 Ethernet Port**

As continued product improvement is a policy of Vulcan, specifications are subject to change without notice.

## DIMENSIONS (HEIGHT X WIDTH X DEPTH)

Exterior (total)	42.36"H x 41.02"W x 41.06"D
Maximum working height	68.74" on STAND62 61.73" on STAND102
Minimum working height	45" on STAND62 38" on STAND102
Oven height on stand	76.58" on STAND62 69.57" on STAND102
Packaged	50"H x 42.91"W x 42.91"D

## WEIGHT

596 lbs. gross / 541 lbs. net

## MINIMUM DISTANCES / WALLS

	LEFT	BACK	RIGHT
Recommend (technical access)	20"	0"	2"
Minimum spacing	2"	0"	2"
Heat sources	14"	0"	2"

*External heat sources from other equipment may require space or heat shield.*

## CAPACITIES

Number of seats per day	300
Levels	10 full
Hotel Pans	(20) 12" x 20"
Sheet Pans (full)	(10) 18" x 26"
Max depth of pans	2.56"
Spacing between floors	2.64"
Maximum load per level	22 lbs
Total maximum load	220.46 lbs

## AIR EXHAUST AND THERMAL LOAD

Latent thermal load	7416 W
Sensible heat emission	6180 W
Acoustic emission	<70 dB (A)

## CONNECTION SPECIFICS DATA

LAN data interface	RJ45
WiFi data interface	IEEE 802.11 ac/a/b/g/n

## WATER QUALITY STATEMENT

The fact that a water supply is potable is no guarantee that it is suitable for steam generation. All steam equipment is subject to contamination and failure due to chemical and mineral content found in water. A suitable Water Treatment System and regular filter replacements coupled with routine deliming is the recommended minimum. Damage as a result of poor water quality or lack of required owner/operator maintenance is the responsibility of the owner/operator.

Your water supply must be within these general guidelines:

<b>DYNAMIC WATER PRESSURE</b>	15-87 psig (30-60 recommended)
<b>HARDNESS*</b>	3.5-11.6 grains
<b>SILICA</b>	less than 13 ppm
<b>TOTAL CHLORIDE</b>	less than 150 ppm
<b>pH RANGE</b>	7-8
<b>CHLORINE &amp; CHLORAMINE</b>	0 ppm
<b>ALKALINITY</b>	less than 20 ppm
<b>TDS</b>	less than 60 ppm
<b>UN-DISSOLVED SOLIDS</b>	less than 5 microns

\* 17.1 ppm = 1 grain of hardness

Other factors affecting steam generation are iron content, amount of chlorination and dissolved gases. Water supplies vary from state to state and from locations within a state. Therefore it is necessary that the local water treatment specialist be consulted before the installation of any steam generating equipment.

## USER RESPONSIBILITY

The oven must be installed, operated, cleaned, and maintained as described in the Manual furnished with the oven. It is the responsibility of the owner and installer to comply with local codes.

## SERVICE CONNECTIONS

**Water:** Oven ships with single or dual water connection capability. ¾" GHT-M (male garden hose) connection(s) on the oven.

Note: Water is a customer supplied utility that must meet the water specs of the oven.

**Drain:** 1 ½" diameter.

**Electrical:** 120/60/1 - Power 0.6 kW / 5.8 Amp with 6' cord and plug NEMA L5-15.

Note: Field convertible to 208/240V 1NAC (cord and plug has to be changed on site with NEMA 6-15P).

### Gas:

**Natural** - 143,310 BTU/hr  
¾" NPT male connection on oven  
Supply pressure - 6.5" - 10" W.C.

**Propane** - 136,144 BTU/hr  
10" - 15" W.C.

Ships as natural gas with field conversion kit included.

## ACCESSORIES

### COOKING

- VRACK-102** Stainless steel grab-and-go racks (5)
- PERFTRAY1.1** Perforated baking tray 12"x20"
- PERFTRAY2.1** Perforated baking tray 20"x24"
- CHEF-GPAN1** Grease pan kit
- EGGTRAY** Eggs tray 8 holes
- ENAMEL40** Tray granite enameled depth 40mm
- ENAMEL60** Tray granite enameled depth 60mm
- PIZZATRAY** Pizza and baking tray
- GRILL-PIZZATRAY** Cross grill & pizza DURQUARZ coated reversible
- DIAMONDGRILL** Baking and grill tray diamond shape
- ROAST-BAKETRAY** Roasting and baking tray
- CHICKRACK6** Stainless steel chicken rack - 6
- CHICKRACK8** Stainless steel chicken rack - 8
- RIBRACK** Ribs rack
- 1220-GRILLOP** Grilling Grid (open type)
- 1220-BASKET** Stainless steel fry basket 12"x20"
- FRYBASKET** Frying baskets coated with DURAPEK

### STACKING KITS

- CHEF-STACK2G** Stacking kit

*Note: One of the following three choices is required with stacking kit:*

- CHEF-6NLEG2** Stand 6" (150mm) for stacked ovens (recommended)
- CHEF-10NLEG2** Stand 10" (250mm) for stacked ovens (for longer drain connections and 6/6 stacked units)
- CHEF-6NCAST2** Mobile stand 6" (150mm) for stacked ovens (level floor recommended)

### STAND & CASTERS

- CHEF-STAND102** Stainless steel stand with shelving
- CHEF-CAST2** Stand caster kit
- CHEF-DOOR102** Door kit for stands 6 & 10 levels, includes left door + left side
- CHEF-FLKIT** Floor anchoring kit for stands
- CHEF-ANTISLIP** Anti slip hygienic feet extension 1" (26mm) for countertop installation (set of 4)

### SPECIALTY ITEMS

- CHEF-INSERT102** Mobile rack for GN accessories
- CHEF-INSCART102** Banqueting table for mobile racks
- CHEF-INSERTKIT2** Banqueting / mobile rack run-in rail (includes docking parts for the stand)
- CHEF-PLATE102** Mobile plate racks (~52 plates)
- CHEF-BLANKET102** Blankets for mobile plate racks

As continued product improvement is a policy of Vulcan, specifications are subject to change without notice.

## ACCESSORIES & OPTIONS

### CHEMICALS

- CHEF-TAB** Chef'sCombi Cleaner Tabs (100)
- CHEF-STICK** Chef'sCombi Care Sticks (100)

### WATER FILTRATION

- CB15K-SYSTEM** Hollow Carbon Filter System 15,000 gal. (carbon only treatment)
- CB30K-SYSTEM** Hollow Carbon Filter System 30,000 gal. (carbon only treatment)
- SMF600-SYSTEM** ScaleBlocker® (carbon with scale inhibitor) water filtration system
- SMF620-SYSTEM** ScaleBlocker® (carbon with scale inhibitor) water filtration system
- WS40-NOINSTALL** Water Softening (Carbon CBK System required) 40-lb capacity (hard water treatment)
- WS80-NOINSTALL** Water Softening (Carbon CBK System required) 80-lb capacity (hard water treatment)
- HOSEWTR-3/4BBV** Flex stainless steel water connection 72", ¾" GHT-F (female garden hose) on both ends

### MISC

- CHEF-WIFI** Wifi dongle
- CHEF-DLATCH** Double release door latch (field installation)
- CHEF-USBPROBE** USB core probe 3pts - diameter .13" (3.2 mm)
- CHEF-SVPROBE** USB "Sous vide" core probe 1pt diameter .10" (2.5mm)
- 3/4QD-HOSE-4** Gas hose quick connect kit
- CHEF-CVENTKIT** Direct vent kit (electric models only)
- CHEF-DVENT2** Steam deflector
- CHEF-8GUIDE102** Converts 10-level unit into an 8-level unit w/pitch 3.27"

### SERVICE AND INSTALLATION OPTIONS

- Second year extended limited parts and labor warranty
- Site survey
- Installation kits
- Certified Plus Installation (Hobart Service)
- Certified Installation (Hobart Service)
- Water Filtration Installation
- Unit startup